

ABSTRACT

DAVIS, ADAM. Photon Buildup Factors in Laminated Dual-Layer Shields. (Under the direction of Man-Sung Yim.)

In radiation protection, photon buildup factors provide a convenient method for calculating dose and exposure response after various shielding configurations, as well as information about the behavior of radiation in these configurations. Though many situations call for multi-layer shields, few data bases and derived analytical formulas for photon buildup in multi-layer shields exist. This research develops buildup factors and an analytical fit to these for dual-layer shields of various materials. The photon buildup factors were calculated for two-layer shields of various combinations of lead, polyethylene, aluminum and stainless steel for thicknesses of 2-20 mean free paths using the discrete-ordinates code PARTISN. The Gauss-Lobatto S_{100} quadrature was used with a 244-energy-group structure and coupled photon and electron cross sections. These were then benchmarked for representative cases using MCNP5 and fit to a new analytical formula using Mathematica 6.0.

Photon Buildup Factors in Laminated Dual Layer Shields

by

Adam Davis

A thesis submitted to the Graduate Faculty of

North Carolina State University

In partial fulfillment of the

Requirements for the degree of

Master of Science

Nuclear Engineering

Raleigh, NC

11/7/07

Approved by:

Dr. Man-Sung Yim-Committee Chair

Dr Donald J. Dudziak

Dr David N. McNelis

Dr. John Franke

BIOGRAPHY

Born in Raleigh, NC in 1982, Adam Davis received classical acting training at both The Hartt School in West Hartford, CT and the North Carolina School of the Arts in Winston-Salem, NC. Somewhere between tap classes and scene rehearsal, he stumbled upon a calculus book and has not set foot on stage since. After receiving his Bachelor of Science degree in physics from the University of North Carolina Greensboro where he focused on biophysics, he came to the nuclear engineering department at NC State which afforded him the opportunity to complete two summers as a graduate research assistant at Los Alamos National Laboratory out of which this research grew.

ACKNOWLEDGMENTS

I would like to acknowledge Dr. Man-Sung Yim for his patience and continued support over the past two years. His advice and encouragement has been a constant source of inspiration both in this research and in my graduate education. I am also indebted to Dr. David McNelis for his suggestions and help in shaping the course of this research.

Thanks to Dr. H. Omar Wooten for his constant helpfulness, for his immeasurable contributions to this research and for being a good friend during my two summers at LANL. During both summers, the members of AET-2 took me in and treated me more like a colleague than a student and I would like to say thanks especially to Dr. Drew E. Kornreich for his help in providing both advice and the computational resources to complete this project.

A very special thanks go to Dr. Donald J. Dudziak, whose energy, wisdom, insight and humor continue to be a wellspring of inspiration. This research project would not exist without him and his help.

TABLE OF CONTENTS

LIST OF FIGURES	viii
LIST OF TABLES	xiii
1.1 Background	1
1.2 Objective	2
1.3 Slab Geometry	2
CHAPTER 2	4
2.1 Transport Methods	4
2.11 Monte Carlo	4
2.12 Discrete Ordinates	5
2.2 Photon Buildup	5
2.21 Photon Buildup and Response Function Definitions	5
2.22 Materials and Energies	7
2.3 Discrete-Ordinates Calculation Methods	9
2.31 Cross Sections	13
2.32 Cross-Section Libraries	15
2.4 Benchmarking Methods	19
2.41 Group Averaged vs. Continuous Cross Sections	19
2.42 Deep Shield Penetration and Variance Reduction	20
2.5 Fitting Methods	21
2.51 Mathematica	21
2.52 Basis Function	22
2.53 Fit Diagnostics	23
CHAPTER 3	28
3.1 Introduction	28
3.2 Polyethylene and Lead	28
3.21 Incident Photons of Energy 65 keV	30
3.22 Incident Photons of Energy 100 keV	33
3.23 Incident Photons of Energy 500 keV	35
3.24 Incident Photons of Energy 1 MeV	36
3.25 Incident Photons of Energy 2 MeV	37
3.26 Incident Photons of Energy 6 MeV	39
3.27 Incident Photons of Energy 10 MeV	41
3.3 Polyethylene and Stainless Steel	42
3.31 Incident Photons of 65 keV	44
3.32 Incident Photons of 100 keV	46
3.33 Incident Photons of 500 keV	47
3.34 Incident Photons of 1 MeV	48
3.35 Incident Photons of 2 MeV	50
3.36 Incident Photons of 6 MeV	52
3.37 Incident Photons of 10 MeV	53
3.4 Aluminum and Lead	54
3.41 Incident Photons of 65 keV	57
3.42 Incident Photons of 100 keV	58

3.43 Incident Photons of 500 keV	59
3.44 Incident Photons of 1 MeV	60
3.45 Incident Photons of 2 MeV	61
3.46 Incident Photons of 6 MeV	62
3.47 Incident Photons of 10 MeV.....	63
3.5 Aluminum and Stainless Steel.....	64
3.51 Incident Photons of 65 keV	66
3.52 Incident Photons of 100 keV	67
3.53 Incident Photons of 500 keV	68
3.54 Incident Photons of 1 MeV	69
3.55 Incident Photons of 2 MeV	70
3.56 Incident Photons of 6 MeV	71
3.57 Incident Photons of 10 MeV.....	72
3.6 Stainless Steel and Lead.....	73
3.61 Incident Photons of 65 keV	74
3.62 Incident Photons of 100 keV	77
3.63 Incident Photons of 500 keV	78
3.64 Incident Photons of 1 MeV	79
3.65 Incident Photons of 2 MeV	80
3.66 Incident Photons of 6 MeV	81
3.67 Incident Photons of 10 MeV.....	82
CHAPTER 4	84
4.1 Thin Shield Benchmarks.....	84
4.2 Thick Shield Benchmarking.....	89
CHAPTER 5	91
5.1 Comparison with Guvendik	92
5.2 Comparison with Dudziak Weighted-Mean Method.....	93
5.3. Comparison with Multiplicative Formula.....	95
CHAPTER 6	98
APPENDICESAppendix 1: Dose Buildup	102
Appendix 1: Dose Buildup	103
Aluminum followed by lead.....	104
Lead Followed by Aluminum	106
Polyethylene Followed by Lead	108
Lead Followed by Polyethylene (Pb-Poly)	111
Stainless Steel Followed by Lead.....	113
Lead Followed by Stainless Steel (Pb-SS).....	115
Aluminum followed by Stainless Steel (Al-SS).....	118
Stainless Steel Followed by Aluminum (SS-Al).....	120
Polyethylene Followed by Stainless Steel (Poly-SS)	122
Stainless Steel Followed by Polyethylene (SS-Poly)	125
Stainless Steel Followed by Polyethylene (SS-Poly)	125
Appendix 2: Exposure Buildup Factors.....	128
Aluminum Followed by Lead	129
Lead Followed by Aluminum	131

Polyethylene Followed by Lead	133
Lead Followed by Polyethylene (Poly-Pb)	136
Stainless Steel Followed by Lead	138
Lead Followed by Stainless Steel (Pb-SS).....	140
Aluminum followed by Stainless Steel (Al-SS).....	143
Stainless Steel followed by Aluminum (SS-Al).....	145
Polyethylene Followed by Stainless Steel (Poly-SS)	147
Stainless Steel Followed by Polyethylene (SS-Poly)	150
Appendix 3: Number (Flux) Buildup Factors	153
Aluminum followed by Lead (Al-Pb).....	154
Lead followed by Aluminum (Pb-Al).....	156
Polyethylene Followed by Lead	158
Lead Followed by Polyethylene (Poly-Pb).....	161
Stainless Steel Followed by Lead	163
Lead Followed by Stainless Steel (Pb-SS).....	165
Aluminum followed by Stainless Steel (Al-SS).....	168
Stainless Steel followed by Aluminum (SS-Al).....	170
Polyethylene Followed by Stainless Steel (Poly-SS)	172
Stainless Steel Followed by Polyethylene (SS-Poly)	175
Appendix 4: Dose Fit Parameters.....	178
Lead followed by Aluminum	180
Polyethylene followed by lead	181
Lead followed by polyethylene	182
Aluminum followed by Stainless Steel.....	183
Stainless steel followed by aluminum	184
Stainless steel followed by lead.....	185
Lead followed by stainless steel.....	186
Polyethylene followed by stainless steel	187
Stainless steel followed by polyethylene	188
Appendix 5: Exposure Fit Parameters	189
Lead followed by aluminum	191
Polyethylene followed by lead	192
Lead followed by polyethylene	193
Aluminum followed by stainless steel.....	194
Stainless steel followed by aluminum	195
Stainless steel followed by lead.....	196
Lead followed by stainless steel.....	197
Polyethylene followed by stainless steel	198
Stainless steel followed by polyethylene	199
Appendix 6: Dose Fit Percent Differences	200
Aluminum followed by lead.....	201
Lead followed by aluminum	208
Lead Followed by Polyethylene	222
Stainless Steel Followed by Lead.....	229
Lead followed by Stainless Steel.....	236

Aluminum Followed by Stainless Steel.....	243
Stainless Steel followed by Aluminum.....	250
Polyethylene followed by Stainless Steel	257
Appendix 7: Exposure Fit Fractional Differences.....	271
Aluminum followed by lead.....	272
65 keV Al-Pb Exposure (Fractional Difference).....	272
Lead followed by Aluminum.....	279
Polyethylene followed by Lead.....	286
Lead Followed by Polyethylene	293
Stainless Steel Followed by Lead.....	300
Lead Followed by Stainless Steel.....	307
Aluminum Followed by Stainless Steel.....	314
Stainless Steel followed by Aluminum.....	321
Polyethylene Followed by Stainless Steel	328
Stainless Steel Followed by Polyethylene	335
Appendix 8: Dose Fit Diagnostics.....	342
Aluminum followed by lead.....	343
Lead followed by aluminum	344
Polyethylene followed by lead	344
Lead followed by polyethylene	345
Stainless steel followed by lead.....	346
Lead followed by stainless steel.....	347
Aluminum followed by stainless steel.....	347
Stainless steel followed by aluminum	348
Polyethylene followed by stainless steel	349
Stainless steel followed by polyethylene	350
Appendix 9: Exposure Fit Diagnostics.....	351
Aluminum followed by lead.....	352
Lead followed by aluminum	353
Polyethylene followed by lead	353
Lead followed by polyethylene, continued:.....	354
Stainless steel followed by lead.....	355
Lead followed by stainless steel.....	356
Aluminum followed by stainless steel.....	356
Stainless steel followed by aluminum	357
Polyethylene followed by stainless steel	358
Stainless steel followed by polyethylene	359
Appendix 10: Sample NJOY input File for Polyethylene and Stainless Steel	360
Appendix 11: Sample CEPXS Input File	363
Appendix 12: PARTISN Sample input file	359
Appendix 13: Anatomy of PARTISN Input Parameters	363
Appendix 14: Sample MCNP5 input file for 65 keV photons incident on a 2 mfp shield of aluminum followed by lead	366
Appendix 15: Sample MCNP5 input file illustrating the variance reduction technique used for 65 keV photons incident on a 10 mfp shield of aluminum followed by lead.....	369

LIST OF FIGURES

Figure 2.21 Dose buildup as a function of aluminum and lead thickness	9
Figure 2.321 Exposure and dose response functions	17
Figure 2.531 Fractional differences between calculated values and fit using an incorrect basis function.....	26
Figure 2.532 Fractional Difference between Fit and Data for 6-MeV Photons normally incident on shields of polyethylene followed by lead	26
Figure 3.21 Total Mass Interaction coefficients for polyethylene and lead	29
Figure 3.22 Mass Interaction Coefficient (coherent and incoherent scattering) for polyethylene and lead	29
Figure 3.23 Mass Attenuation Coefficient (photoelectric absorption and pair production) for polyethylene and lead	30
Figure 3.211 Dose Buildup Factors for 65 keV photons incident on shields of polyethylene and lead of varying thicknesses. The blue surface is lead followed by polyethylene and the red is polyethylene followed by lead.....	30
Figure 3.212 Exposure Buildup Factors for 65 keV photons incident on shields of polyethylene and lead of varying thicknesses. The blue surface is lead followed by polyethylene and the red is polyethylene followed by lead.....	31
Figure 3.213 Flux Spectrum for 65 keV Photons incident on a 2 mfp of polyethylene followed by 2 mfp of lead.....	32
Figure 3.214 Flux Spectrum for 65 keV Photons incident on a 2 mfp of lead followed by 2 mfp of polyethylene.....	32
Figure 3.221 Dose Buildup Factors for 100 keV photons incident on shields of polyethylene and lead of varying thicknesses. The high buildup factors are due to photons Compton-scattering below lead's K-edge.	33
Figure 3.222 Exposure Buildup Factors for 100 keV photons incident on shields of polyethylene and lead of varying thicknesses. The high buildup factors are due to photons Compton-scattering below lead's K-edge.	34
Figure 3.231 Dose Buildup Factors for 500 keV photons incident on shields of polyethylene and lead of varying thicknesses.	35
Figure 3.232 Exposure Buildup Factors for 500 keV photons incident on shields of polyethylene and lead of varying thicknesses.....	36
Figure 3.241 Dose Buildup Factors for 1 MeV photons incident on shields of polyethylene and lead of varying thicknesses.	36
Figure 3.242 Exposure Buildup Factors for 1 MeV photons incident on shields of polyethylene and lead of varying thicknesses.....	37
Figure 3.251 Dose Buildup Factors for 2 MeV photons incident on shields of polyethylene and lead of varying thicknesses.	38
Figure 3.252 Exposure Buildup Factors for 2 MeV photons incident of shields on polyethylene and lead of varying thicknesses.....	38
Figure 3.261 Dose Buildup Factors for 6 MeV photons incident of shields on polyethylene and lead of varying thicknesses.	40
Figure 3.262 Exposure Buildup Factors for 6 MeV photons incident on shields of polyethylene and lead of varying thicknesses.....	40

Figure 3.271 Dose Buildup Factors for 6 MeV photons incident on shields of polyethylene and lead of varying thicknesses.	41
Figure 3.272 Exposure Buildup Factors for 6 MeV photons incident of shields of polyethylene and lead of varying thicknesses.....	41
Figure 3.31 Total Mass Interaction coefficients for polyethylene and stainless steel.....	43
Figure 3.32 Mass Scattering coefficients for polyethylene and stainless steel.....	43
Figure 3.33 Mass Attenuation coefficients for polyethylene and stainless steel.....	44
Figure 3.311 Dose Buildup Factors for 65 keV photons incident on shields of polyethylene and stainless steel of varying thicknesses.....	45
Figure 3.312 Exposure Buildup Factors for 65 keV photons incident on shields of polyethylene and stainless steel of varying thicknesses.....	46
Figure 3.321 Dose Buildup Factors for 100 keV photons incident of shields of polyethylene and stainless steel of varying thicknesses.....	46
Figure 3.322 Exposure Buildup Factors for 100 keV photons incident on shields of polyethylene and stainless steel of varying thicknesses.....	47
Figure 3.331 Dose Buildup Factors for 500 keV photons incident on shields of polyethylene and stainless steel of varying thicknesses.....	48
Figure 3.332 Exposure Buildup Factors for 500 keV photons incident of shields of polyethylene and stainless steel of varying thicknesses.....	48
Figure 3.341 Dose Buildup Factors for 1 MeV photons incident of shields of polyethylene and stainless steel of varying thicknesses.....	49
Figure 3.342 Exposure Buildup Factors for 1 MeV photons incident of shields of polyethylene and stainless steel of varying thicknesses. The blue surface is stainless steel followed by polyethylene and the red is polyethylene followed by stainless steel.....	50
Figure 3.351 Dose Buildup Factors for 2 MeV photons incident on shields of polyethylene and stainless steel of varying thicknesses.....	51
Figure 3.352 Exposure Buildup Factors for 2 MeV photons incident on shields of polyethylene and stainless steel of varying thicknesses.....	51
Figure 3.361 Dose Buildup Factors for 6 MeV photons incident on shields of polyethylene and stainless steel of varying thicknesses.....	52
Figure 3.362 Exposure Buildup Factors for 6 MeV photons incident on shields of polyethylene and stainless steel of varying thicknesses.....	53
Figure 3.371 Dose Buildup Factors for 10 MeV photons incident on shields of polyethylene and stainless steel of varying thicknesses.....	54
Figure 3.372 Exposure Buildup Factors for 10 MeV photons incident on shields of polyethylene and stainless steel of varying thicknesses.....	54
Figure 3.41 total Mass Interaction coefficients aluminum and lead	55
Figure 3.42 Total Mass Scattering coefficients for aluminum and lead	56
Figure 3.43 Total Mass Absorption coefficients for aluminum and lead.....	56
Figure 3. 411 Dose Buildup Factors for 65 keV photons incident on shields of lead and aluminum of varying thicknesses.....	57
Figure 3. 412 Exposure Buildup Factors for 65 keV photons incident on shields of lead and aluminum of varying thicknesses.....	57
Figure 3.421 Dose Buildup Factors for 100 keV photons incident on shields of lead and aluminum of varying thicknesses.....	58

Figure 3.422 Exposure Buildup Factors for 100 keV photons incident on shields of lead and aluminum of varying thicknesses.....	59
Figure 3. 431 Dose Buildup Factors for 500 keV photons incident on shields of lead and aluminum of varying thicknesses.....	59
Figure 3. 432 Exposure Buildup Factors for 500 keV photons incident on shields of lead and aluminum of varying thicknesses.....	60
Figure 3. 441 Dose Buildup Factors for 1 MeV photons incident on shields of lead and aluminum of varying thicknesses.....	60
Figure 3.442 Exposure Buildup Factors for 1 MeV photons incident on shields of lead and aluminum of varying thicknesses.....	61
Figure 3. 451 Dose Buildup Factors for 2 MeV photons incident on shields of lead and aluminum of varying thicknesses.....	61
Figure 3. 452 Exposure Buildup Factors for 2 MeV photons incident on shields of lead and aluminum of varying thicknesses.....	62
Figure 3.461 Dose Buildup Factors for 6 MeV photons incident on shields of lead and aluminum of varying thicknesses.....	62
Figure 3.462 Exposure Buildup Factors for 6 MeV photons incident on shields of lead and aluminum of varying thicknesses.....	63
Figure 3.471 Dose Buildup Factors for 10 MeV photons incident on shields of lead and aluminum of varying thicknesses.....	63
Figure 3.472 Exposure Buildup Factors for 10 MeV photons incident on shields of lead and aluminum of varying thicknesses.....	64
Figure 3.51 Mass Interaction Coefficient (coherent and incoherent scattering) for polyethylene and lead.....	64
Figure 3.52 Mass Interaction Coefficient (coherent and incoherent scattering) for polyethylene and lead.....	65
Figure 3.53 Mass Interaction Coefficient (coherent and incoherent scattering) for polyethylene and lead.....	65
Figure 3.511 Dose Buildup Factors for 65 keV photons incident on shields of aluminum and stainless steel of varying thicknesses.	66
Figure 3.512 Exposure Buildup Factors for 65 keV photons incident on shields of aluminum and stainless steel of varying thicknesses.....	66
Figure 3.521 Dose Buildup Factors for 100 keV photons incident on shields of aluminum and stainless steel of varying thicknesses.	67
Figure 3.522 Exposure Buildup Factors for 100 keV photons incident on shields of aluminum and stainless steel of varying thicknesses.....	67
Figure 3.531 Dose Buildup Factors for 500 keV photons incident on shields of aluminum and stainless steel of varying thicknesses.	68
Figure 3.532 Exposure Buildup Factors for 500 keV photons incident on shields of aluminum and stainless steel of varying thicknesses.....	68
Figure 3.541 Dose Buildup Factors for 1 MeV photons incident on shields of aluminum and stainless steel of varying thicknesses.	69
Figure 3.542 Exposure Buildup Factors for 1 MeV photons incident on shields of aluminum and stainless steel of varying thicknesses.....	69

Figure 3.551 Dose Buildup Factors for 2 MeV photons incident on shields of aluminum and stainless steel of varying thicknesses.	70
Figure 3.552 Exposure Buildup Factors for 2 MeV photons incident on shields of aluminum and stainless steel of varying thicknesses.	70
Figure 3.561 Dose Buildup Factors for 6 MeV photons incident on shields of aluminum and stainless steel of varying thicknesses.	71
Figure 3.562 Exposure Buildup Factors for 6 MeV photons incident on shields of aluminum and stainless steel of varying thicknesses.	71
Figure 3.571 Dose Buildup Factors for 10 MeV photons incident on shields of aluminum and stainless steel of varying thicknesses.	72
Figure 3.572 Exposure Buildup Factors for 10 MeV photons incident on shields of aluminum and stainless steel of varying thicknesses.	72
Figure 3.61 Mass Scattering Coefficient (coherent and incoherent scattering) for stainless steel and lead.	73
Figure 3.62 Mass Scattering Coefficient (coherent and incoherent scattering) for stainless steel and lead.	73
Figure 3.63 Mass Absorption Coefficient (coherent and incoherent scattering) for stainless steel and lead.	74
Figure 3.611 Dose Buildup Factors for 65 keV photons incident on shields of stainless steel and lead of varying thicknesses.	74
Figure 3.612 Exposure Buildup Factors for 65 keV photons incident on shields of stainless steel and lead of varying thicknesses.	75
Figure 3.613 Flux Spectrum for 65 keV photons incident on 2 mfp of stainless steel followed by lead.	76
Figure 3.614 Flux Spectrum for 65 keV photons incident on 2 mfp lead followed by stainless steel.	76
Figure 3.621 Dose Buildup Factors for 100 keV photons incident on shields of stainless steel and lead of varying thicknesses.	77
Figure 3.622 Exposure Buildup Factors for 100 keV photons incident on shields of stainless steel and lead of varying thicknesses.	78
Figure 3.631 Dose Buildup Factors for 500 keV photons incident on shields of stainless steel and lead of varying thicknesses.	78
Figure 3.632 Exposure Buildup Factors for 500 keV photons incident on shields of stainless steel and lead of varying thicknesses.	79
Figure 3.641 Dose Buildup Factors for 1 MeV photons incident on shields of stainless steel and lead of varying thicknesses.	79
Figure 3.642 Exposure Buildup Factors for 1 MeV photons incident on shields of stainless steel and lead.	80
Figure 3.651 Dose Buildup Factors for 2 MeV photons incident on shields of stainless steel and lead of varying thicknesses.	80
Figure 3.652 Exposure Buildup Factors for 2 MeV photons incident on shields of stainless steel and lead of varying thicknesses.	81
Figure 3.661 Dose Buildup Factors for 6 MeV photons incident on shields of stainless steel and lead of varying thicknesses.	81

Figure 3.662 Exposure Buildup Factors for 6 MeV photons incident on shields of stainless steel and lead of varying thicknesses.	82
Figure 3.671 Dose Buildup Factors for 10 MeV photons incident on shields of stainless steel and lead of varying thicknesses.	82
Figure 3.672 Exposure Buildup Factors for 10 MeV photons incident on shields of stainless steel and lead of varying thicknesses.	83
Figure 4.11 Absolute fractional differences between PARTISN flux calculations and MCNP5 Flux Calculations.	85
Figure 4.12 PARTISN vs. MCNP5 Fractional Difference for 10 MeV photons incident on a 2-mfp shield of lead followed by stainless steel.	88
Figure 4.13 MCNP5 Relative Standard Deviation for Dose calculation of 10 MeV Photons incident on a 2mfp shield of lead followed by stainless steel.	88
Figure 5.11 Plot of Guvendik formula (blue surface) for dose buildup at 1 MeV for water followed by lead vs. Davis formula (red surface) for dose buildup at 1 MeV for polyethylene followed by lead.	92
Figure 5.12 Plot of Guvendik formula (blue surface) for dose buildup at 1 MeV for water followed by iron vs. Davis formula (red surface) for dose buildup at 1 MeV for polyethylene followed by iron.	93
Figure 5.21 Plot of fractional difference between Dose Buildup Data for 1 MeV and the Dudziak weighted mean formula (blue surface) vs. the same for the present fit formula (red surface) for dose buildup for stainless steel followed by lead at 1 MeV. The Single-layer Buildup factors used in the Dudziak weighted mean formula were from Schirmers [15].	94
Figure 5.22 Plot of fractional difference between dose buildup data for 1 MeV and the Dudziak weighted mean formula (blue surface) vs. the same for the present fit formula (red surface) for dose buildup for lead followed by stainless steel at 1 MeV.	95
Figure 5.31 Plot of fractional difference between Dose Buildup Data and the multiplicative formula (blue surface) vs. the same for the present formula (red surface) for dose buildup for stainless steel Followed by lead. The Single-layer Buildup factors used in the multiplicative formula were from Schirmers [15].	96
Figure 5.32 Plot of fractional difference between Dose Buildup Data and the multiplicative formula (blue surface) vs. the same for the present formula (red surface) for dose buildup for lead followed by stainless steel. The single-layer buildup factors used in the multiplicative formula were from Schirmers [15].	96

LIST OF TABLES

Table 2.221 Energies used, the rationale for their use, and some possible sources [21].	7
Table 2.222 Shield Configurations.	7
Table 2.223 Material compositions	8
Table 2.224 Summary of shielding materials	8
Table 2.31 Gauss-Lobatto S_{100} quadrature details	10
Table 2.32 244-group structure	11
Table 2.321 Relevant user defined options for PARTISN and their values	19
Table 4.11 Fractional Difference Between PARTISN and MCNP5 Flux Calculations	85
Table 4.12 Fractional Difference Between PARTISN and MCNP5 Dose Calculations	86
Table 4.13 Fractional Difference Between PARTISN and MCNP5 Exposure Calculations	86
Table 4.21 Benchmark values for representative thick shields	90

CHAPTER 1 Introduction

1.1 Background

Gladys White observed in 1950 that for a 4.75 Ci gamma source in a sphere of water, the dosage decreased with the distance less rapidly than a law of the form $\exp(-\mu_0 r)/r^2$, owing to the building up of secondary scattered radiation. [1] Thus, White defined the *buildup factor* as the ratio of the observed ionization to the ionization expected from the primary gamma rays only, disregarding multiple scattering. In 1954, the first comprehensive sets of photon buildup factors were developed and reported in Goldstein and Wilkins' landmark 1954 Paper for point, isotropic and monoenergetic gamma sources in infinite homogeneous media [2]. These buildup factors, along with others [2-3], were based on moments method calculations and only accounted for Compton (incoherent) scattering [4]. As transport codes became more sophisticated and computational power increased, it became possible to develop buildup factors which also take secondary photons from coherent scattering, pair production and photo-electric absorption into account. As buildup factors came into wider usage, several approximations were developed [4] for homogeneous materials of varying thickness. The most successful of these approximations has been the geometric progression approximation [5]. Despite the accuracy with which buildup factors for homogeneous shields have been developed, precise treatments for heterogeneous shields are rare and such data for non-spherical geometry is virtually nonexistent. Most early attempts to develop buildup factors for stratified shields consisted of combining buildup factors calculated for homogeneous shields to approximate experimental data [6-9]. More recent attempts have

used transport codes to generate response data for stratified shields which is then used to develop buildup factors. [10]

1.2 Objective

In radiation protection, photon buildup factors provide a convenient method for calculating dose and exposure response after various shielding configurations, as well as information about the behavior of radiation in these configurations. Though many situations call for multi-layer shields, few data bases and derived analytical formulas for photon buildup in multi-layer shields exist. This research develops buildup factors and an analytical fit to these for dual-layer shields of various materials.

The photon buildup factors were calculated for two-layer shields of various combinations of lead, polyethylene, aluminum and stainless steel for thicknesses of 2-20 mean free paths using the discrete-ordinates code PARTISN. The Gauss-Lobatto S_{100} quadrature was used with a 244-energy-group structure and coupled photon and electron cross sections. These were then benchmarked using MCNP5 and fit using Mathematica 6.0.

1.3 Slab Geometry

Most buildup factor data for stratified shields is in spherical geometry. There are many practical cases in which spherical geometry is inappropriate. Gloveboxes, such as those in the transuranic handling facilities at Los Alamos National Laboratory (LANL), have slab-geometric shielding. Thus, in modeling these facilities, engineers must rely on approximate “recipes” for buildup factors if they wish to quickly calculate any type of response.

Pandemonium is a tool designed at LANL for this purpose. With a lack of slab-geometric multi-layer buildup factors, it relies on the following recipe [12]:

$$B_{tot} = B_1(b_1) \times B_2(b_2) \quad (1.21)$$

Where

B_i = Buildup Factor for material n

b_i = optical thickness of material n

Despite the popularity of this expression, this is, at best, a marginal approximation.

CHAPTER 2

Photon Buildup Factors

2.1 Transport Methods

Transport theory is the mathematical description of the transport of particles through some host medium [13]. Most transport calculations are computational solutions of the Boltzmann transport equation, so called because of its similarity to an equation derived by Ludwig Boltzmann in relation to the kinetic theory of gases [14] in which the transported particles are indistinguishable from the host medium.

The two types of transport calculations used in this research are the Discrete-Ordinates Method and the Monte Carlo Method.

2.1.1 Monte Carlo

The Monte Carlo method does not explicitly solve the Boltzmann equation. It is a stochastic, numerical technique that exploits the fact that macroscopic cross sections may be interpreted as a probability of interaction per unit distance traveled by a particle. A set of particle histories is generated by following individual particles through successive collisions. These collisions and their results are determined from the range of possibilities by sets of random numbers. Thus, greater statistical accuracy comes at computational expense, making the Monte Carlo method less desirable for production calculations involving thick shields. Thus, the Monte Carlo method was better suited as a benchmarking tool for this research. Given the energy range of interest, the Monte Carlo Neutral Particle code (MCNP5) was used. The cross-section library used was the mcplib04 which is consistent with the cross

section library used in the discrete ordinates calculations.

2.12 Discrete Ordinates

The distinguishing characteristic of the discrete-ordinates (or S_n) method is the discretization of the angular variable, called the quadrature. This allows the angular integrals in the equation to be approximated by sums and the angular derivatives to be approximated by differences [14]. The method is in other respects similar to the spherical harmonics method in that the energy spectrum is treated by a multi-group approximation (allowing for the use of group averaged cross-sections as opposed to the continuous cross-sections used in the Monte-Carlo method) and a discrete mesh is used for the spatial coordinates. For this research, the discrete-ordinates code Parallel Time Independent S_n (PARTISN) was used with a 244-group energy structure developed by Schirmers [15] and the Gauss-Lobatto S_{100} quadrature formula, which, unlike most quadrature formulae, includes the normal directions ($\mu=1$, and $\mu=-1$). This quadrature set is consistent with previous work on slab-geometric buildup factors, and given that this research deals exclusively with photons of normal incidence, a quadrature set that includes the normal directions is necessary.

The cross-section library used was generated in NJOY and formatted for PARTISN by a version of CEPXS modified to read NJOY output.

2.2 Photon Buildup

2.21 Photon Buildup and Response Function Definitions

The photon build-up factor, B , is defined as the ratio of the total photon flux (or response to the total flux) to the uncollided photon flux (or response to the uncollided flux) after transmission through a slab of a given optical thickness of b *mean free paths*:

$$B_b = \frac{\int R_b(E)\phi(E)dE}{R_b(E_0)\phi_0(E_0)} \quad (2.211)$$

where:

$R_b(E)$ = Response function for response x (flux, dose, exposure, etc)

$\phi(E)$ = total flux spectrum

$\phi_0(E_0)$ = uncollided flux at initial energy E_0

For consistency this research uses the same response functions as Schirmers [15]. These are defined below:

The air exposure response function is given by:

$$R_{\text{exp}} = C \cdot E \cdot \left(\frac{\mu_{\text{en}}(E)}{\rho} \right)_{\text{air}} (R \cdot \text{cm}^2) \quad (2.212)$$

where:

$\frac{\mu_{\text{en}}(E)}{\rho}$ = mass energy absorption coefficient for air (cm^2/g)

E = photon energy (MeV)

C = 1.835×10^{-8} (R-g/MeV)

The ambient dose equivalent (henceforth “dose”) response function is given by:

$$R_{\text{dose}} = H^*(10)(E) (\text{pSv-cm}^2) \quad (2.213)$$

where

$H^*(10)(E)$ = dose coefficient at a 10-mm depth in the tissue spherical phantom (pSv-cm^2)

2.22 Materials and Energies

The order of materials with varying atomic number (Z) affects the photon buildup in a two-layer shield. This is shown by data calculated using PARTISN for seven representative energies:

Table 2.221 Energies used in the discrete-ordinates calculations, the rationale for their use, and some possible sources [21].

Energies	Reason for Energy Selection	Possible Sources
65 keV	Below k-edge for lead	Mo-107, Pu-239, Am-241
100 keV	Slightly Above k-edge for lead	U-235, Pu-239, Am-241
500 keV	Common energy of interest	U-235, Pu-239, Am-241
1 MeV	Slightly Below Pair Production Threshold	Am-237, Pu-233, Pu-245
2 MeV	Above Pair Production Threshold	Te-131m, Ir-183
6 MeV	Pair Production Dominates	N-16, B-14, Be-11
10 MeV	Used in PANDEMONIUM	Al-24, Na-24

and six two-layer configurations of materials with varying atomic number:

Table 2.222 Shield Configurations

Z-Configuration	Materials
Low/High	Polyethylene/Lead
High/Low	Lead/Polyethylene
Low/High-Intermediate	Polyethylene/Stainless Steel
High-Intermediate/Low	Stainless Steel/Polyethylene
Low-Intermediate/High-Intermediate	Aluminum/Stainless Steel
High-Intermediate/Low-Intermediate	Stainless Steel/Aluminum
High-Intermediate/High	Stainless Steel/Lead
High/High-Intermediate	Lead/Stainless Steel
Low-Intermediate/High	Aluminum/Lead
High/Low-Intermediate	Lead/Aluminum

Low/Low intermediate shields (i.e. polyethylene/aluminum) are of little practical interest, so they were omitted from this research.

The following Tables present the densities and the material compositions of the materials used:

Table 2.223 Material compositions used in this research. The weight fractions agree with those in Schirmers [15]

Material	Element	Density (g/cm ³)	Weight Fraction
Polyethylene		0.93	1
	<i>Hydrogen</i>		0.143716
	<i>Carbon</i>		0.856284
Aluminum		2.7	1
Stainless Steel		8.03	
	<i>Carbon</i>		0.000136
	<i>Silicon</i>		0.0108
	<i>Phosphorous</i>		0.00007
	<i>Sulfur</i>		0.000078
	<i>Vanadium</i>		0.00041
	<i>Chromium</i>		0.1846
	<i>Manganese</i>		0.00085
	<i>Iron</i>		0.701826
	<i>Cobalt</i>		0.0009
	<i>Nickel</i>		0.1
	<i>Copper</i>		0.00029
<i>Molybdenum</i>	0.00004		
Lead		11.35	1

The following table presents the rationale for the selection of each material:

Table 2.224 Summary of shielding materials used in this research and the rationale for their use.

Material	Rationale
Polyethylene	Low-Z material, good neutron attenuation, more practical than water for many shielding purposes
Aluminum	Low-intermediate-Z material
Stainless Steel	High Intermediate, reasonable photon attenuation
Lead	High-Z material, good photon attenuation, interesting phenomena due to photo-electric effect.

Thicknesses of the shields ranged from 2 to 20 mean free paths. For each configuration, 100 calculations were made so that the result was a 10 x 10 matrix of responses. To illustrate, below is a plot of this matrix for 1-MeV photons incident on an aluminum and lead shield:

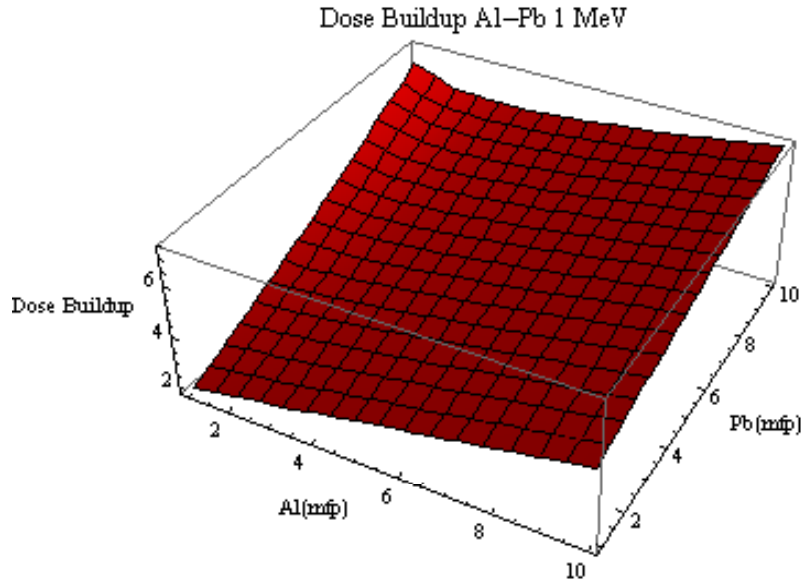

Figure 2.21 Dose buildup as a function of aluminum and lead thickness

2.3 Discrete-Ordinates Calculation Methods

The basis of discrete-ordinates calculations lies in the energy group structure, the quadrature details and the Legendre scattering order. The S_{100} Gauss-Lobatto quadrature set was chosen due to its inclusion of the normal angles ($\mu = 1$ and $\mu = -1$) and is consistent with that calculated by Wooten [16] and is reproduced from that document below. The quadrature details are given in table 2.31. It is important to remember that S_{100} includes the 50 quadratures listed and their negative values. Thus, it is only necessary to list 50 values for S_{100} .

Table 2.31 Gauss-Lobatto S_{100} quadrature details

n	quadrature	weight	n	quadrature	weight
1	1	0.00010101	26	0.69871161	0.011294837
2	0.999258578	0.000622538	27	0.675777444	0.011637424
3	0.997515249	0.00112054	28	0.652169649	0.01196841
4	0.994777307	0.001617163	29	0.627911756	0.012287467
5	0.991047694	0.002112138	30	0.603027948	0.012594275
6	0.986330164	0.002604999	31	0.577543028	0.012888528
7	0.980629431	0.00309526	32	0.5514824	0.013169934
8	0.973951181	0.003582435	33	0.524872043	0.013438212
9	0.966302073	0.004066037	34	0.497738482	0.013693095
10	0.957689734	0.004545587	35	0.470108764	0.013934328
11	0.948122747	0.005020605	36	0.442010432	0.01416167
12	0.937610651	0.005490618	37	0.413471494	0.014374897
13	0.926163923	0.005955158	38	0.384520399	0.014573793
14	0.913793975	0.006413762	39	0.355186006	0.014758163
15	0.900513137	0.006865973	40	0.325497555	0.014927821
16	0.886334648	0.007311339	41	0.295484642	0.015082599
17	0.871272641	0.007749417	42	0.265177182	0.015222342
18	0.85534213	0.00817977	43	0.234605389	0.015346911
19	0.838558996	0.00860197	44	0.203799736	0.015456183
20	0.820939968	0.009015595	45	0.17279093	0.015550047
21	0.802502609	0.009420233	46	0.141609883	0.01562841
22	0.783265298	0.00981548	47	0.110287676	0.015691195
23	0.763247211	0.010200944	48	0.078855532	0.015738338
24	0.742468302	0.010576239	49	0.047344783	0.015769793
25	0.720949285	0.010940991	50	0.01578684	0.015785528

This research uses the 244-energy group structure developed by Schirmers [15] shown in

Table 2.4.

Table 2.32 244-group structure for discrete-ordinates photon buildup calculations which includes the group index number, the energy of the group's upper limit, and the group width in keV.

Group	E (keV)	ΔE (keV)	Group	E (keV)	ΔE (keV)	Group	E (keV)	ΔE (keV)
1	10001	1	42	2001	1	83	385	15
2	10000	500	43	2000	125	84	370	10
3	9500	500	44	1875	125	85	360	10
4	9000	500	45	1750	90	86	350	12.5
5	8500	499	46	1660	60	87	337.5	12.5
6	8001	1	47	1600	99	88	325	12.5
7	8000	250	48	1501	1	89	312.5	11.5
8	7750	250	49	1500	100	90	301	1
9	7500	250	50	1400	65	91	300	15
10	7250	250	51	1335	5	92	285	10
11	7000	250	52	1330	230	93	275	15
12	6750	250	53	1100	99	94	260	10
13	6500	250	54	1001	1	95	250	25
14	6250	249	55	1000	50	96	225	24
15	6001	1	56	950	50	97	201	1
16	6000	250	57	900	50	98	200	5
17	5750	250	58	850	25	99	195	5
18	5500	100	59	825	24	100	190	5
19	5400	200	60	801	1	101	185	5
20	5200	199	61	800	20	102	180	5
21	5001	1	62	780	30	103	175	2.5
22	5000	300	63	750	15	104	172.5	2.5
23	4700	200	64	735	15	105	170	5
24	4500	100	65	720	20	106	165	2.5
25	4400	200	66	700	10	107	162.5	5.5
26	4200	199	67	690	10	108	157	1
27	4001	1	68	680	15	109	156	5
28	4000	100	69	665	30	110	151	1
29	3900	100	70	635	15	111	150	5
30	3800	150	71	620	19	112	145	5
31	3650	150	72	601	1	113	140	2.5
32	3500	167	73	600	2.5	114	137.5	2.5
33	3333	167	74	597.5	2.5	115	135	5
34	3166	165	75	595	20	116	130	5
35	3001	1	76	575	25	117	125	24
36	3000	167	77	550	49	118	101	1
37	2833	167	78	501	1	119	100	1
38	2666	166	79	500	50	120	99	1
39	2500	167	80	450	49	121	98	1
40	2333	167	81	401	1	122	97	1
41	2166	165	82	400	15	123	96	1

Table 2.32 continued

Group	E (keV)	ΔE (keV)	Group	E (keV)	ΔE (keV)	Group	E (keV)	ΔE (keV)
124	95	1	165	41.25	0.25	206	28.2	0.2
125	94	1	166	41	0.5	207	28	0.4
126	93	1	167	40.5	0.4	208	27.6	0.35
127	92	1	168	40.1	0.1	209	27.25	0.25
128	91	1	169	40	0.25	210	27	0.75
129	90	2	170	39.75	0.25	211	26.25	0.736
130	88	2	171	39.5	0.25	212	25.514	1.764
131	86	2.898	172	39.25	0.25	213	23.75	1.25
132	83.102	2.378	173	39	0.25	214	22.5	1.25
133	80.724	0.624	174	38.75	0.25	215	21.25	1.15
134	80.1	0.1	175	38.5	0.25	216	20.1	0.1
135	80	2.5	176	38.25	0.25	217	20	1.03
136	77.5	1.389	177	38	0.25	218	18.97	1.04
137	76.111	6.586	178	37.75	0.25	219	17.93	1.03
138	69.525	4.525	179	37.5	0.25	220	16.9	1.04
139	65	4.9	180	37.25	0.25	221	15.86	0.66
140	60.1	0.1	181	37	0.25	222	15.2	0.1
141	60	2.5	182	36.75	0.25	223	15.1	0.1
142	57.5	2.5	183	36.5	0.25	224	15	0.161
143	55	1.5	184	36.25	0.266	225	14.839	0.487
144	53.5	1	185	35.984	0.434	226	14.352	0.473
145	52.5	1.5	186	35.55	0.55	227	13.879	0.461
146	51	0.9	187	35	0.25	228	13.418	0.378
147	50.1	0.1	188	34.75	0.25	229	13.04	0.216
148	50	1.5	189	34.5	0.5	230	12.824	0.541
149	48.5	1	190	34	0.5	231	12.283	0.184
150	47.5	1.5	191	33.5	0.331	232	12.099	0.189
151	46	1	192	33.169	0.669	233	11.91	0.347
152	45	0.75	193	32.5	0.5	234	11.563	0.348
153	44.25	0.25	194	32	0.5	235	11.215	0.455
154	44	0.3	195	31.5	0.5	236	10.76	0.393
155	43.7	0.2	196	31	0.5	237	10.367	0.267
156	43.5	0.25	197	30.5	0.4	238	10.1	0.1
157	43.25	0.25	198	30.1	0.1	239	10	3.2059
158	43	0.25	199	30	0.25	240	6.7941	1.8753
159	42.75	0.25	200	29.75	0.25	241	4.9188	1.3306
160	42.5	0.25	201	29.5	0.25	242	3.5882	1.032
161	42.25	0.25	202	29.25	0.25	243	2.5562	0.8433
162	42	0.25	203	29	0.3	244	1.7129	1.7129
163	41.75	0.25	204	28.7	0.2			
164	41.5	0.25	205	28.5	0.3			

2.31 Cross Sections

Photon interactions are governed by chance. Thus a photon incident on any material has a finite probability of any of several interactions. Of the four main contributors to photon attenuation in the energy range of 1 keV to 10 MeV, there are two absorption interactions (the photoelectric effect, and pair production) and two scattering interactions {Coherent (Rayleigh) scattering and incoherent (Compton) scattering}.

Photoelectric absorption dominates at low energies. An incident photon interacts with the entire atom and is absorbed. If the energy of the photon is higher than the work function for the material the atom ejects a “photoelectron” usually from the atom’s k shell. Although the difference between the photon energy E and the electron binding energy E_b is distributed between the electron and the recoil atom, the electron receives the bulk of this as kinetic energy due to its relatively small mass. The electron’s kinetic energy is given by:

$$T = h\nu - E_b \quad (2.311)$$

where h is Planck’s constant is the frequency of the incident photon and E_b is the electron binding energy. The ejected electron leaves a vacancy in the atomic electron structure that is filled by an outer electron. Each electronic transition fills a vacancy in the electron structure and is accompanied by the emission of a characteristic fluorescence x-ray or by the ejection of a less tightly bound outer Auger electron.

Incoherent (Compton) scattering is a process of importance in low intermediate energies by which an incident photon of energy E scatters from an interaction with a single electron initially at rest. This interaction results in the transfer of kinetic energy T from the incident photon to an electron that scatters at an angle of θ measured from the initial

direction of the photon. A secondary photon is then emitted with an energy of $E' = E - T$ and moves at angle θ_s . This scattering interaction is depicted in the formula below:

$$E' = \frac{E}{1 + \left(\frac{E}{m_e c^2} \right) (1 - \cos \theta_s)} \quad (2.312)$$

where $m_e c^2$ is the rest energy of the electron.

Unlike Compton scattering, for coherent scattering the incident photon interacts with the collective atomic electrons. Thus, the recoil momentum of the interaction is mostly taken up by the atom, creating only a slight change in photon energy. At low energies (below 50 keV), coherent scattering is the dominant scattering interaction. Around 50 keV, Compton scattering begins to strongly compete and around 100 keV, Compton scattering dominates.

In pair production, an incident photon is completely absorbed and replaced by a positron-electron pair. Given that the rest energies of both electrons and positrons are $m_e c^2 = 0.511$ MeV, pair production requires an incident photon of at least 2×0.511 MeV = 1.022 MeV to create the positron and electron. This is shown in the following equation:

$$T_+ + T_- = E - 2m_e c^2 \quad (2.313)$$

The total atomic pair production cross section varies approximately as Z^2 , and increases logarithmically with photon energy, eventually approaching a constant value at high energies. The positron is quickly annihilated by an electron, after slowing to practically zero kinetic energy. This annihilation process of the positron usually results in the creation of two photons of energy $m_e c^2 = 0.511$ MeV moving in opposite directions [5].

2.32 Cross-Section Libraries

There are numerous cross-section libraries available, but not all of them are for every application. For discrete-ordinates calculations, cross-section databases must have a specific format. For both consistency and because it is the most suitable library for the primary photon transport cross sections in this research, the Evaluated Nuclear Data File (ENDF/B-VI.8) was used. ENDF data can not be directly used in the desired radiation codes, but has to be processed into multi-group and point-wise tables of macroscopic cross-section values sufficient for both Monte Carlo and discrete-ordinates codes by the cross-section processing code NJOY [18].

In order to have the most realistic model possible, electrons were also transported in the calculations. Using the same 244-group structure, CEPXS generated coupled photon-electron cross-section libraries for PARTISN. Thus, treating the problem as a 488-group (244 photons, 244 electrons) one, yields much better results, as it accounts for all electronic interactions such as photoelectric absorption, pair production and fluorescence. It is worth noting the potential dangers of setting up a problem involving multiple particles in PARTISN. The electron and photon groups must be broken up and printed as separate broad groups. Otherwise, PARTISN will simply print fluxes for the sum of all groups (including the electron groups), thus providing non-meaningful results. This effect is dependent on Z-number as materials with higher Z-numbers have more electrons produced so, for instance, the effect is more noticeable in lead than polyethylene.

In order to ensure reliable results, PARTISN requires the user to specify a convergence criterion. This criterion is the maximum difference between calculated response

values after each iteration. For instance, in the 488 group case, the code would iterate itself twice and then compare the data. If, in each group, the difference between the fluxes at each spatial mesh point is smaller than the convergence criteria, the code agrees that the method has converged and that the calculations are correct. The convergence criterion used in this research was 10^{-4} .

The dose response functions for the 244-group structure were tabulated only down to 10 keV, necessitating an extrapolation into the low energies. This was achieved by Schirmers [15] through two processes: by logarithmically interpolating given coefficients at the midpoint of each group and logarithmically extrapolating the coefficients, and through assuming a constant response below the lowest energy for which dose response functions are tabulated. The constant response function was taken as the lowest-energy tabulated value. The exposure response was listed through 1 keV, thus extrapolation was not necessary. Figure 2.2 shows the dose response (along with both extrapolation methods) and the exposure response as a function of Energy [15].

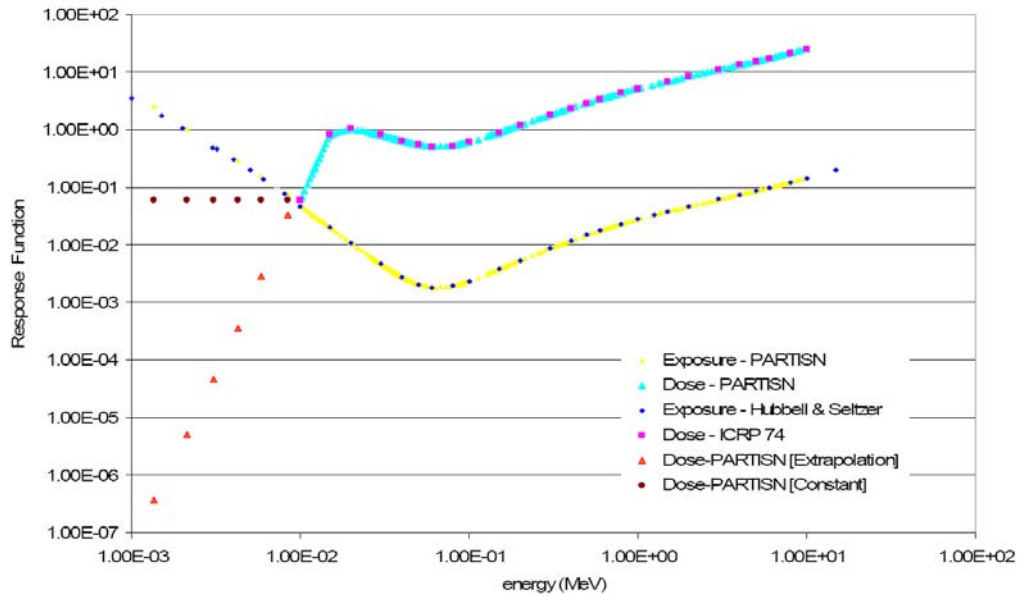

Figure 2.321 Extrapolation and constant scheme for the ICRP dose conversion coefficients (pSv-cm²) and the exposure response function of Berger, Hubbell, and Seltzer (MeV-cm²/g).

Another characteristic of the discrete-ordinates method which further simplifies the transport equation is the discretization of space. Unlike MCNP5, where slab thicknesses are simply input into the code, when setting up a problem in PARTISN, it is necessary for the user to define both coarse and fine spatial meshes and the position of each coarse mesh point is input into the code. For each of these mesh points PARTISN will calculate a solution to the transport equation. The coarse mesh divided the shield into into 1 coarse mesh point per material. The fine mesh divided each coarse mesh point into 100 fine mesh points per mean free path. Thus, for a shield of 20 mfp, PARTISN would calculate the transport at $2 \times 1,000 = 2,000$ mesh points. In specifying a mesh, it is important to note that PARTISN prints the flux at the average thickness of the last two mesh points (i.e., just inside the exit surface of the shield). In MCNP5, however, the flux is tallied (printed) at the exit surface. This must be reconciled in order to have meaningful comparison between the two codes. By adding the

thickness of an extra half of a fine mesh interval to the physical thickness used in PARTISN, the exit flux it prints is at exactly the physical thickness corresponding to the appropriate number of mean free paths.

For a given slab with arbitrary optical thickness, the physical thickness is based on the macroscopic cross section of the material and thus the incident photon energy. Assuming a physical thickness of D corresponding to an optical thickness of b and a fine mesh of order n , the thickness of a fine mesh interval is $\frac{D}{n}$ cm. Because PARTISN prints the flux at the middle of the last fine mesh interval, the physical slab thickness inputted into PARTISN must be increased to a new thickness D' where

$$D' = D \left(1 + \frac{1}{2n} \right) \quad (2.321)$$

This positions the center of the last mesh point at D , thus forcing PARTISN to print the flux at a thickness of exactly D mfp. This is illustrated in the following diagram [15]:

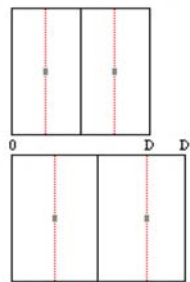

Figure 2.322 Augmentation of the PARTISN slab thickness by half a fine mesh interval to ensure correspondence between physical and optical thickness in flux calculations.

Below is a table summarizing the general details of the PARTISN calculations used in this research.

Table 2.321 Relevant user defined options for PARTISN and their values

PARTISN Details	Option used
Geometry	Infinite Slab
Group Structure	488 Total Groups. 244 Photon Groups, 244 Electron Groups.
Quadrature Set and Order	Gauss-Lobatto, S_{100}
Legendre Scattering Order	P_7
Convergence Criterion	10^{-4}
Coarse Mesh Density	1 per Mean Free Path
Fine Mesh Density	100 per Mean Free Path.

2.4 Benchmarking Methods

Benchmark calculations were performed using the Monte Carlo N-Particle Transport Code (MCNP5). In order to keep computation time to a minimum while still performing a thorough evaluation, the bulk of the benchmark calculations were limited to 2-mfp shields (1 x 1) and 3 energies of incident photons (65 keV, 1 MeV and 10 MeV).

Since MCNP5 is computationally expensive, transport calculations for thick shields require variance reduction techniques to get statistically significant results in a reasonable period of time. Thus, deep-penetration shield calculations were limited to two cases, a 5x5 shield of aluminum followed by lead with 65-keV normally incident photons, and a 10x10 shield of polyethylene followed by lead with 65-keV normally incident photons.

2.41 Group Averaged vs. Continuous Cross Sections

The optical thickness of a shield is determined by its total macroscopic cross section. When comparing Monte-Carlo calculations to Discrete Ordinates, problems arise due to the

varying treatment of the energy variable. Given that the thicknesses used in PARTISN are based on group-averaged cross sections, they will differ from those calculated for a given energy point from the continuous cross sections used in MCNP5. To maintain consistency in the calculations, instead of using a single, discrete source energy in MCNP5, source energies from the appropriate discrete-ordinates energy group were randomly sampled. This technique allowed for the approximation of the group averaging of discrete ordinates in MCNP5, as well as eliminating the need for different physical thicknesses in each code.

2.42 Deep Shield Penetration and Variance Reduction

In order to perform transport calculations for thick shields of 10 and 20 mfp in MCNP5, it becomes of practical necessity to use variance reduction techniques. The easiest of these is to divide the shield into 1-mfp-thick cells and increase the particle importance of each successive cell by an integral factor. MCNP5 prints a warning if the ratio of the importance of successive cells is 4 or greater, thus the importance was increased by a factor of 3 for each adjacent cell. For the 10-mfp (5x5) case, this allowed the code to run two-hundred thousand particles in about 3 minutes, with a relative standard deviation of less than 0.1%. For the 20-mfp (10 x 10) case, the calculation took about 25 minutes (also for two-hundred thousand particles), but still gave a relative standard deviation of less than 1% . In both cases the fractional difference between the MCNP5 and PARTISN calculations was within a few percent. These data are presented in Chapter 4.

2.5 Fitting Methods

Using a single multivariate analytical formula to fit 100 data points of various across such a wide range of values (buildup in this research ranges from around 1 to around 2000) can be difficult. Thus, the data were fit using one of three different methods, or sometimes a combination of methods. Fit diagnostics for all cases are listed in appendices 6-9

First, the buildup data for an entire shield were fit to the formula. This worked fine for most cases. However, photons around 100 keV incident on shields involving lead have a much higher buildup, so the fit was also performed on the logarithm of buildup for these cases. In these cases (which are noted in the appendix) the fit produces the logarithm of the buildup factors. The diagnostics for these cases listed in appendices 6-9 were performed by comparing the anti-log of the formula value to the buildup data.

The third method was to break the data sets into two smaller sets that would be easier to fit. The two sets were referred to as low and high, where “low” refers to a shield of 1-10 mfp of the first material followed by 1-5 mfp of the second material and “high” refers to a shield of 1-10 mfp of the first material followed by 6-10 mfp to the second material.

2.51 Mathematica

Mathematica is a powerful symbolic mathematics software package with superior data handling and modeling capabilities. Its “NonlinearRegress” and “FindFit” functions will use a nonlinear least squares algorithm to fit parameters to a user-defined basis function of n^{th} degree. NonlinearRegress is a routine that calls FindFit to perform the actual fit, and then prints the fit diagnostics.

Though NonlinearRegress provides abundant statistical details about the fit, from a practical standpoint, these are not immediately useful to the engineer. Thus, other diagnostics were made by comparing the fit to the actual data. This is further discussed in Section 2.52 and in Appendices 5 and 6.

2.52 Basis Function

The Basis function supplied to the NonlinearRegress Function in Mathematica was developed primarily by the guess and check method. In the literature, most formulae for buildup factors in multi-layered shields involve some combination of single-layer buildup factors. Guvendik [10] developed analytical fits in 3 independent variables (energy, first material thickness and second material thickness) based on MCNP5 calculations for various materials from 1-10 mfp total optical thickness. In that paper, there are three formulae, a general fit:

$$B(E, x, y) = \frac{a + bE + cx + dy}{1 + fE + gx + hy} \quad (2.521)$$

a fit for shields of a high-Z material followed by a low-Z material:

$$B(E, x, y) = \frac{a + bE + cx + dy}{1 + eE + fE^2 + gx + hEx + kx^2 + ly + mEy + nxy + py^2} \quad (2.522)$$

and a fit for a low-Z material followed by a high-Z Material:

$$B(E, x, y) = \frac{a + bE + cE^2 + dx + eEx + fx^2 + gy + hEy + kxy + ly^2}{1 + mE + nx + py} \quad (2.523)$$

Equations (2.522) and (2.523) are simply reciprocals of each other. It is unclear how these formulae would perform for a shield of a high-intermediate-Z material such as stainless steel followed by a high-Z material such as lead.

After trying many different combinations of rational expressions, with varying degrees of success, the following formula was developed:

$$B(x,y) = \frac{a + bx + cy^2}{f + dx + ex^2 + gy + hy^2} \quad (2.524)$$

where x is the first material optical thickness, y is the second material optical thickness, and a, b, c, d, e, f, g, and h are all parameters.

The Guvendik formulae were developed for, with the exception of lead, completely different materials than were used in this research.

2.53 Fit Diagnostics

In order to develop confidence in the present fit formula, it was useful to determine how sensitive the NonlinearRegress function in Mathematica was to the user supplied basis function. To do so, as seen below, a dummy set of data was generated with an arbitrary function, and then fit, using NonlinearRegress to both this arbitrary basis function and to another arbitrary function that does not resemble the original basis function. Using the Mathematica supplied fit diagnostics; the two fits were then compared.

One set of fit diagnostics provided by the NonlinearRegress option in Mathematica is the analysis of variance table or “ANOVATable”. Below is an example ANOVATable output for an analytical fit of 6-MeV photons incident on shields of polyethylene followed by lead for varying thicknesses:

	DF	SumOfSq	MeanSq
Model	8	6613.58	826.698
Error	92	3.41011	0.0370665
Uncorrected Total	100	6616.99	
Corrected Total	99	1147.83	

According to the Mathematica Documentation,

“...one possible definition of R^2 for a nonlinear regression is the ratio of the difference between the corrected total sum of squares and the residual sum of squares to the corrected total sum of squares.”

In terms of the output from the ANOVATable option, this suggestion would be calculated as

$$\frac{\text{SumOfSquares}_{corrected} - \text{SumOfSquares}_{error}}{\text{SumOfSquares}_{corrected}} \quad (2.531)$$

Thus for the ANOVATable shown above, the R^2 value would be approximately .997. In order to validate this diagnostic, a set of data was generated by a simple multivariate function which was then fit using NonlinearRegress using the original generating function as a basis, and then fit again using another, incorrect basis function and comparing the ANOVATable results.

Using the following function:

$$z = 5x^3 - .25y^3 + x \quad (2.532)$$

This function was used to generate 100 values with x and y both ranging from 1 to 10, resembling the PARTISN data analyzed in this research. A basis function similar to the form of the generator function was supplied to Mathematica:

$$ax^3 - by^3 + x \quad (2.533)$$

This gave the following output:

BestFitParameters → {a → 5. b → -0.25},

ANOVATABLE →

	DF	SumOfSq	MeanSq
Model	4	4.24119×10 ⁸	1.0603×10 ⁸
Error	96	5.12962×10 ⁷	534335.
Uncorrected Total	100	4.75415×10 ⁸	
Corrected Total	99	2.67371×10 ⁸	

From (2.531) the R² value is:

$$\frac{2.67371 \times 10^8 - 1.41507 \times 10^{-23}}{2.67371 \times 10^8} \cong 1 \quad (2.534)$$

Next, a very different basis function of the following form was supplied:

$$z = \frac{a \cdot e^x + b \cdot e^y}{c \cdot x^2 + d \cdot y^2} \quad (2.535)$$

and used to fit the data. The output is as follows:

BestFitParameters → {a → 4.13081, b → -0.00169009, c → 0.157457, d → -0.000751267}

NOVATable®

	DF	SumOfSq	MeanSq
Model	4	4.24119' 10 ⁸	1.0603' 10 ⁸
Error	96	5.12962' 10 ⁷	534335.
Uncorrected Total	100	4.75415' 10 ⁸	
Corrected Total	99	2.67371' 10 ⁸	

Equation (2.531) gives:

$$R^2 = \frac{2.67371 \times 10^8 - 5.12962 \times 10^{-7}}{2.67371 \times 10^8} \cong .81$$

(2.536)

The following plot shows the fractional differences between the generated data and the incorrect fit from basis function (2.535):

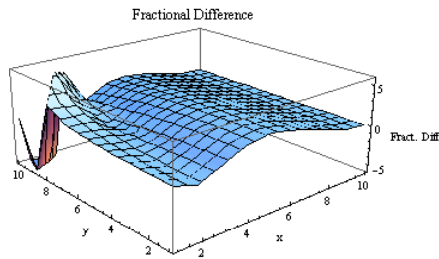

Figure 2.531 Fractional differences between calculated values and fit using an incorrect basis function.

Thus, for a quick evaluation of the fit, the ANOVATable output is a handy tool. More useful fit diagnostics from a practical standpoint are the fractional differences between fit and data as a function of thickness, the maximum and minimum fractional differences and the standard deviation of the fractional differences. Fractional difference is given by:

$$\frac{|B_{Fit} - B_{PARTISN}|}{B_{PARTISN}} \quad (2.537)$$

For the same 6-MeV polyethylene-lead case, the plot of fractional difference as a function of thickness is shown below:

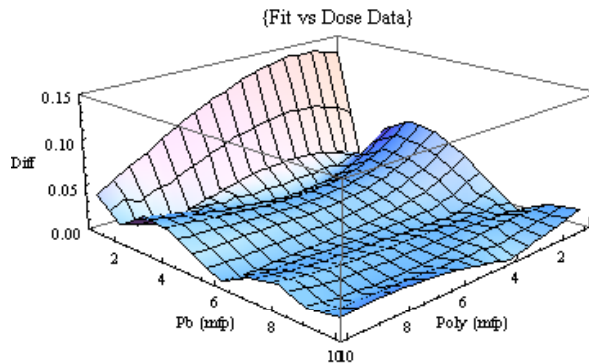

Figure 2.531 Fractional difference between Fit and Data for 6-MeV photons normally incident on shields of polyethylene followed by lead

The fit parameters along with their diagnostic values are listed in Appendices 4-9.

It is important to note that that the fit was performed only for dual-layer shields ranging from thicknesses of 2 mfp (1 mfp of each material) to 20 mfp (10 mfp of each material). It does not predict unity buildup in the absence of shielding and has not been benchmarked for single layer shields.

CHAPTER 3

Dose and Exposure Results

3.1 Introduction

To begin the discussion of results, buildup for the cases of polyethylene followed by lead and the reverse are plotted and discussed in depth. Cases involving lead (or any high Z material) are particularly interesting due to the relatively high energy k-edge as well as the large pair production cross-section in the upper spectrum. Since these characteristics are not as prominent in other materials, the cases involving polyethylene and stainless steel are also discussed in depth.

These two representative cases were chosen because they involve the most dramatic difference in atomic number between the two constituent materials and because all the configurations investigated in this research are similar to one or the other of these cases. For this reason, though surface plots of all cases are presented here, only the two cases mentioned above are discussed in depth.

3.2 Polyethylene and Lead

The following plots of the attenuation coefficients for polyethylene and lead will prove an invaluable tool in the analysis of the results. Several details to notice are the minimum or “trough” between 1 and 6 MeV, and the discontinuous jump in the lead cross section at 88 keV due to the ejection of a photoelectron from the k-shell. This is called the “k-edge”.

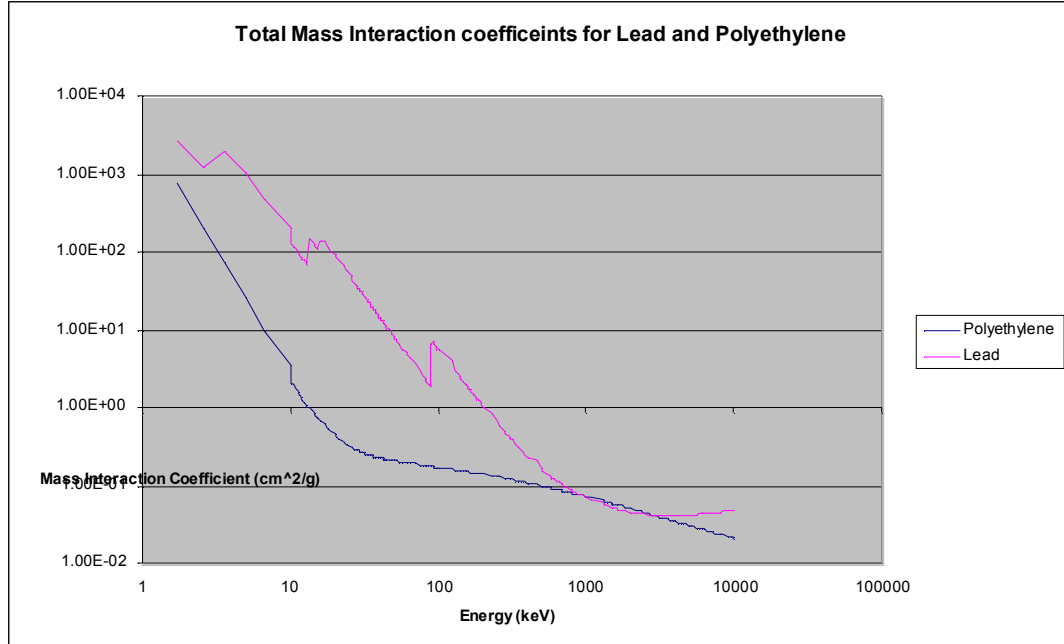

Figure 3.21 Total Mass Interaction coefficients for polyethylene and lead

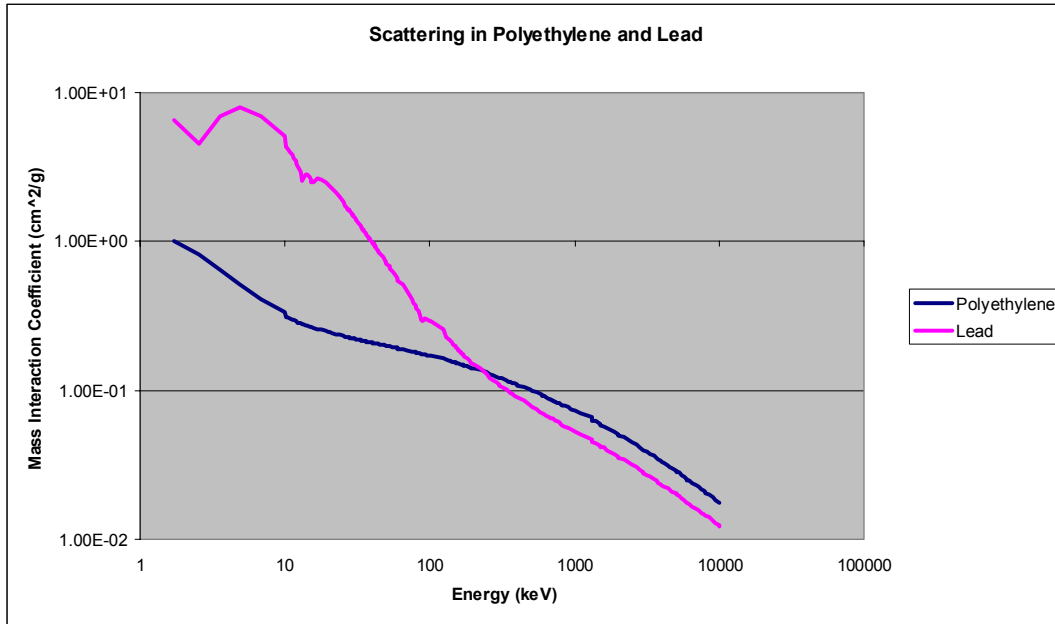

Figure 3.22 Mass Interaction Coefficient (coherent and incoherent scattering) for polyethylene and lead

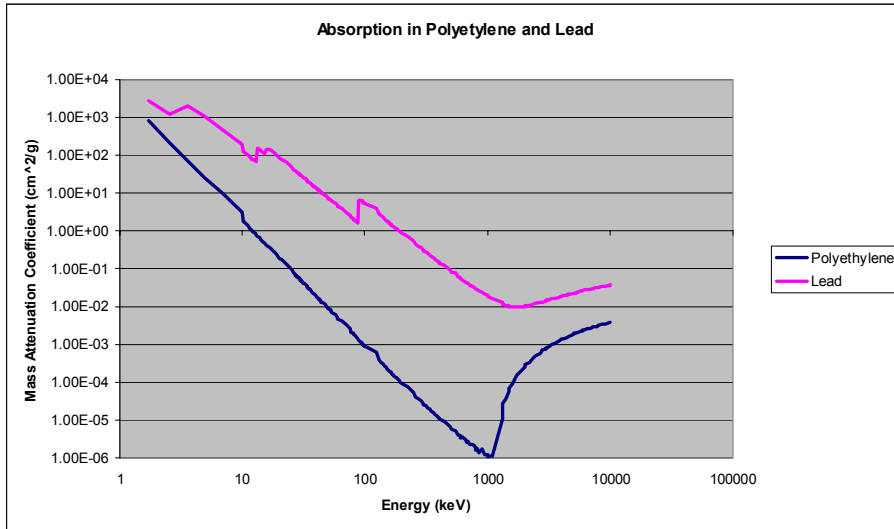

Figure 3.23 Mass Attenuation Coefficient (photoelectric absorption and pair production) for polyethylene and lead

3.21 Incident Photons of Energy 65 keV

In all plots in this section, the red surfaces are plots of dose for shields of polyethylene followed by lead (poly-lead) and the blue surfaces are plots of the reverse cases; lead followed by polyethylene (lead-poly).

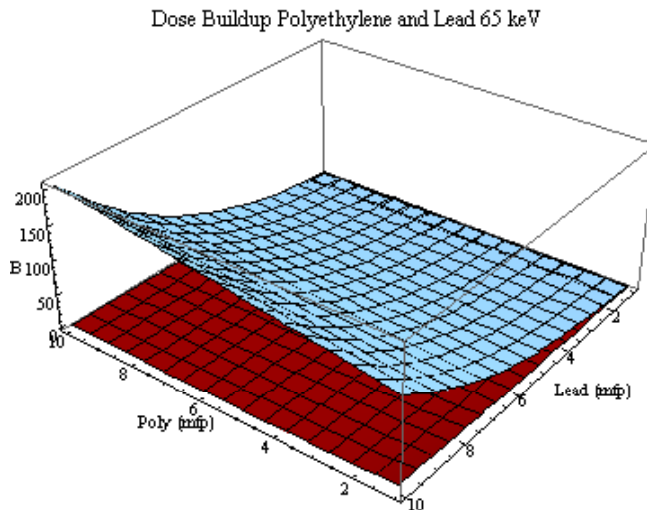

Figure 3.211 Dose Buildup Factors for 65 keV photons incident on shields of polyethylene and lead of varying thicknesses. The blue surface is lead followed by polyethylene and the red is polyethylene followed by lead.

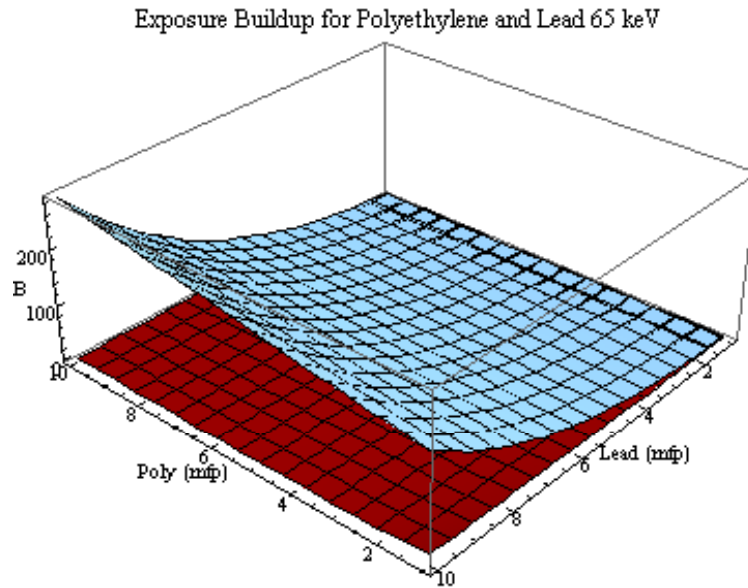

Figure 3.212 Exposure Buildup Factors for 65 keV photons incident of shields on polyethylene and lead of varying thicknesses. The blue surface is lead followed by polyethylene and the red is polyethylene followed by lead.

The buildup factors for the lead-poly shield are much higher than those for the polyethylene-lead shield. This is because when 65 keV photons are incident on a layer of polyethylene, the dominant process is Compton and Rayleigh scattering. Thus, the many photons down-scatter to lower energies but are not absorbed before exiting the layer. When the down-scattered photons exit the polyethylene layer and impinge on the second (lead) layer they are subject to a higher photoelectric absorption cross section and are absorbed. Thus, the exit flux from the lead layer, and hence from the shield, is very low. In the reverse case, the 65 keV source photons incident on the lead layer experience a much lower photoelectric cross section in the lead than any scattered photons. Thus, they have a higher probability of transporting through the entire layer. Since polyethylene has a relatively small absorption cross section, many of the photons that escape the lead will also be completely

transported (though down-scattered) through the polyethylene layer. Thus, the exit flux (and consequently the buildup) will be higher for shields of lead followed by polyethylene than for the reverse case of polyethylene followed by lead. This is evident in the following two tables:

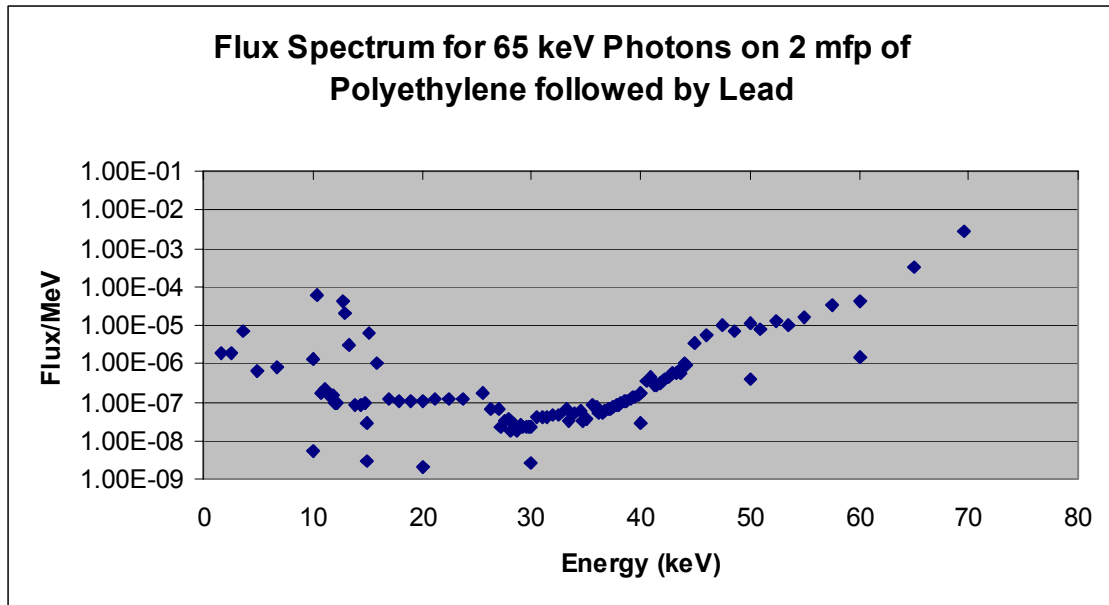

Figure 3.213 Flux Spectrum for 65 keV Photons incident on a shield of 1 mfp of polyethylene followed by 1 mfp of lead.

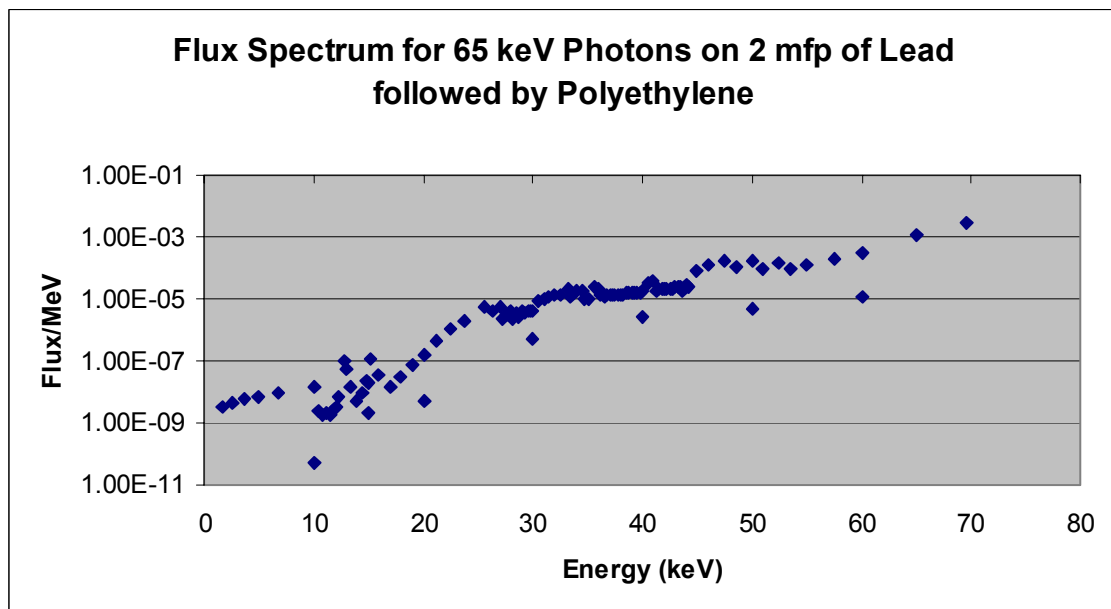

Figure 3.214 Flux Spectrum for 65 keV Photons incident on a shield of 1 mfp of lead followed by 1 mfp of polyethylene.

Recall that, at low energies, the exposure response function increases monotonically while the dose response function increases for an interval before decreasing at the lowest energies. This results in the exposure response being higher for low energy incident photons. From Figures 3.213 and 3.214 it is apparent that there is significant flux in the lower energies to create higher exposure response than dose response.

3.22 Incident Photons of Energy 100 keV

The K-edge for lead occurs at 88 keV. Thus, for shields involving incident photons around this energy many photons will inevitably scatter below the K-edge and experience relatively low absorption. In the following plot of dose buildup for shields of polyethylene and lead with incident photons of 100 keV, the sub-K-edge scattering accounts for the high buildup.

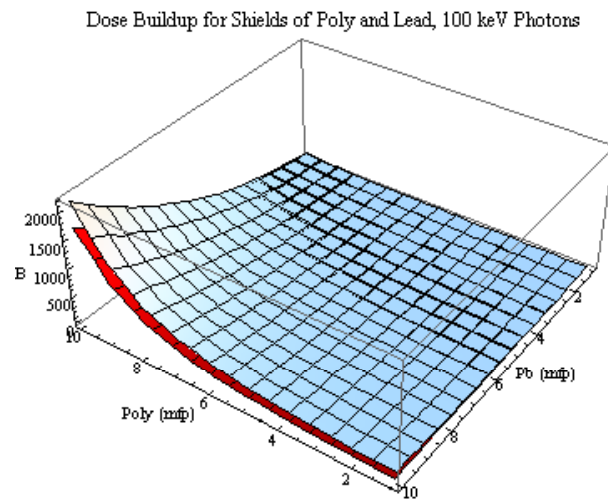

Figure 3.221 Dose Buildup Factors for 100 keV photons incident on shields of polyethylene and lead of varying thicknesses. The high buildup factors are due to photons Compton-scattering below lead's K-edge. The blue surface is lead followed by polyethylene and the red is polyethylene followed by lead.

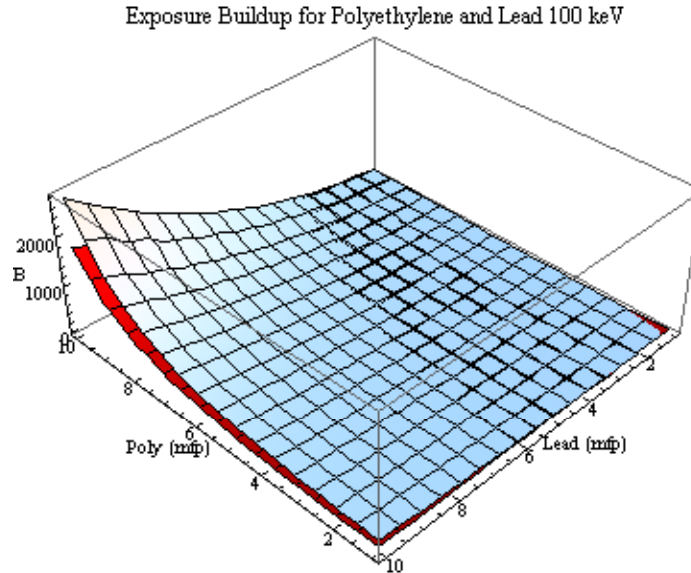

Figure 3.222 Exposure Buildup Factors for 100 keV photons incident on shields of polyethylene and lead of varying thicknesses. The high buildup factors are due to photons Compton-scattering below lead's K-edge. The blue surface is lead followed by polyethylene and the red is polyethylene followed by lead.

Regardless of order, photons slightly above the k-edge incident on shields involving lead will scatter down below 88 keV and experience a discontinuous drop in the photoelectric cross section. The un-scattered photons, however will still experience the higher cross section above 88 keV and thus be much more attenuated. The high buildup is then accounted for by the ratio of a relatively low attenuation of scattered photons to the relatively high attenuation of un-scattered photons.

The order of the materials makes only a relatively slight difference. The shields consisting of a layer of polyethylene followed by lead will have lower buildup factors than the reverse case because of the greater amount of Compton scattering in the polyethylene. In the polyethylene, many photons will Compton-scatter far enough below the k-edge of the lead that they will experience a photoelectric cross section equal to or even greater than that slightly above 88 keV.

In the reverse case, however, only slight Compton scattering occurs in the lead layer relative to photoelectric absorption. Thus, photons are either absorbed above 88 keV or scattered just low enough to experience the lower cross section before escaping to the less attenuating second layer of polyethylene.

3.23 Incident Photons of Energy 500 keV

Around 500 keV, both Compton and coherent scattering are competing strongly in polyethylene and to a lesser degree in lead. In the following plot, the results are similar to those for 65 keV photons. The lead-polyethylene shields have higher buildup factors because the photons incident on lead that are at the source energy will experience a lower attenuation cross section than those that have been down-scattered by a first layer of polyethylene.

Around 500 keV the total cross-section is lower than the discontinuous drop in the k-edge for lead so that effect is not prominent.

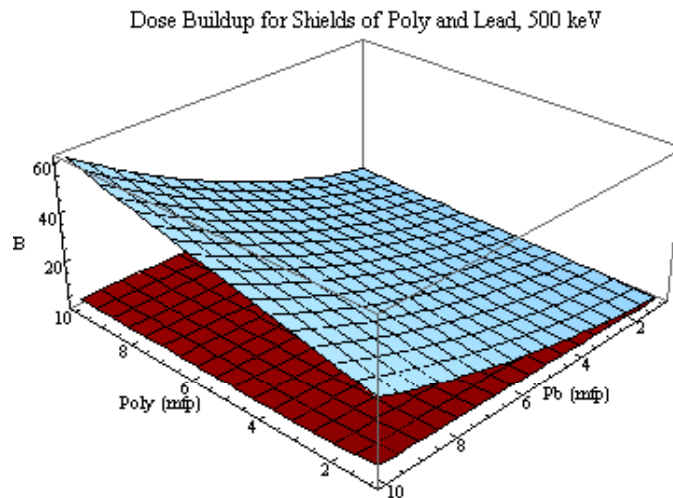

Figure 3.231 Dose Buildup Factors for 500 keV photons incident on shields of polyethylene and lead of varying thicknesses. The blue surface is lead followed by polyethylene and the red is polyethylene followed by lead.

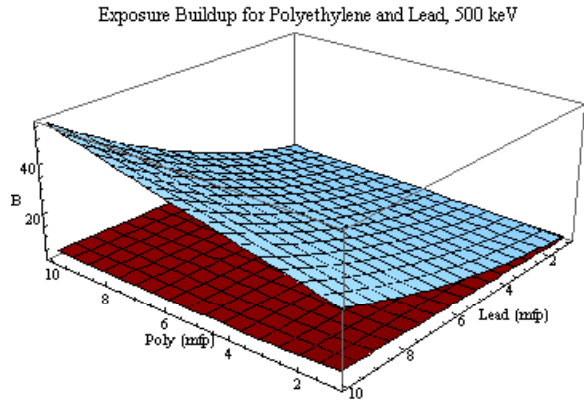

Figure 3.232 Exposure Buildup Factors for 500 keV photons incident on shields of polyethylene and lead of varying thicknesses. The blue surface is lead followed by polyethylene and the red is polyethylene followed by lead.

3.24 Incident Photons of Energy 1 MeV

As mentioned earlier, photons in the energy range of 1 to 6 MeV experience much lower attenuation and scattering cross sections in lead than photons above or below this range (called the “trough.”) This trough effect is especially noticeable in lead, and does not exist below 10 MeV for most lower-Z materials.

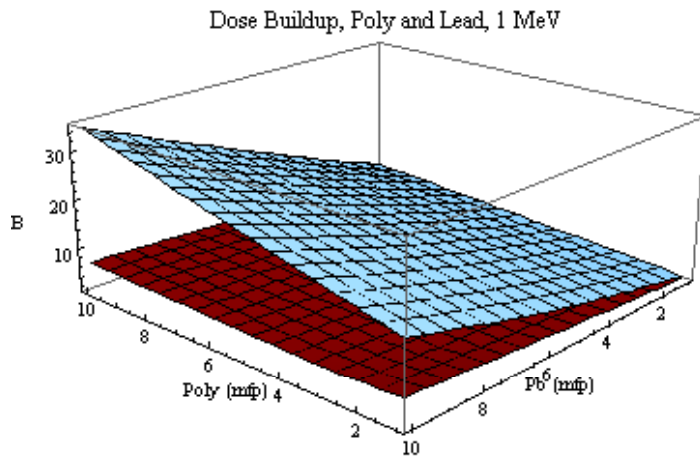

Figure 3.241 Dose Buildup Factors for 1 MeV photons incident on shields of polyethylene and lead of varying thicknesses The blue surface lead followed by polyethylene and the red is polyethylene followed by lead.

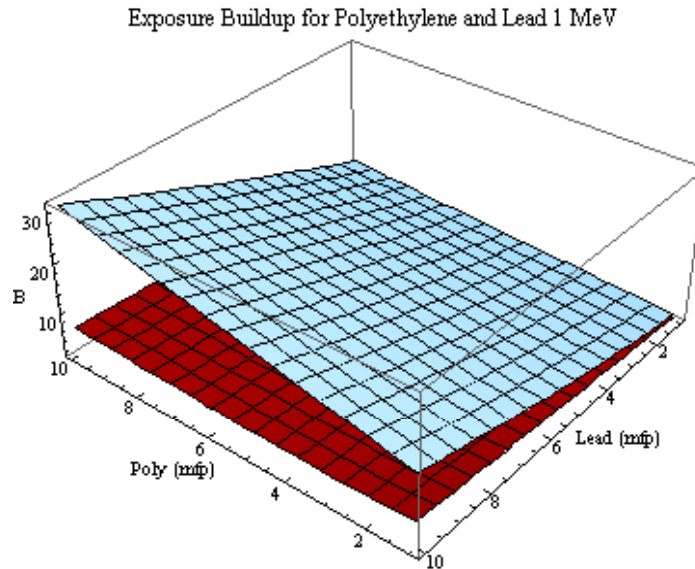

Figure 3.242 Exposure Buildup Factors for 1 MeV photons incident on shields of polyethylene and lead of varying thicknesses The blue surface lead followed by polyethylene and the red is polyethylene followed by lead.

For a shield of lead followed by polyethylene, source-energy photons and Compton scattered photons exiting from the lead will experience a relatively low photoelectric effect in the polyethylene, relative to Compton scattering in the polyethylene. Thus, the Compton scattered photons will contribute significantly to the responses at the exit surface of the polyethylene, leading to high buildup factors.

For the reverse case of polyethylene followed by lead, the photons will be down-scattered by the polyethylene so when they impinge on the second layer (lead) they will experience a much higher attenuation cross section (mostly photoelectric), thus accounting for the lower buildup in this case.

3.25 Incident Photons of Energy 2 MeV

Photons of energies around 2 MeV are more susceptible to the effects of the “trough”.

The lower cross section in this energy range causes an increase in the uncollided response which, in turn decreases the buildup as compared with that from lower energy photons incident on the same shields.

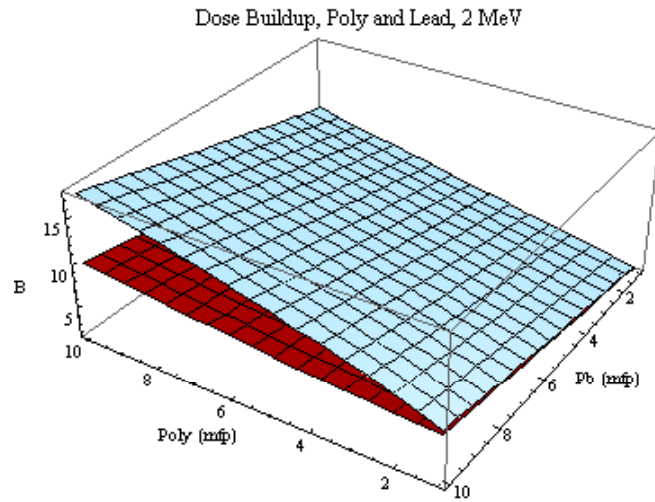

Figure 3.251 Dose Buildup Factors for 2 MeV photons incident on shields of polyethylene and lead of varying thicknesses The blue surface lead followed by polyethylene and the red is polyethylene followed by lead.

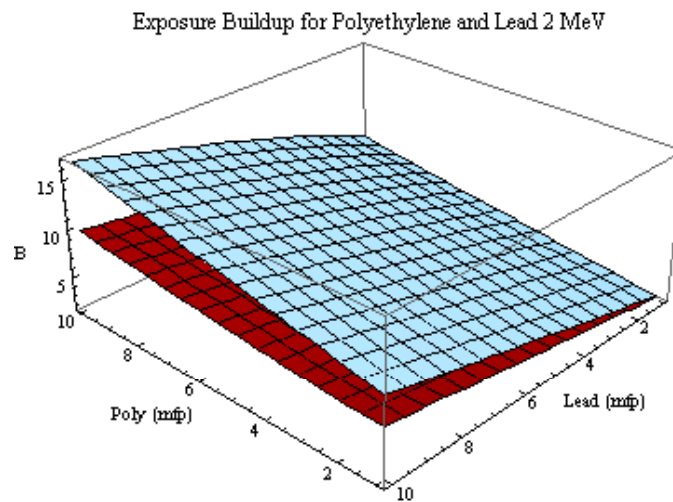

Figure 3.252 Exposure Buildup Factors for 2 MeV photons incident of shields on polyethylene and lead of varying thicknesses The blue surface lead followed by polyethylene and the red is polyethylene followed by lead

Another feature of the 2 MeV results is that the buildup in the shields of polyethylene followed by lead is increasing relative to that in shields of lead followed by polyethylene. This is due partly to the beginning of pair production at 1.022 MeV; an interaction much more prominent in lead than polyethylene. At 2 MeV, shields beginning with polyethylene down-scatter many incident photons below 1.022 MeV. Thus, when they impinge upon the lead, they are able to avoid the effects of pair production.

In the reverse case, the 2 MeV incident photons are immediately subject to absorption by pair production. Pair production is not prominent at this energy so the shields of lead followed by polyethylene still have higher buildup.

3.26 Incident Photons of Energy 6 MeV

For 6 MeV photons incident on shields of polyethylene followed by lead, photons are Compton scattered by the polyethylene into the “trough” where they will experience a lower total absorption cross-section (mainly pair production) in the lead layer. This effect is seen in the following plots.

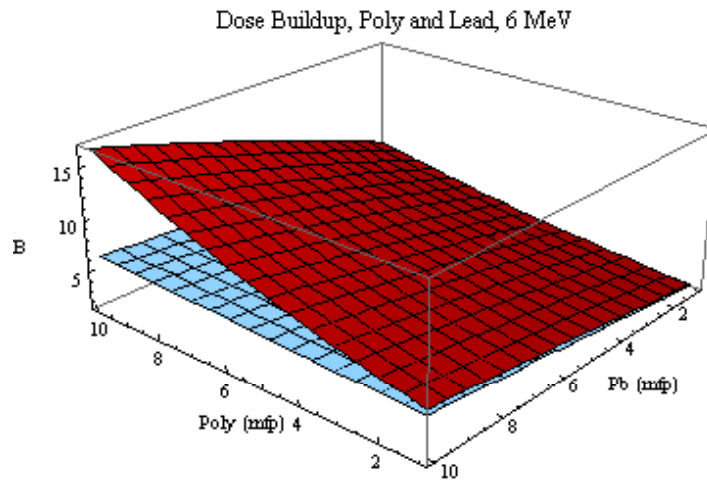

Figure 3.261 Dose Buildup Factors for 6 MeV photons incident on shields of polyethylene and lead of varying thicknesses The blue surface lead followed by polyethylene and the red is polyethylene followed by lead.

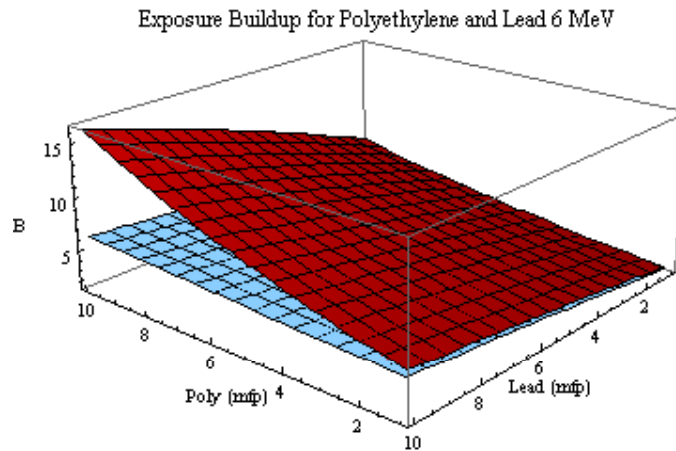

Figure 3.262 Exposure Buildup Factors for 6 MeV photons incident on shields of polyethylene and lead of varying thicknesses The blue surface lead followed by polyethylene and the red is polyethylene followed by lead.

Here, the shields of polyethylene followed by lead have a higher buildup, unlike the cases for lower energies when the shields beginning in lead had higher buildup. The shields of lead followed by polyethylene now have significantly lower buildup. This effect is hence

referred to as a “buildup reversal”. Most of the response in the case of lead followed by polyethylene is from annihilation photons created in the lead which are not attenuated in the polyethylene

3.27 Incident Photons of Energy 10 MeV

At 10 MeV, pair production is the most prominent interaction in lead, thus the effects seen at 6 MeV are magnified.

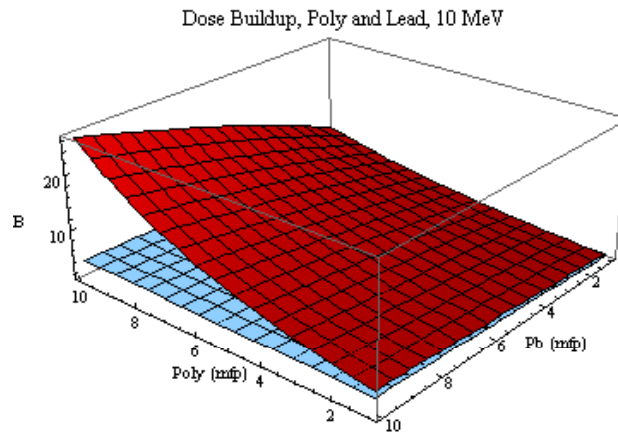

Figure 3.271 Dose Buildup Factors for 6 MeV photons incident on shields of polyethylene and lead of varying thicknesses The blue surface lead followed by polyethylene and the red is polyethylene followed by lead.

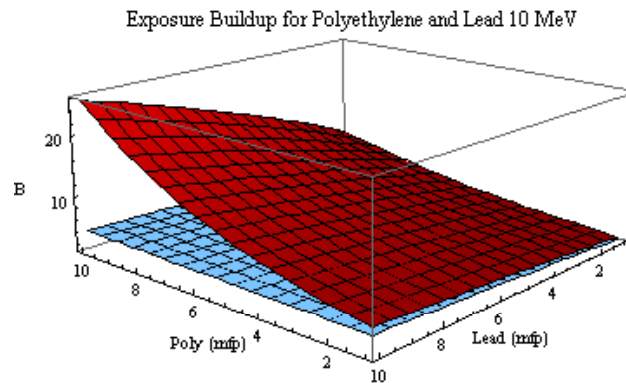

Figure 3.272 Exposure Buildup Factors for 6 MeV photons incident on shields of polyethylene and lead of varying thicknesses The blue surface lead followed by polyethylene and the red is polyethylene followed by lead.

At 2 and 6 MeV, while some photons were scattered into the “trough”, many were scattered below the trough where they experienced increased photoelectric absorption. At 10 MeV however, a larger fraction will be scattered into the “trough” thus increasing the total response and hence buildup. Also, the increased cross section due to pair production decreases the unscattered term, and increases annihilation photons which also, in turn, increases buildup.

3.3 Polyethylene and Stainless Steel

Several differences between lead and stainless steel affect the photon transport through each material. In photoelectric absorption, the k-edge in stainless steel happens at a much lower energy (around 10 keV) than in lead (at 88 keV). The pair production cross section in stainless steel at 10 MeV is less than half that of lead at the same energy. Thus several effects, such as the jump in buildup in the 100 keV range and the buildup reversal seen at high intermediate energies are absent. The mass interaction coefficients are plotted below as a function of energy.

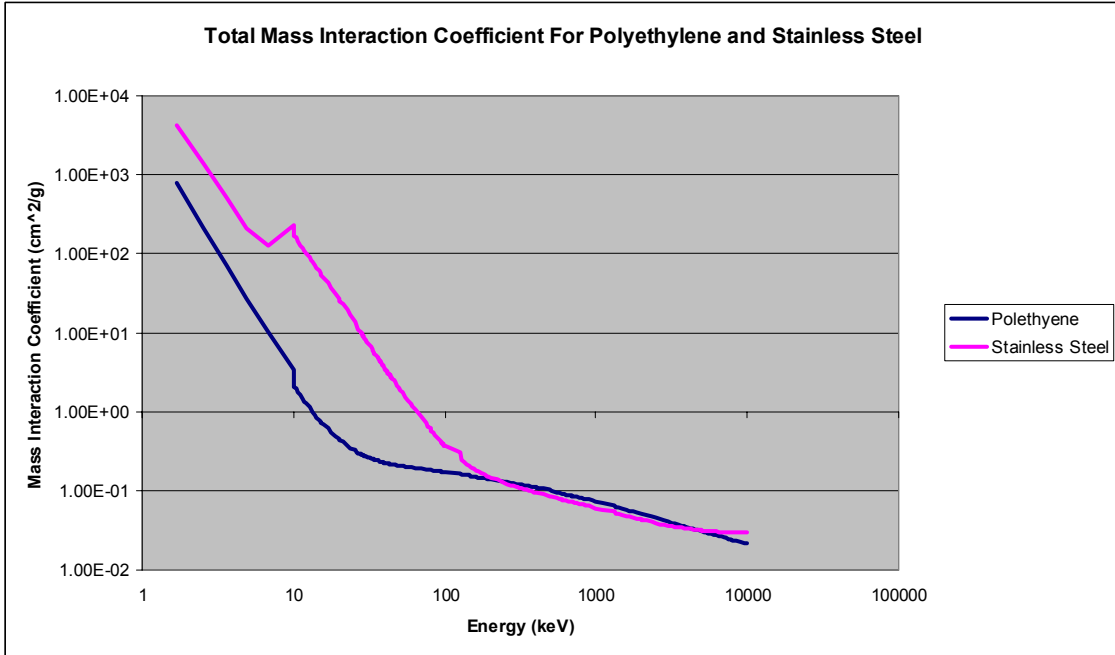

Figure 3.31 Total Mass Interaction coefficients for polyethylene and stainless steel

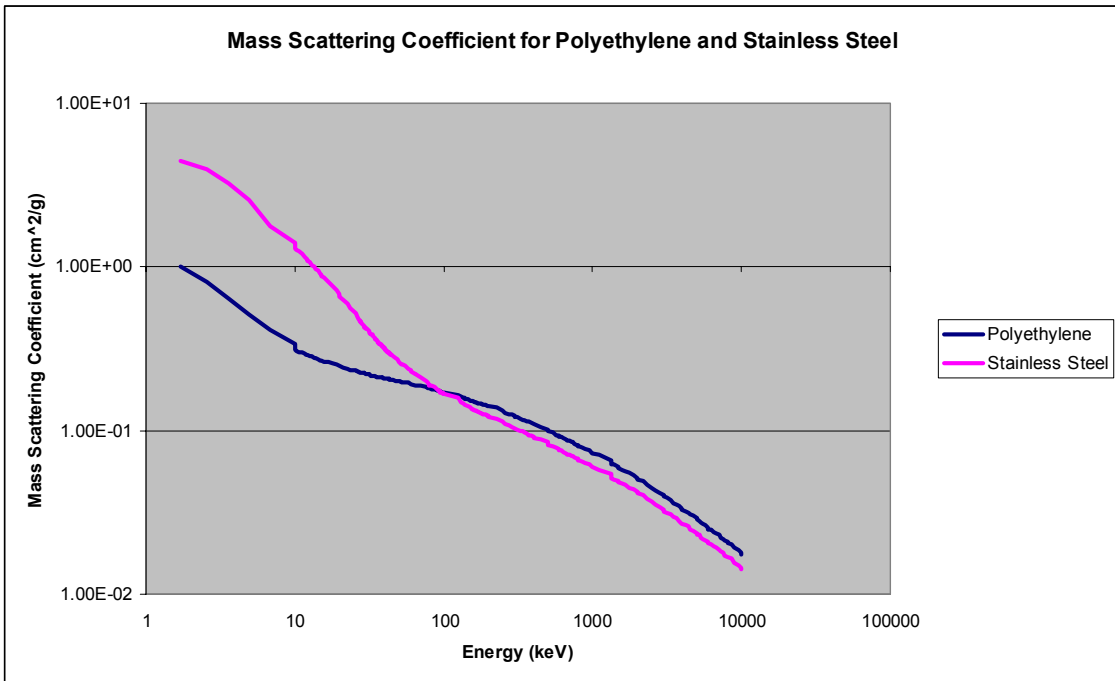

Figure 3.32 Mass Scattering coefficients for polyethylene and stainless steel

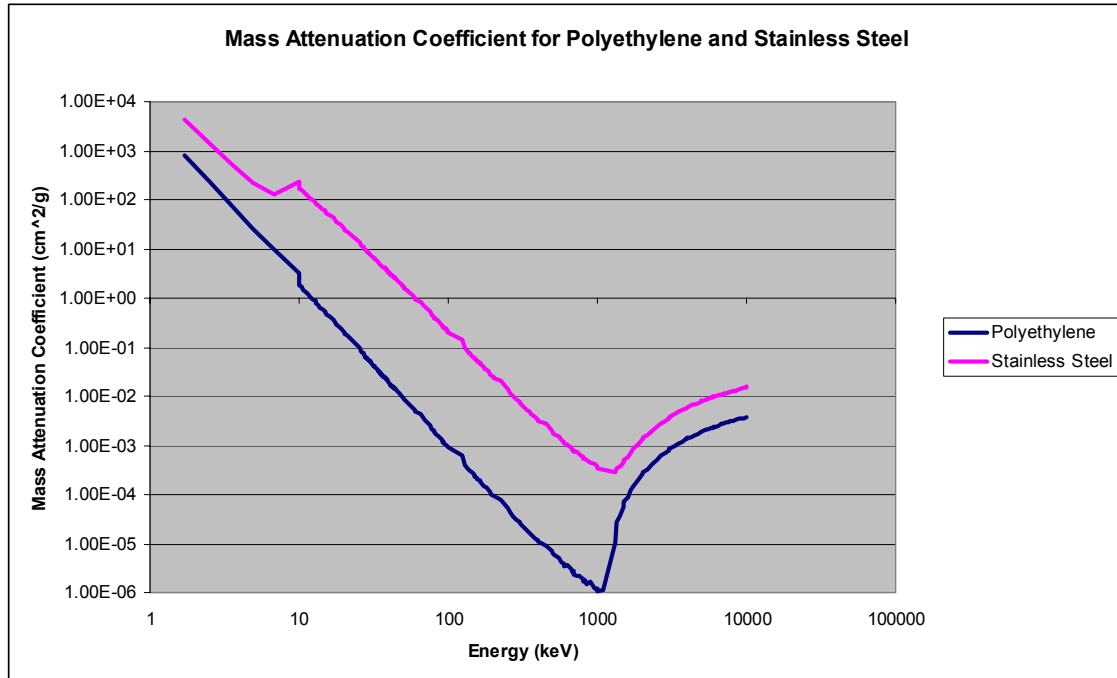

Figure 3.33 Mass Attenuation coefficients for polyethylene and stainless steel

Comparing these plots to the corresponding plots for lead and polyethylene at low energies, the photoelectric absorption cross section is one and a half times as high in stainless steel as in lead, though it decreases much faster with increasing energy in stainless steel and is much lower at intermediate energies. This is also due to the lower energy k-edge in stainless steel. The discontinuous drops in the photoelectric cross section for lead corresponding to the ejection of various shell electrons causes it to be lower at lower energies than the corresponding cross-section for stainless steel. The scattering (mainly coherent) cross section is slightly lower at low energies for stainless steel.

3.31 Incident Photons of 65 keV

Despite obvious differences in the cross-sections for certain energy ranges of lead and stainless steel, in many energy ranges, they produce similar results. This is true at 65 keV

thus the same explanation suffices here; for shields beginning with polyethylene, the 65 keV photons are Compton scattered to a lower energy where they experience a higher photoelectric cross section in the lead thus affecting a lower flux and hence buildup. In the reverse case, the photons not attenuated by the lead layer will be largely unscattered photons. They will experience Compton scattering in the stainless steel but will not be attenuated, creating a higher flux and buildup.

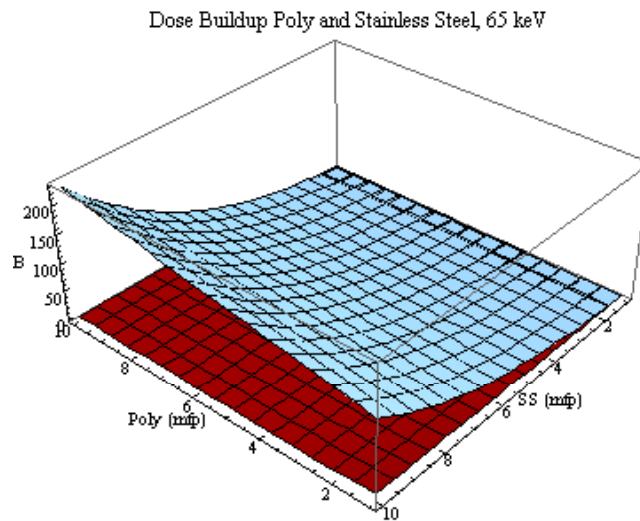

Figure 3.311 Dose Buildup Factors for 65 keV photons incident on shields of polyethylene and stainless steel of varying thicknesses. The blue surface is stainless steel followed by polyethylene and the red is polyethylene followed by stainless steel.

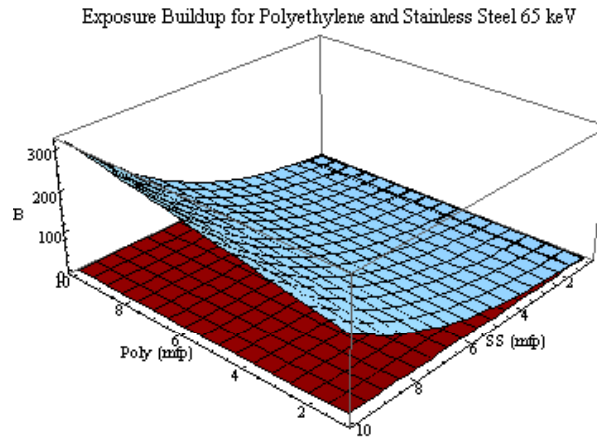

Figure 3.312 Exposure Buildup Factors for 65 keV photons incident on shields of polyethylene and stainless steel of varying thicknesses. The blue surface is stainless steel followed by polyethylene and the red is polyethylene followed by stainless steel.

3.32 Incident Photons of 100 keV

As was evident in section 3.2, shields involving lead (or other high-Z materials) have much higher buildup factors in the energy range just above 88 keV due to the k-edge. Since the k-edge is much lower for stainless steel, we do not observe the same effect for 100 keV incident photons.

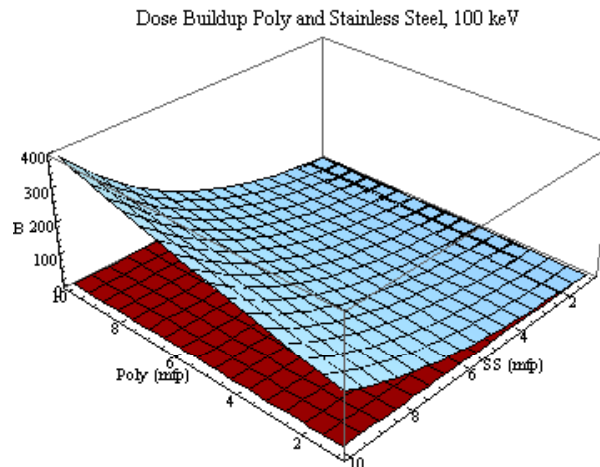

Figure 3.321 Dose Buildup Factors for 100 keV photons incident on shields of polyethylene and stainless steel of varying thicknesses. The blue surface is stainless steel followed by polyethylene and the red is polyethylene followed by stainless steel.

Recall from figure 2.31, that the dose response below 100 keV increases for an interval before decreasing at the lower energies. Because photoelectric absorption is the dominant process at this energy, the dose comes primarily from uncollided, source photons which undergo slight Compton scattering in the polyethylene. Since the dose response is increasing for a significant interval at less than 100 keV, the scattered photons make a significant contribution to dose. This accounts in part for the high buildup factors for shields of stainless steel followed by polyethylene.

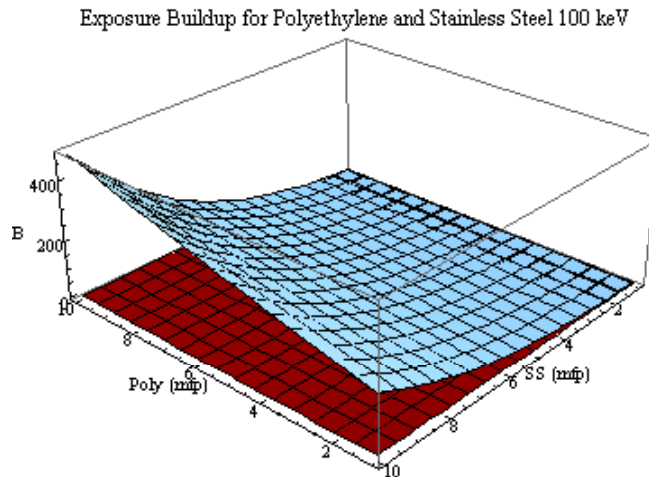

Figure 3.322 Exposure Buildup Factors for 100 keV photons incident on shields of polyethylene and stainless steel of varying thicknesses. The blue surface is stainless steel followed by polyethylene and the red is polyethylene followed by stainless steel.

3.33 Incident Photons of 500 keV

At 500 keV, Compton scattering is the predominant process in both materials. In light of this, the following results at first seem anomalous. Shields in which scattering dominates should have higher buildup factors than those where absorption dominates. The key to these results lies in the response function. Unlike the previous case, the dose response function is decreasing below 500 keV until it reaches the range discussed in 3.31. Though there is more

Compton scattering and hence, buildup, the dose response function is decreasing so there is lower dose buildup.

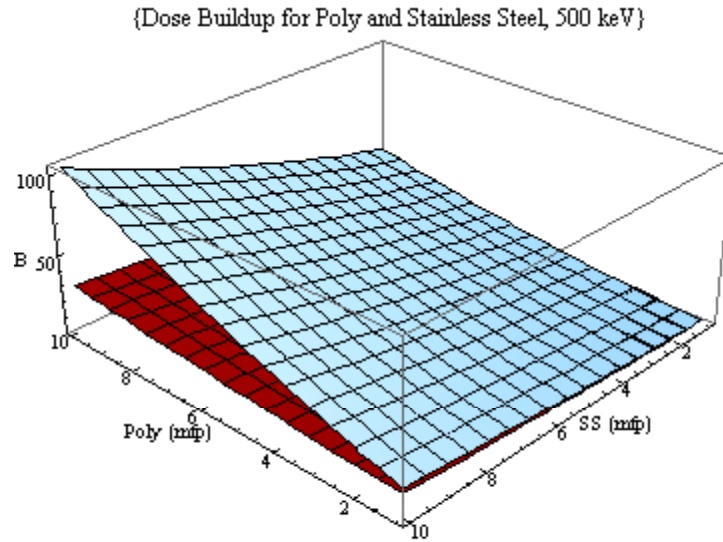

Figure 3.331 Dose Buildup Factors for 500 keV photons incident on shields of polyethylene and stainless steel of varying thicknesses. The blue surface is stainless steel followed by polyethylene and the red is polyethylene followed by stainless steel.

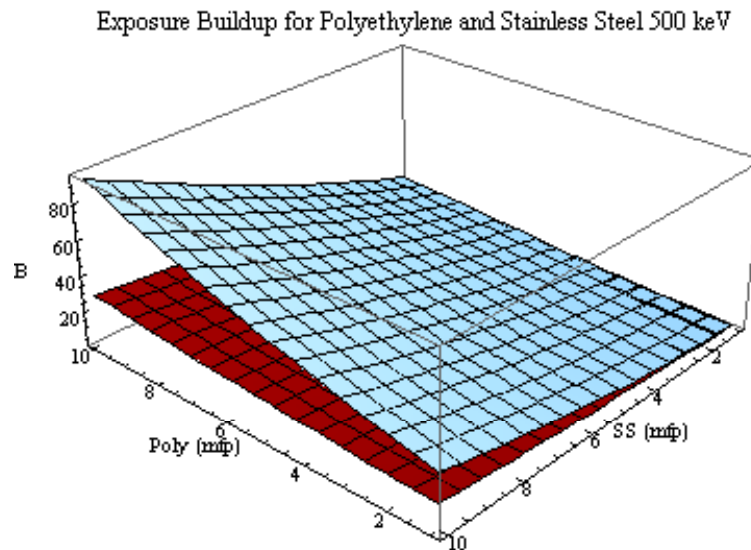

Figure 3.332 Exposure Buildup Factors for 500 keV photons incident on shields of polyethylene and stainless steel of varying thicknesses. The blue surface is stainless steel followed by polyethylene and the red is polyethylene followed by stainless steel.

3.34 Incident Photons of 1 MeV

Compton scattering is strongly dominant at this energy in both materials. For shields of polyethylene followed by stainless steel, the incident 1 MeV photons will be Compton scattered in the polyethylene to lower energies, which are more subject to photoelectric absorption in the stainless steel. Thus, this configuration has lower buildup than the reverse case.

The dose buildup for stainless steel followed by polyethylene is less at this energy than at the previous energies because the dose from scattered photons is decreasing. Since the dose response is decreasing at and below this energy, and Compton scattering is predominant, the dose from the unscattered photons is higher (due to the higher response function). As the incident particle energy increases, with the exception of the case discussed in section 3.32, the response function gives more and more weight to the unscattered photons. Thus the buildup will continue to decrease.

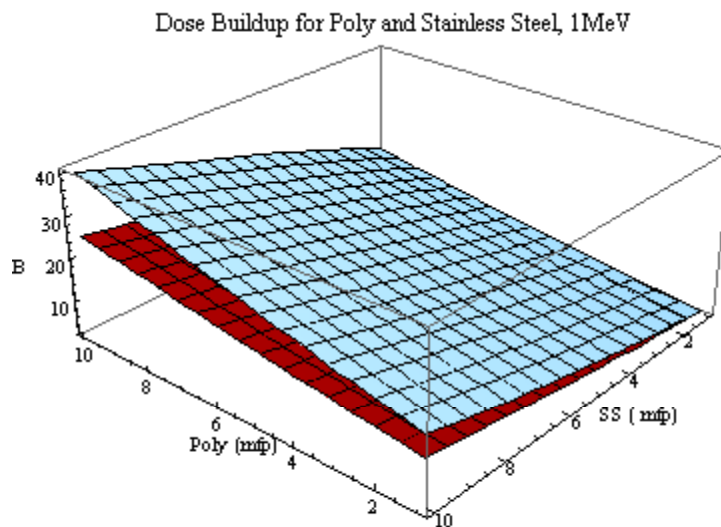

Figure 3.341 Dose Buildup Factors for 1 MeV photons incident on shields of polyethylene and stainless steel of varying thicknesses. The blue surface is stainless steel followed by polyethylene and the red is polyethylene followed by stainless steel.

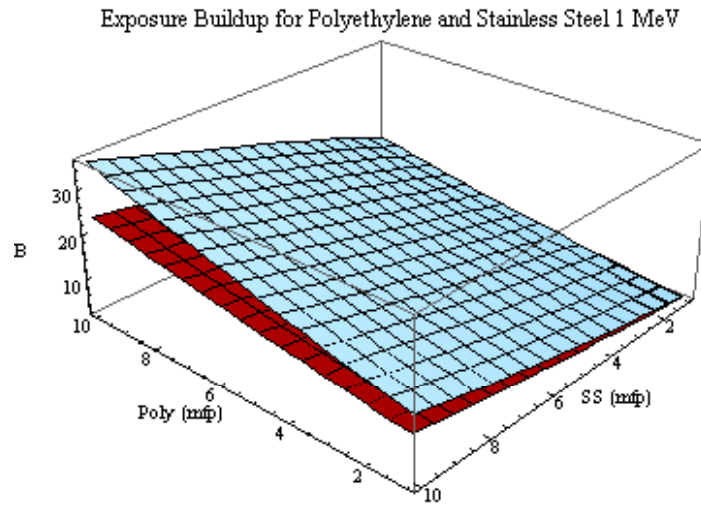

Figure 3.342 Exposure Buildup Factors for 1 MeV photons incident of shields of polyethylene and stainless steel of varying thicknesses. The blue surface is stainless steel followed by polyethylene and the red is polyethylene followed by stainless steel.

3.35 Incident Photons of 2 MeV

Though Compton scattering is the dominant process in both materials for 2 MeV, pair production, while still small, is beginning to increase. Similar to the configurations of polyethylene and lead, shields beginning in polyethylene, will Compton-scatter photons below the 1.022 MeV threshold for pair production which is more dominant in stainless steel, though still a factor of 2 less than in lead.

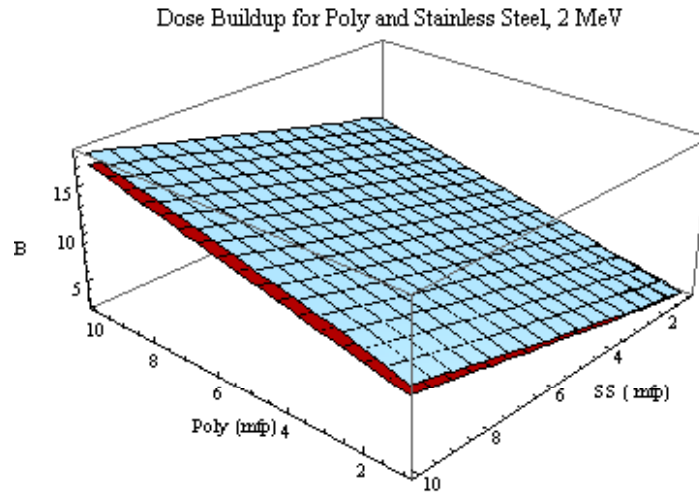

Figure 3.351 Dose Buildup Factors for 2 MeV photons incident on shields of polyethylene and stainless steel of varying thicknesses. The blue surface is stainless steel followed by polyethylene and the red is polyethylene followed by stainless steel.

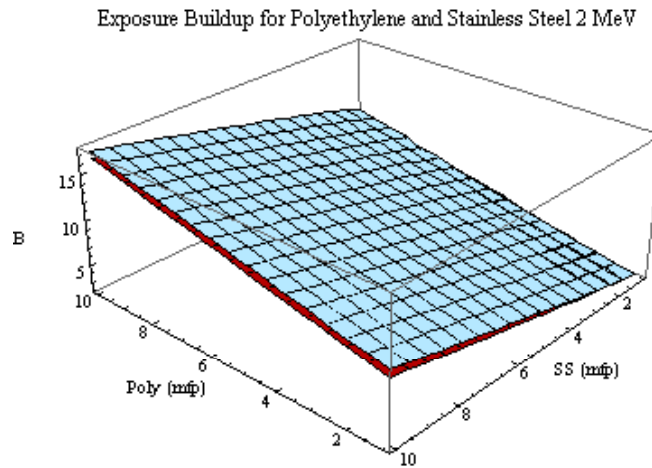

Figure 3.352 Exposure Buildup Factors for 2 MeV photons incident on shields of polyethylene and stainless steel of varying thicknesses. The blue surface is stainless steel followed by polyethylene and the red is polyethylene followed by stainless steel.

At this energy, the cross sections for the two materials are very similar. Thus the order of the materials will be less important than for other cases.

3.36 Incident Photons of 6 MeV

Similarly to the case of 6 MeV photons incident on shields of polyethylene followed by lead, when photons in this energy range are incident on shields of polyethylene, many are Compton-scattered either below the 1.022 MeV pair-production threshold or to an energy experiencing a lower pair-production cross-section. This causes the flux to increase relative to the unscattered flux which is still experiencing the higher pair-production cross-section; hence the buildup decreases less than that for the case of stainless steel followed by polyethylene.

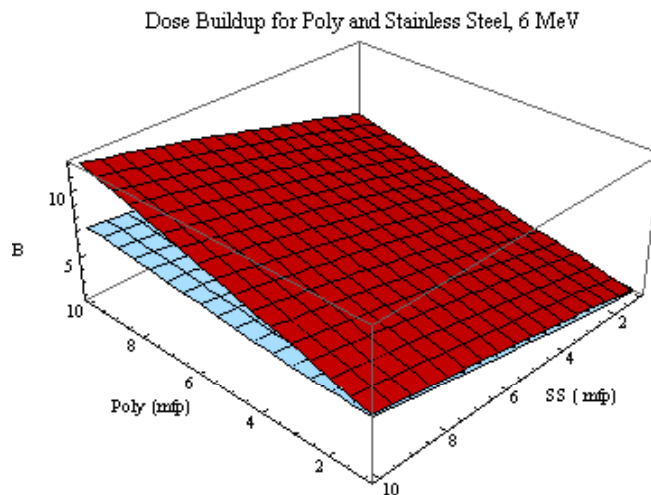

Figure 3.361 Dose Buildup Factors for 6 MeV photons incident on shields of polyethylene and stainless steel of varying thicknesses. The blue surface is stainless steel followed by polyethylene and the red is polyethylene followed by stainless steel.

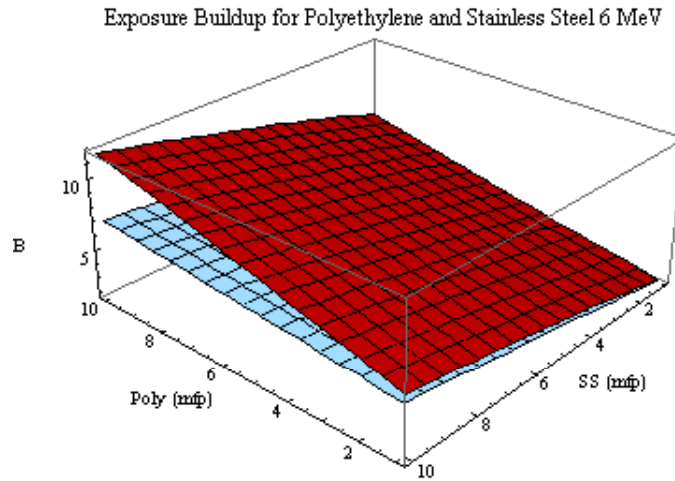

Figure 3.362 Exposure Buildup Factors for 6 MeV photons incident on shields of polyethylene and stainless steel of varying thicknesses. The blue surface is stainless steel followed by polyethylene and the red is polyethylene followed by stainless steel.

3.37 Incident Photons of 10 MeV

At 10 MeV, the effects discussed for 6 MeV incident photons are magnified. The main difference between the two cases is that at 10 MeV, the total cross section for stainless steel is roughly constant down to around 6 MeV. Thus, the Compton-scattered photons in the configuration of stainless steel followed by aluminum see nearly the same total cross sections as the uncollided photons before escaping the lead. This implies that the scattered and unscattered flux will be very close together and the buildup will be small. In figure 3.371, we see the evidence of this, where the main difference in the buildup is attributable to the dose response function.

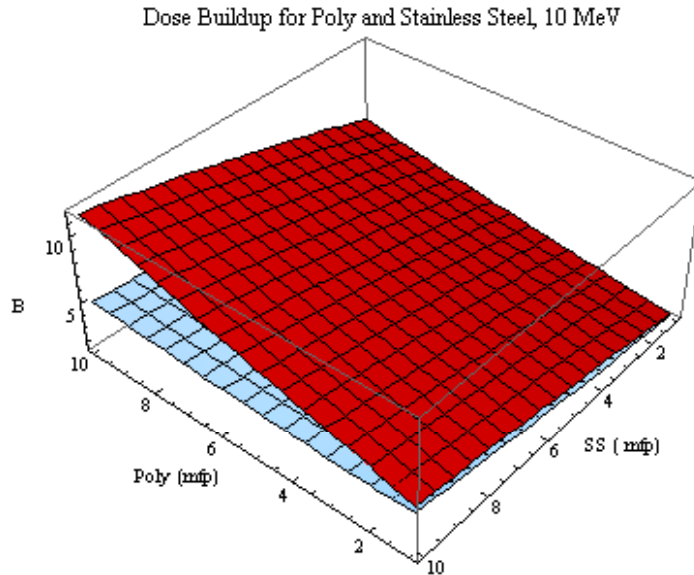

Figure 3.371 Dose Buildup Factors for 10 MeV photons incident on shields of polyethylene and stainless steel of varying thicknesses. The blue surface is stainless steel followed by polyethylene and the red is polyethylene followed by stainless steel.

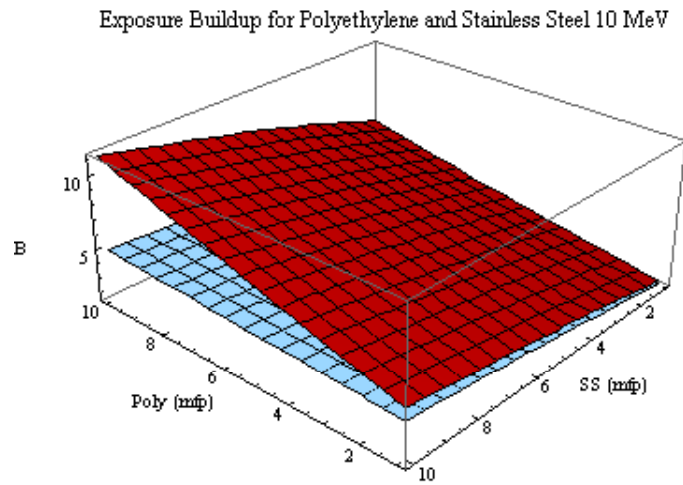

Figure 3.372 Exposure Buildup Factors for 10 MeV photons incident on shields of polyethylene and stainless steel of varying thicknesses. The blue surface is stainless steel followed by polyethylene and the red is polyethylene followed by stainless steel.

3.4 Aluminum and Lead

In the following several sections, as well in the next chapter, where dose and exposure results are presented, most results will be presented with less analysis. With a few

exceptions, the major physical phenomena have been explained in sections 3.2 and 3.3 and will be referred to as necessary. In the cases with results dissimilar to those previously discussed, a more thorough treatment will be given. Cross-section plots are provided for examination with each set of materials as was done in the previous sections.

In the following plots, the similarities between the polyethylene and lead cases are evident. Though the mass coefficients are higher for aluminum than polyethylene, they exhibit the same shape and features. This implies that though the magnitude of the buildup will change, the same effects will be exhibited by both sets of shields.

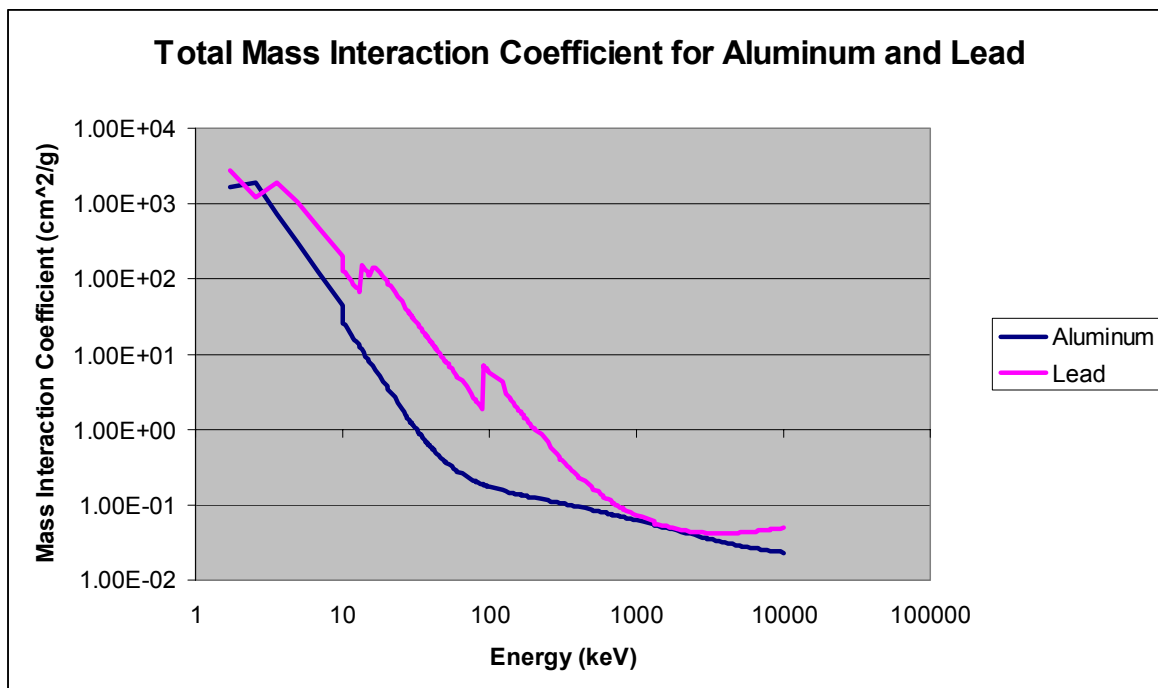

Figure 3.41 total Mass Interaction coefficients aluminum and lead

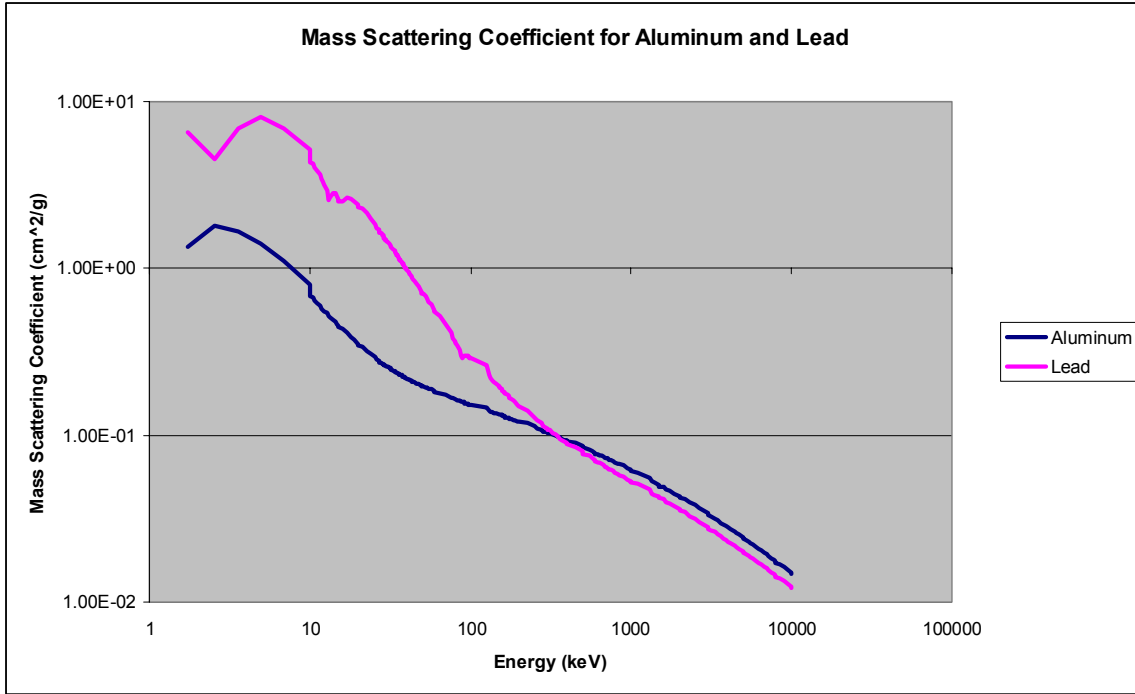

Figure 3.42 Total Mass Scattering coefficients for aluminum and lead

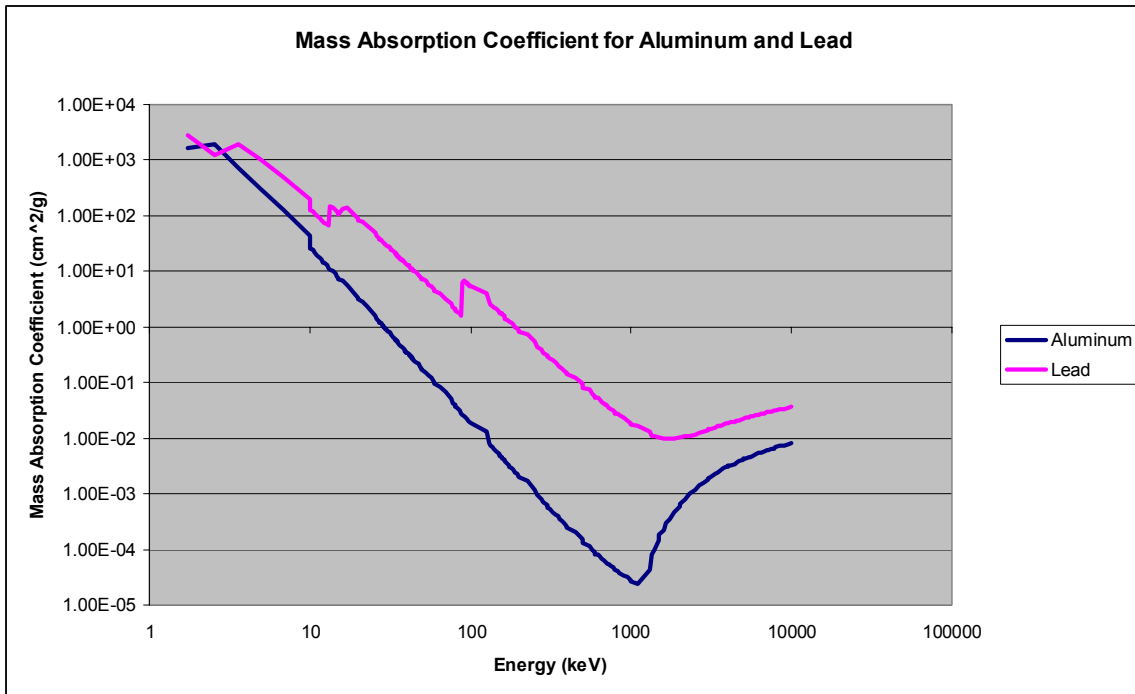

Figure 3.43 Total Mass Absorption coefficients for aluminum and lead

3.41 Incident Photons of 65 keV

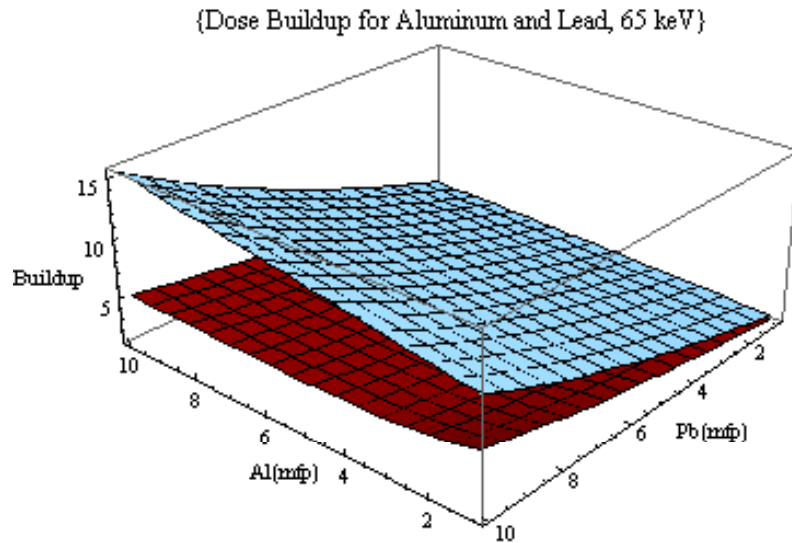

Figure 3.411 Dose Buildup Factors for 65 keV photons incident on shields of lead and aluminum of varying thicknesses. The blue surface is lead followed by aluminum and the red is aluminum followed by lead.

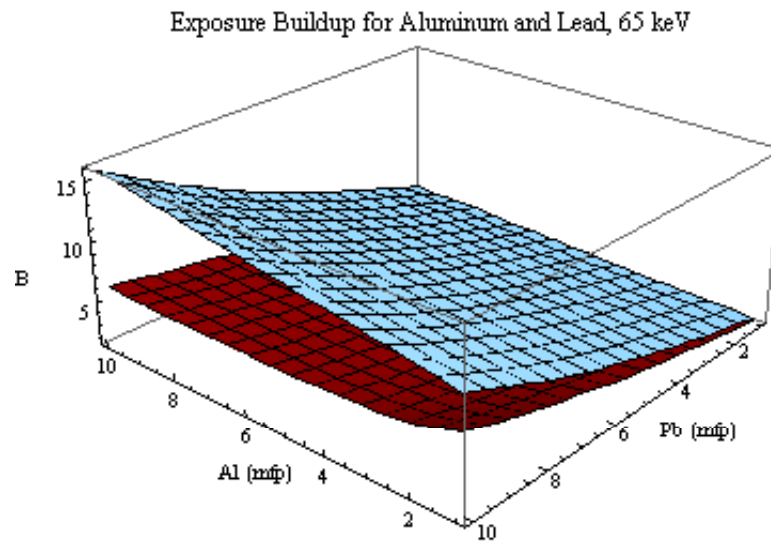

Figure 3.412 Exposure Buildup Factors for 65 keV photons incident on shields of lead and aluminum of varying thicknesses. The blue surface is lead followed by aluminum and the red is aluminum followed by lead.

One distinguishing characteristic of this 65 keV plot is the slight decrease in buildup with increasing aluminum thickness for shields of aluminum followed by thick lead layers. This is due to the high photoelectric cross section at low energies for aluminum. As the shield thickness increases, the scattered flux decreases faster than the uncollided flux for thinner aluminum layers. As the layer gets thicker, this effect disappears and the ratio remains roughly constant.

3.42 Incident Photons of 100 keV

Aluminum's photoelectric cross-section is an order of magnitude higher than polyethylene. Thus, unlike the case of polyethylene and lead, where the buildup was only lightly dependent on material order, here more photons will be absorbed at this energy in the lower-Z material (aluminum). The order will then be extremely important. aluminum will more strongly absorb the Compton-scattered photons at this energy than will the lead. Thus the buildup for shields of aluminum followed by lead will be higher.

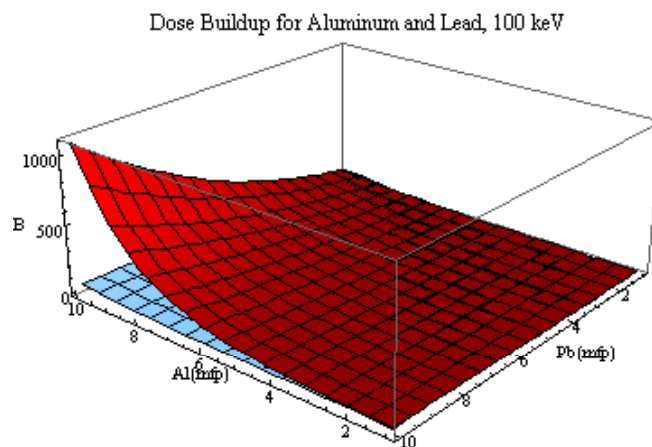

Figure 3.421 Dose Buildup Factors for 100 keV photons incident on shields of lead and aluminum of varying thicknesses. The blue surface is lead followed by aluminum and the red is aluminum followed by lead.

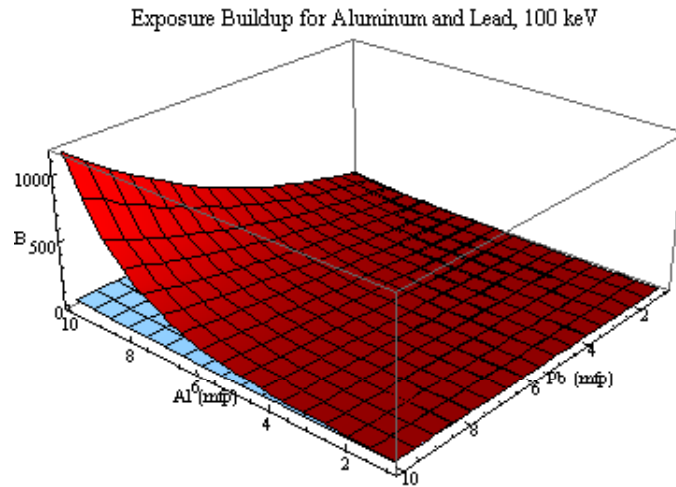

Figure 3.422 Exposure Buildup Factors for 100 keV photons incident of shields of lead and aluminum of varying thicknesses. The blue surface is lead followed by aluminum and the red is aluminum followed by lead.

3.43 Incident Photons of 500 keV

As in the cases involving lead and polyethylene, the 500 keV case shows a return to a trend similar to the 65 keV case. However, the buildup is lower due to the higher cross-sections

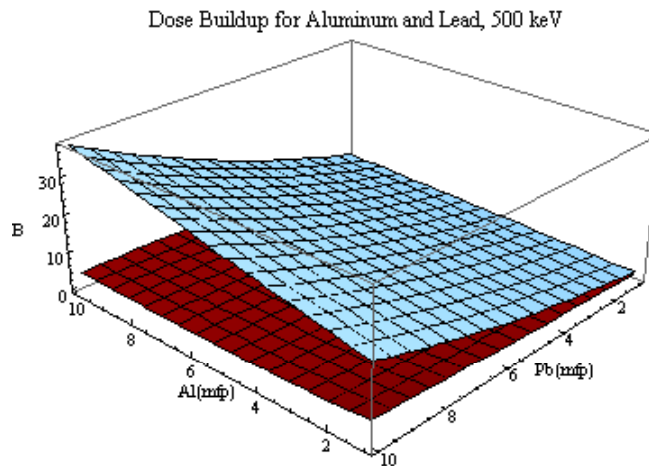

Figure 3. 431 Dose Buildup Factors for 500 keV photons incident on shields of lead and aluminum of varying thicknesses. The blue surface is lead followed by aluminum and the red is aluminum followed by lead.

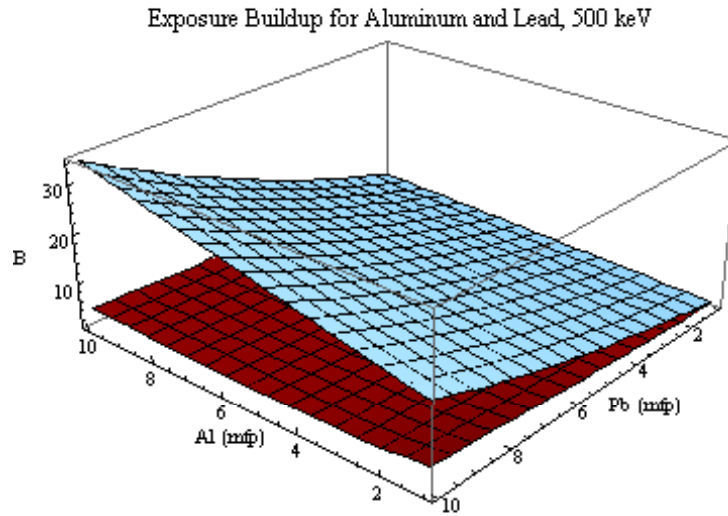

Figure 3. 432 Exposure Buildup Factors for 500 keV photons incident on shields of lead and aluminum of varying thicknesses. The blue surface is lead followed by aluminum and the red is aluminum followed by lead.

3.44 Incident Photons of 1 MeV

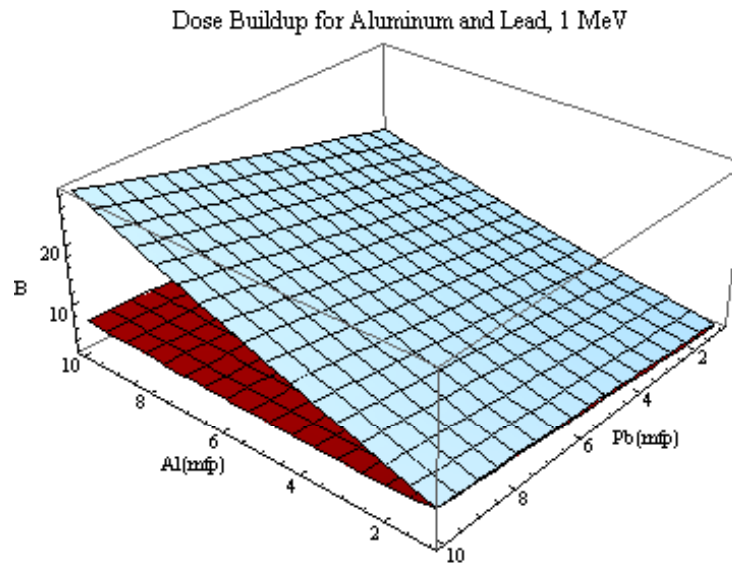

Figure 3. 441 Dose Buildup Factors for 1 MeV photons incident on shields of lead and aluminum of varying thicknesses. The blue surface is lead followed by aluminum and the red is aluminum followed by lead.

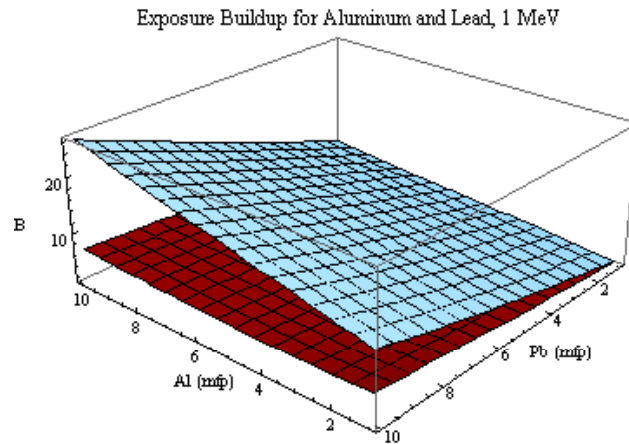

Figure 3.442 Exposure Buildup Factors for 1 MeV photons incident on shields of lead and aluminum of varying thicknesses. The blue surface is lead followed by aluminum and the red is aluminum followed by lead.

3.45 Incident Photons of 2 MeV

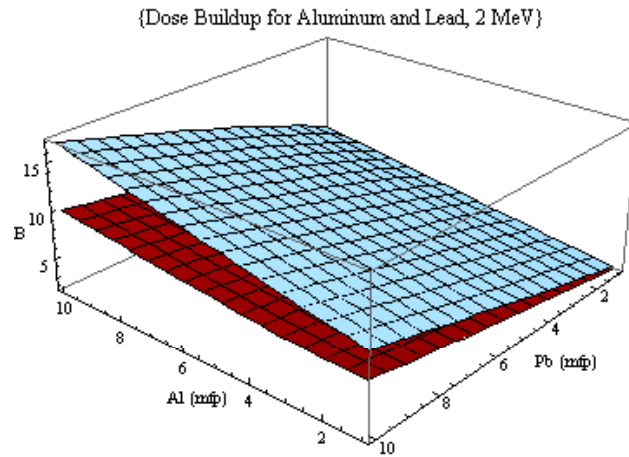

Figure 3. 451 Dose Buildup Factors for 2 MeV photons incident on shields of lead and aluminum of varying thicknesses. The blue surface is lead followed by aluminum and the red is aluminum followed by lead.

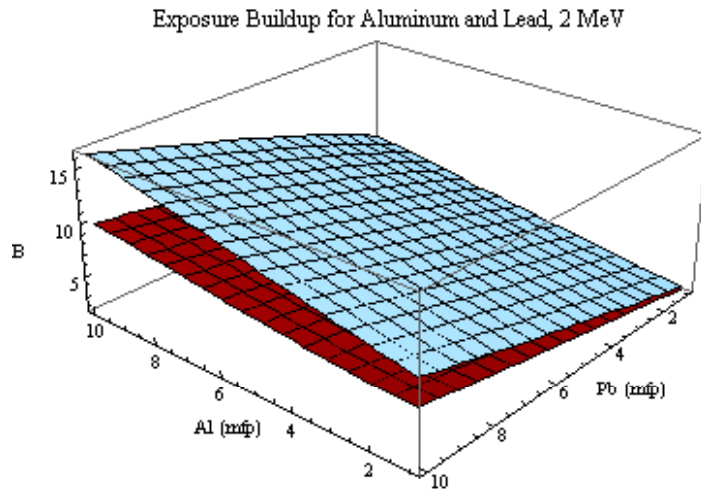

Figure 3.452 Exposure Buildup Factors for 2 MeV photons incident on shields of lead and aluminum of varying thicknesses. The blue surface is lead followed by aluminum and the red is aluminum followed by lead.

3.46 Incident Photons of 6 MeV

As in the cases of lead or stainless steel and polyethylene, the buildup reversal due to pair production occurs around 6 MeV.

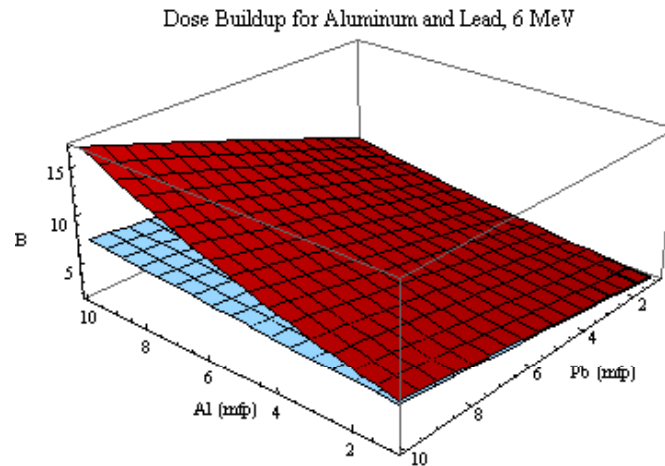

Figure 3.461 Dose Buildup Factors for 6 MeV photons incident on shields of lead and aluminum of varying thicknesses. The blue surface is lead followed by aluminum and the red is aluminum followed by lead.

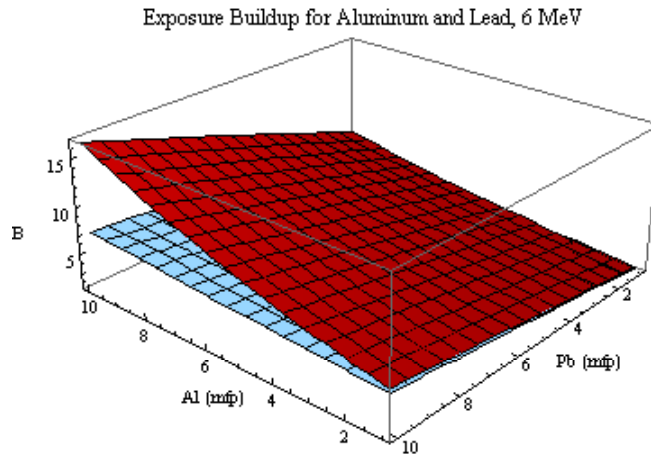

Figure 3.462 Exposure Buildup Factors for 6 MeV photons incident on shields of lead and aluminum of varying thicknesses. The blue surface is lead followed by aluminum and the red is aluminum followed by lead.

3.47 Incident Photons of 10 MeV

As in the polyethylene and lead or stainless steel configurations, the effects present at 6 MeV are magnified at 10 MeV.

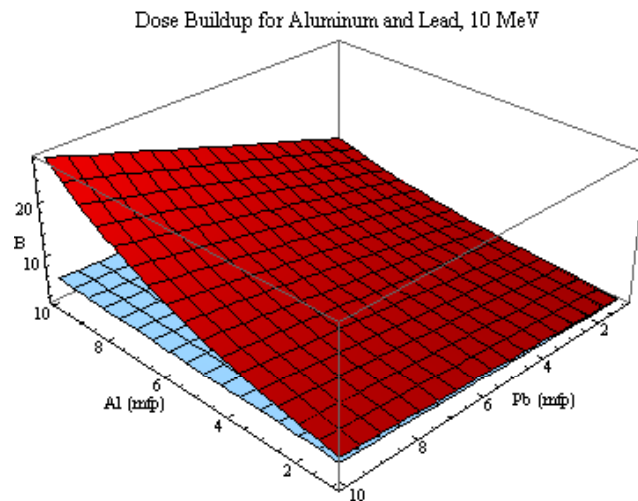

Figure 3.471 Dose Buildup Factors for 10 MeV photons incident of shields on lead and aluminum of varying thicknesses. The blue surface is lead followed by aluminum and the red is aluminum followed by lead.

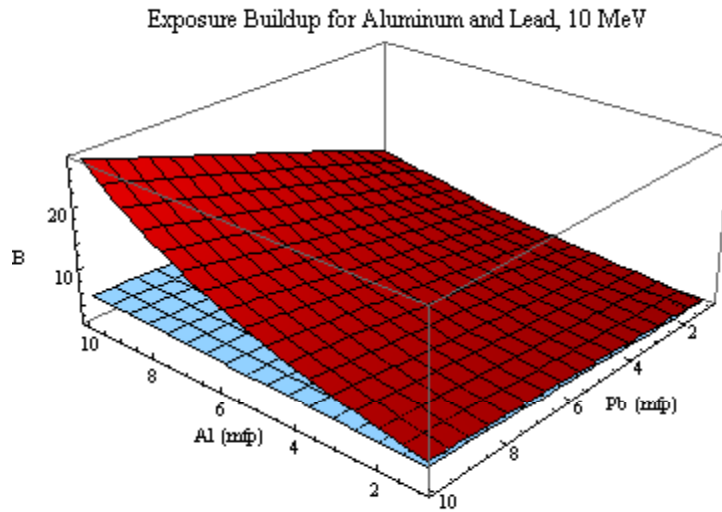

Figure 3.472 Exposure Buildup Factors for 10 MeV photons incident on shields of lead and aluminum of varying thicknesses. The blue surface is lead followed by aluminum and the red is aluminum followed by lead.

3.5 Aluminum and Stainless Steel

As in section 3.4, where the results resembled those for polyethylene and lead, the aluminum and stainless steel results will resemble the polyethylene and stainless steel results.

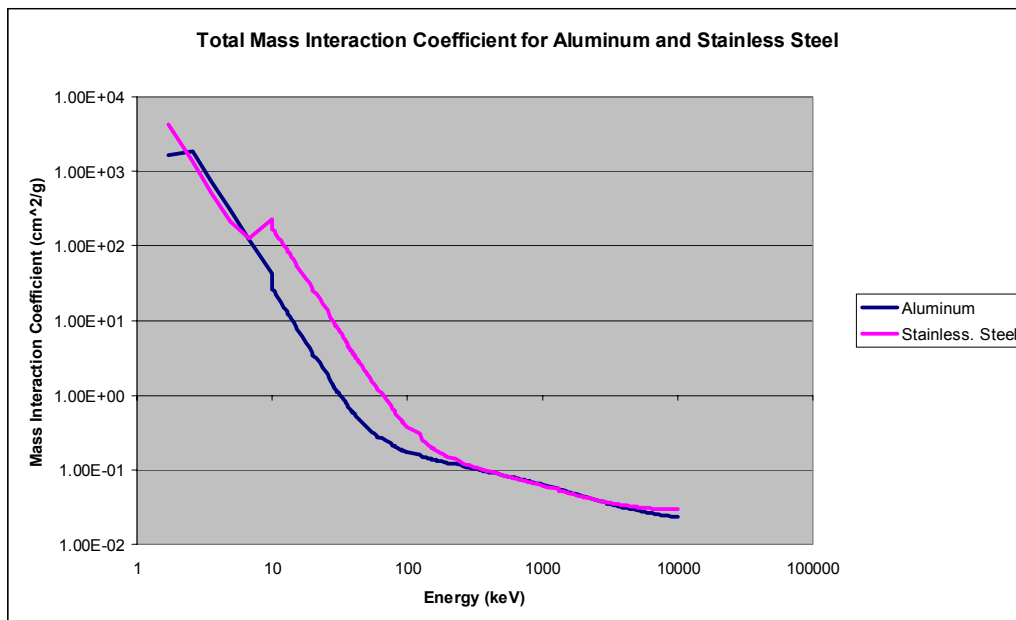

Figure 3.51 Mass Interaction Coefficient (coherent and incoherent scattering) for polyethylene and lead

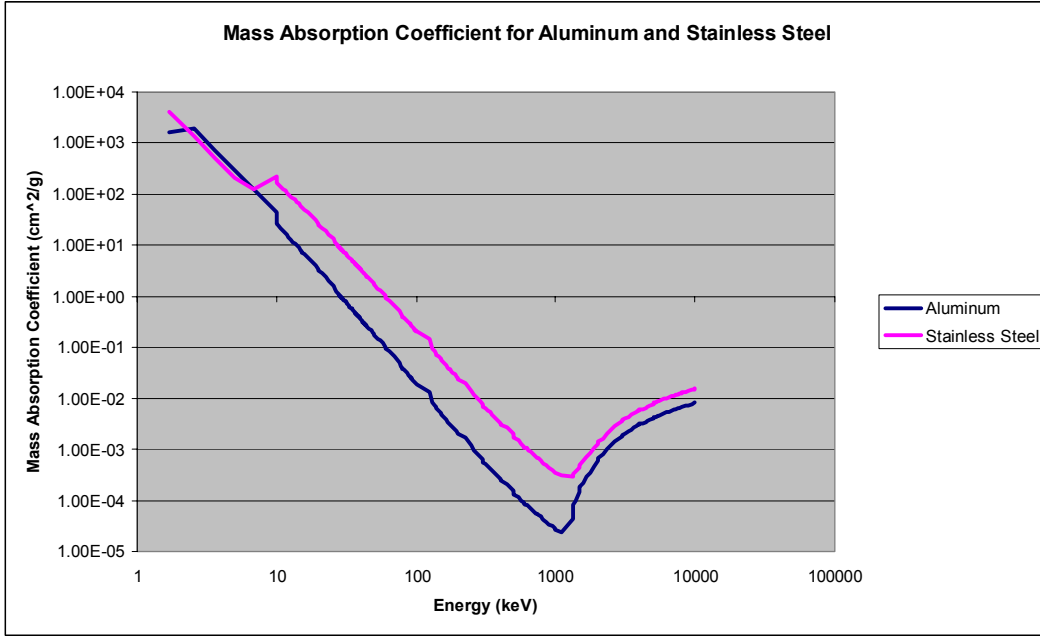

Figure 3.52 Mass Interaction Coefficient (coherent and incoherent scattering) for polyethylene and lead

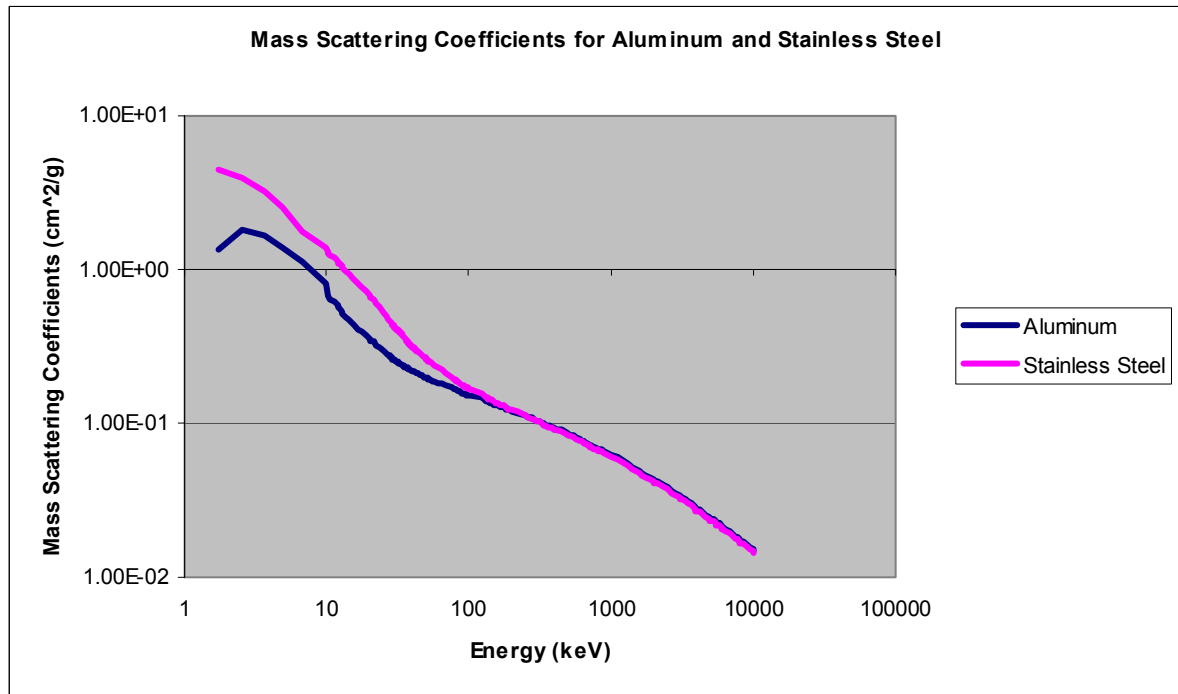

Figure 3.53 Mass Interaction Coefficient (coherent and incoherent scattering) for polyethylene and lead

3.51 Incident Photons of 65 keV

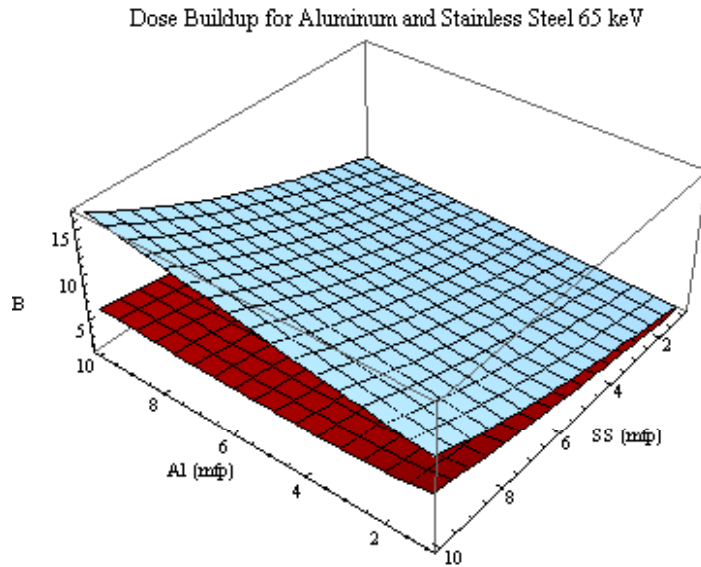

Figure 3.511 Dose Buildup Factors for 65 keV photons incident on shields of aluminum and stainless steel of varying thicknesses. The blue surface is lead followed by aluminum and the red is aluminum followed by lead.

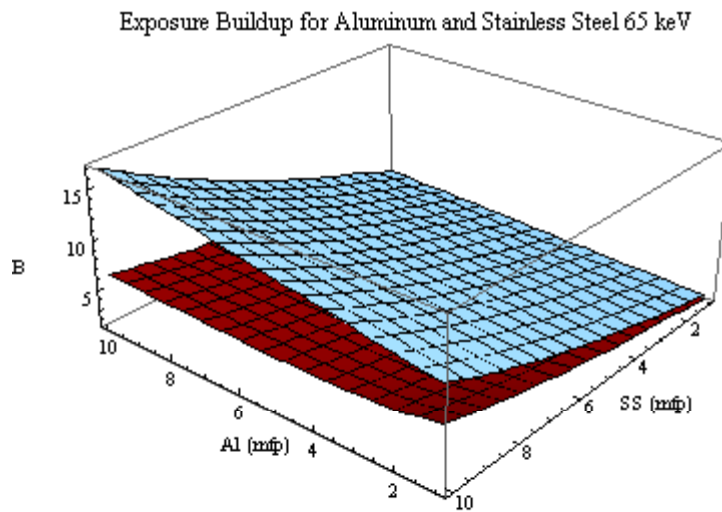

Figure 3.512 Exposure Buildup Factors for 65 keV photons incident on shields of aluminum and stainless steel of varying thicknesses. The blue surface is lead followed by aluminum and the red is aluminum followed by lead.

3.52 Incident Photons of 100 keV

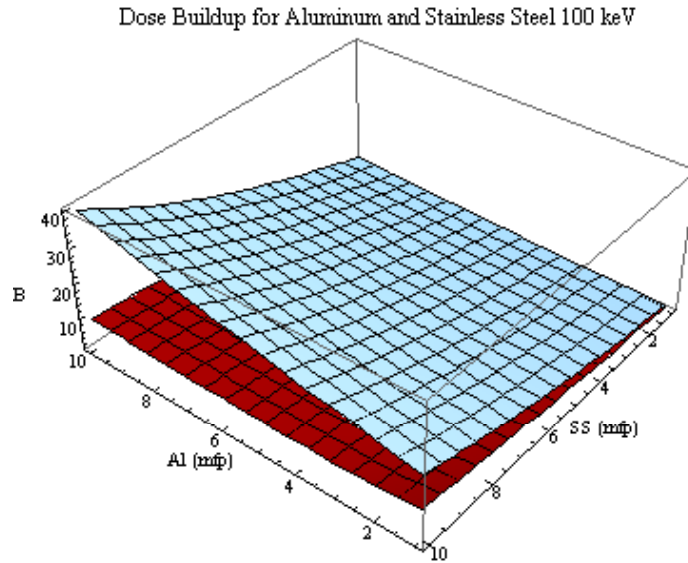

Figure 3.521 Dose Buildup Factors for 100 keV photons incident on shields of aluminum and stainless steel of varying thicknesses. The blue surface is lead followed by aluminum and the red is aluminum followed by lead.

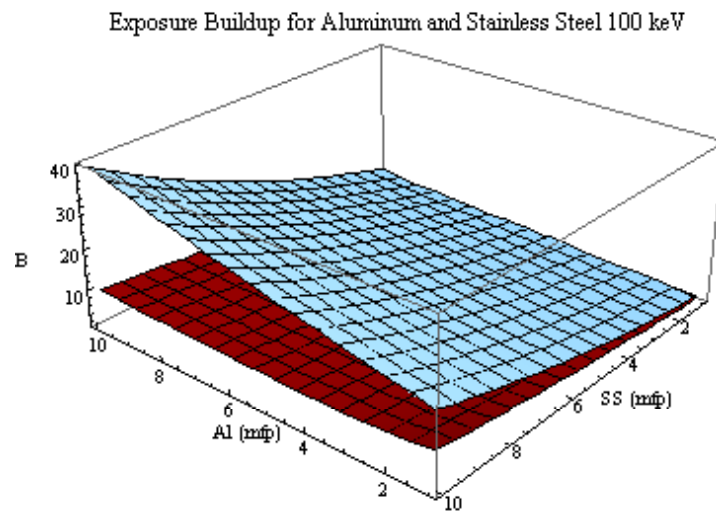

Figure 3.522 Exposure Buildup Factors for 100 keV photons incident on shields of aluminum and stainless steel of varying thicknesses. The blue surface is lead followed by aluminum and the red is aluminum followed by lead.

3.53 Incident Photons of 500 keV

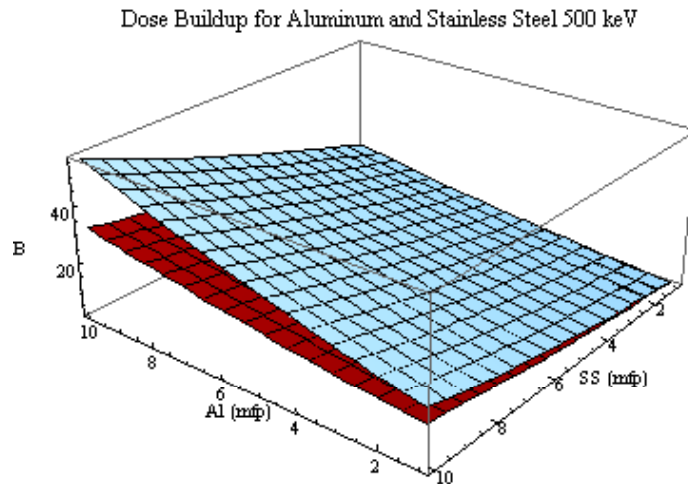

Figure 3.531 Dose Buildup Factors for 500 keV photons incident on shields of aluminum and stainless steel of varying thicknesses. The blue surface is lead followed by aluminum and the red is aluminum followed by lead.

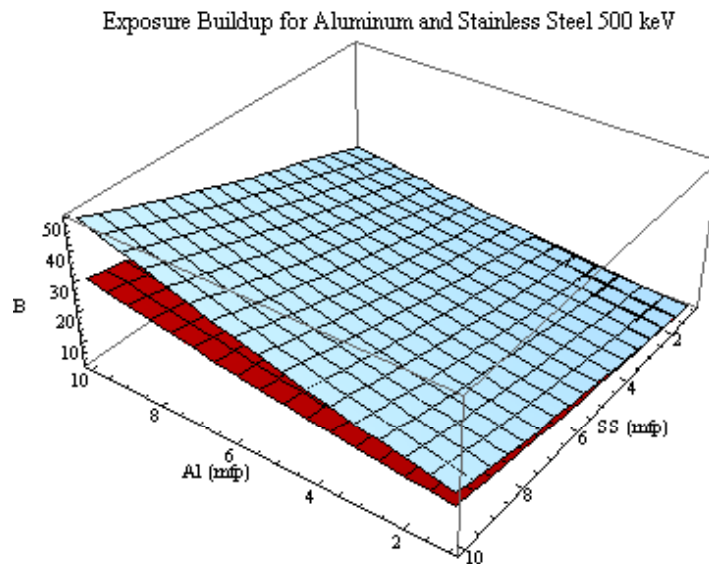

Figure 3.532 Exposure Buildup Factors for 500 keV photons incident on shields of aluminum and stainless steel of varying thicknesses. The blue surface is lead followed by aluminum and the red is aluminum followed by lead.

3.54 Incident Photons of 1 MeV

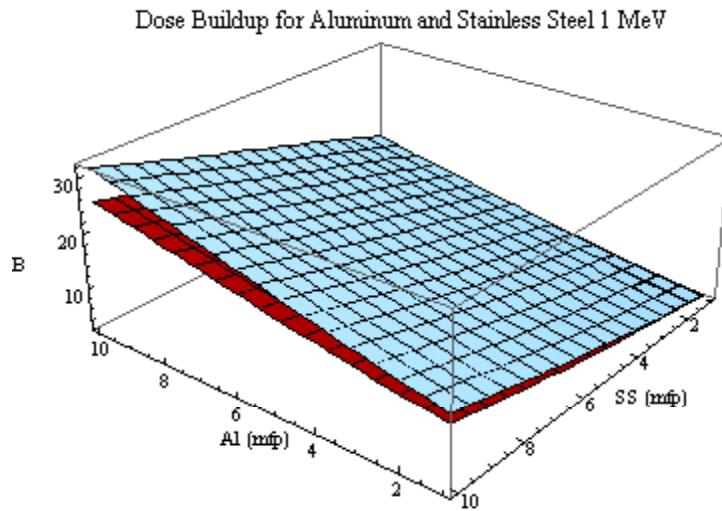

Figure 3.541 Dose Buildup Factors for 1 MeV photons incident on shields of aluminum and stainless steel of varying thicknesses. The blue surface is lead followed by aluminum and the red is aluminum followed by lead.

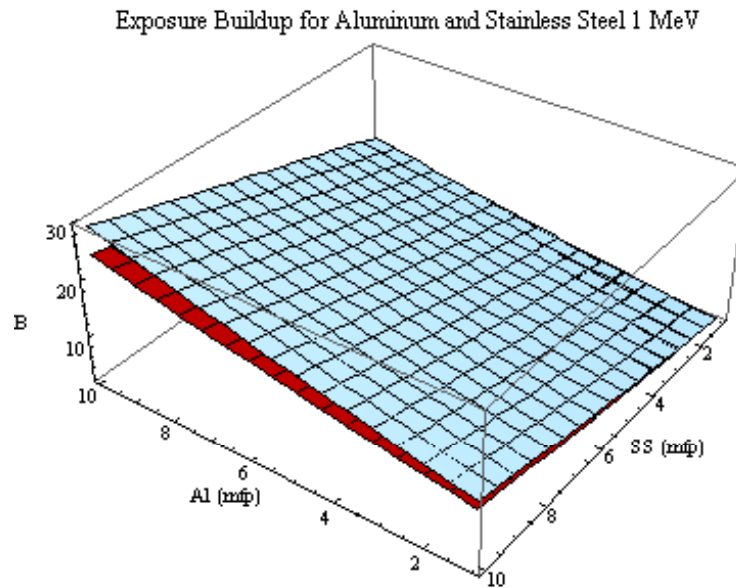

Figure 3.542 Exposure Buildup Factors for 1 MeV photons incident on shields of aluminum and stainless steel of varying thicknesses. The blue surface is lead followed by aluminum and the red is aluminum followed by lead.

3.55 Incident Photons of 2 MeV

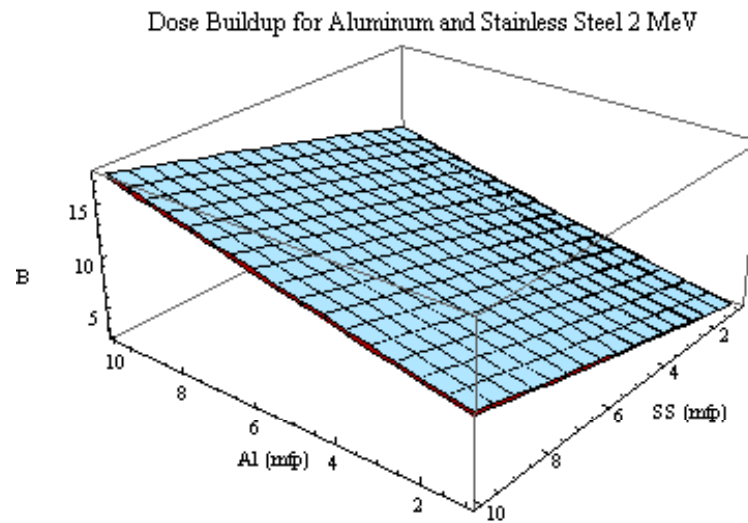

Figure 3.551 Dose Buildup Factors for 2 MeV photons incident on shields of aluminum and stainless steel of varying thicknesses. The blue surface is lead followed by aluminum and the red is aluminum followed by lead

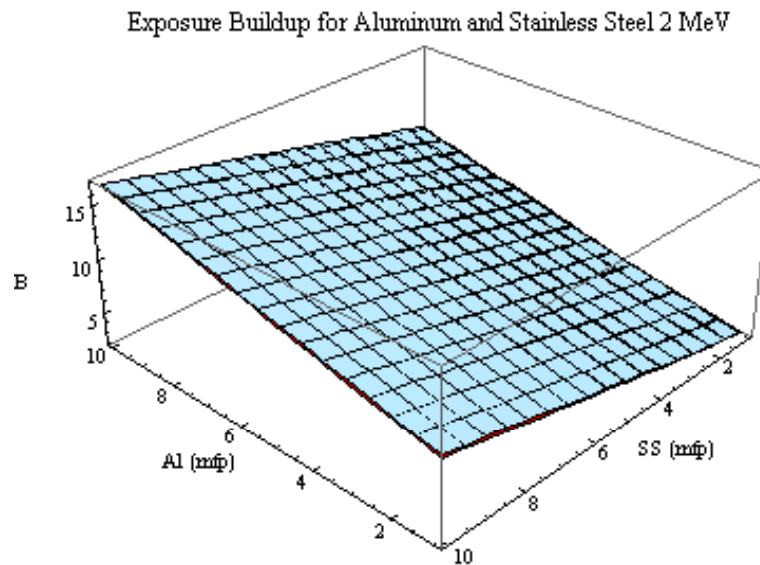

Figure 3.552 Exposure Buildup Factors for 2 MeV photons incident on shields of aluminum and stainless steel of varying thicknesses. The blue surface is lead followed by aluminum and the red is aluminum followed by lead

3.56 Incident Photons of 6 MeV

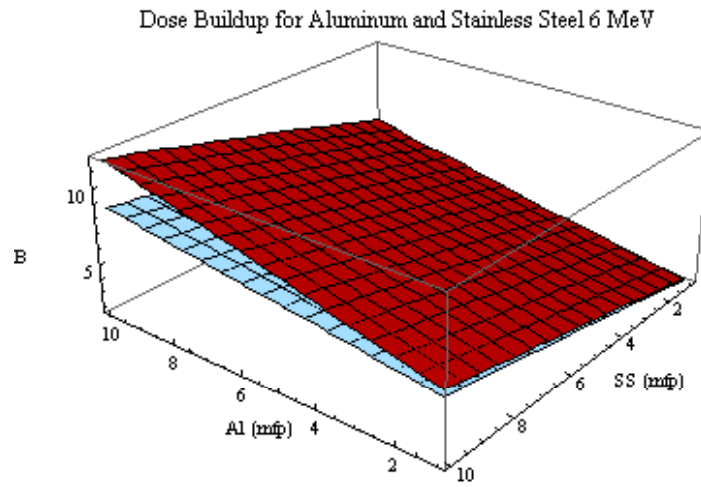

Figure 3.561 Dose Buildup Factors for 6 MeV photons incident on shields of aluminum and stainless steel of varying thicknesses. The blue surface is lead followed by aluminum and the red is aluminum followed by lead

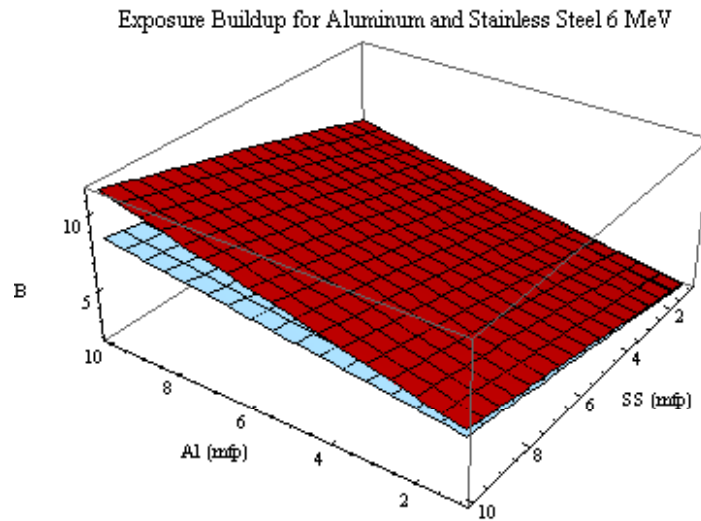

Figure 3.562 Exposure Buildup Factors for 6 MeV photons incident on shields of aluminum and stainless steel of varying thicknesses. The blue surface is lead followed by aluminum and the red is aluminum followed by lead

3.57 Incident Photons of 10 MeV

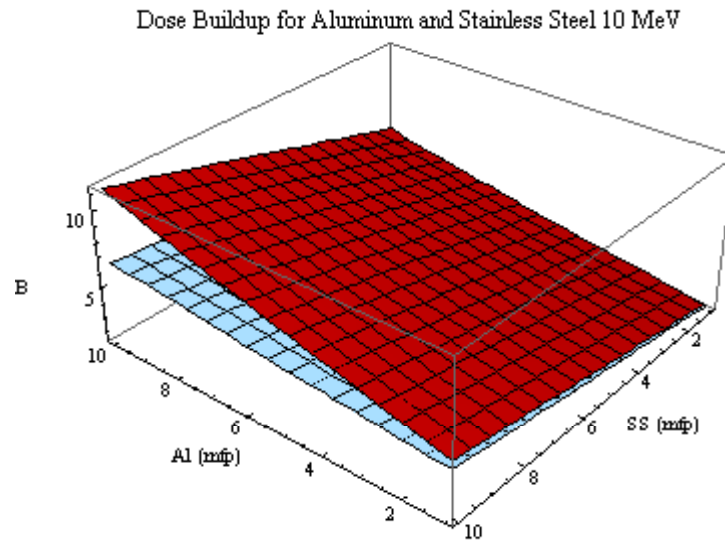

Figure 3.571 Dose Buildup Factors for 10 MeV photons incident on shields of aluminum and stainless steel of varying thicknesses. The blue surface is lead followed by aluminum and the red is aluminum followed by lead

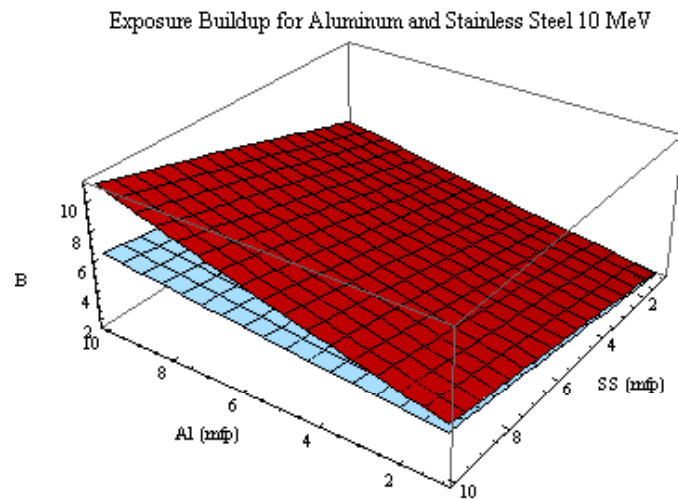

Figure 3.572 Exposure Buildup Factors for 10 MeV photons incident on shields of aluminum and stainless steel of varying thicknesses. The blue surface is lead followed by aluminum and the red is aluminum followed by lead

3.6 Stainless Steel and Lead

Stainless steel and lead are the heaviest materials examined in this research. The results are similar to those found for aluminum and lead, though effects are more pronounced.

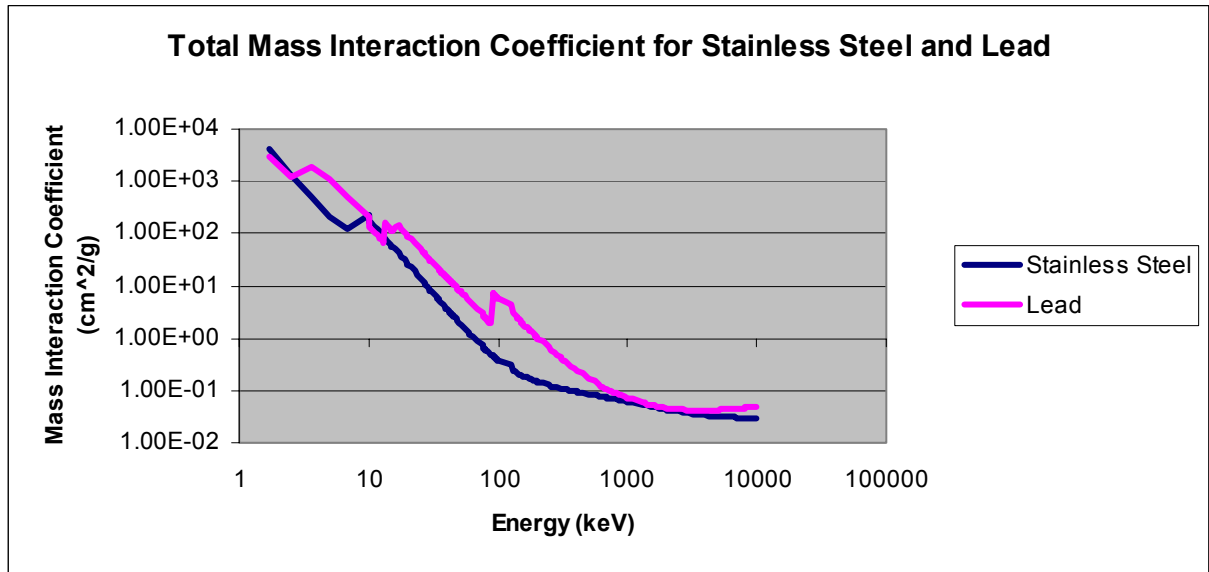

Figure 3.61 Mass Scattering Coefficient (coherent and incoherent scattering) for stainless steel and lead

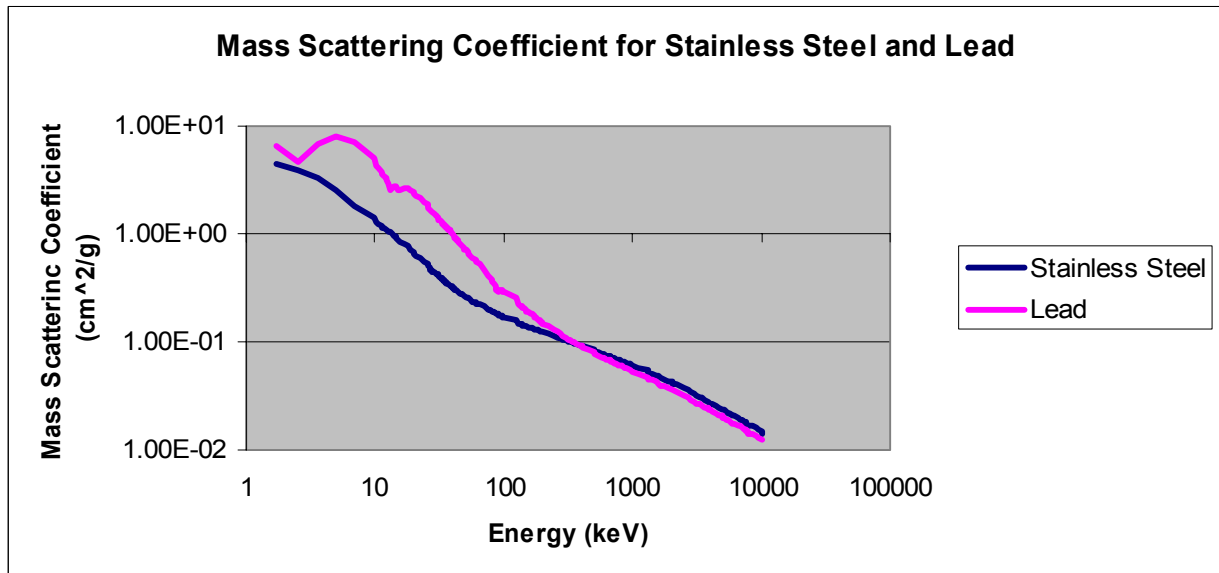

Figure 3.62 Mass Scattering Coefficient (coherent and incoherent scattering) for stainless steel and lead

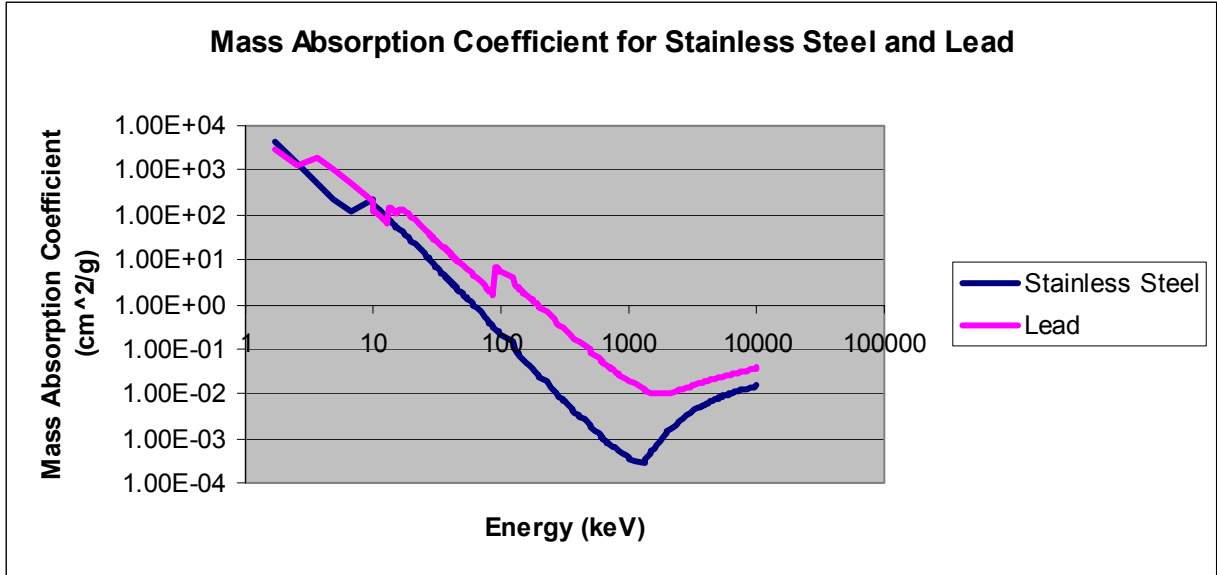

Figure 3.63 Mass Absorption Coefficient (coherent and incoherent scattering) for stainless steel and lead

3.61 Incident Photons of 65 keV

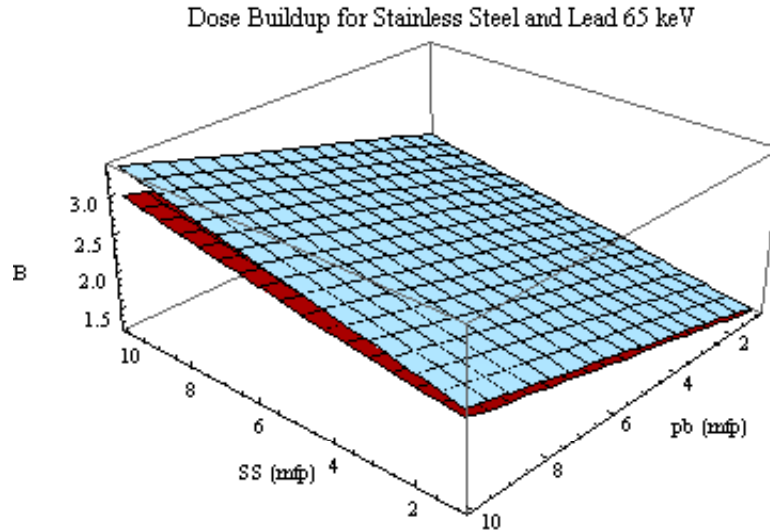

Figure 3.611 Dose Buildup Factors for 65 keV photons incident on shields of stainless steel and lead of varying thicknesses. The blue surface is lead followed by stainless steel and the red is stainless steel followed by lead

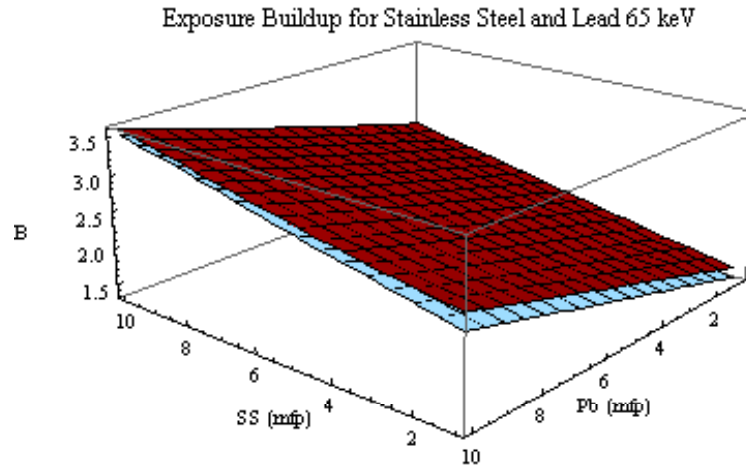

Figure 3.612 Exposure Buildup Factors for 65 keV photons incident on shields of stainless steel and lead of varying thicknesses. The blue surface is lead followed by stainless steel and the red is stainless steel followed by lead

This is the only configuration where the exposure buildup for a high Z material followed by a lower- Z material is lower than the exposure buildup for the reverse case. This is due to two factors. Unlike the other configurations, both constituent materials here have significantly higher absorption cross sections than scattering cross sections at this energy so fewer photons scatter to lower energies, and the ones that do are more readily absorbed. However, scattering is slightly more prominent (relative to absorption) in stainless steel. Therefore, photons will experience slight Compton scattering and the flux that impinges on the lead layer will be comprised of lower energy photons. This is evident in the following plot of the flux spectrum for this case:

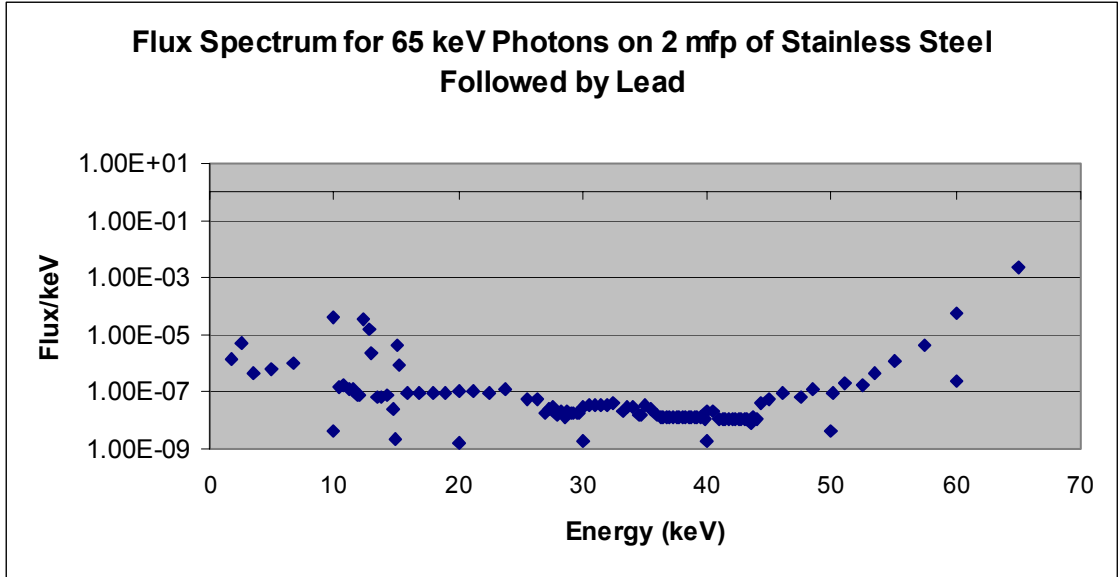

Figure 3.613 Flux spectrum for 65 keV photons incident on 2 mfp of stainless steel followed by lead

For reference, the following plot shows that the reverse case (lead followed by aluminum) has lower flux in the lower energies:

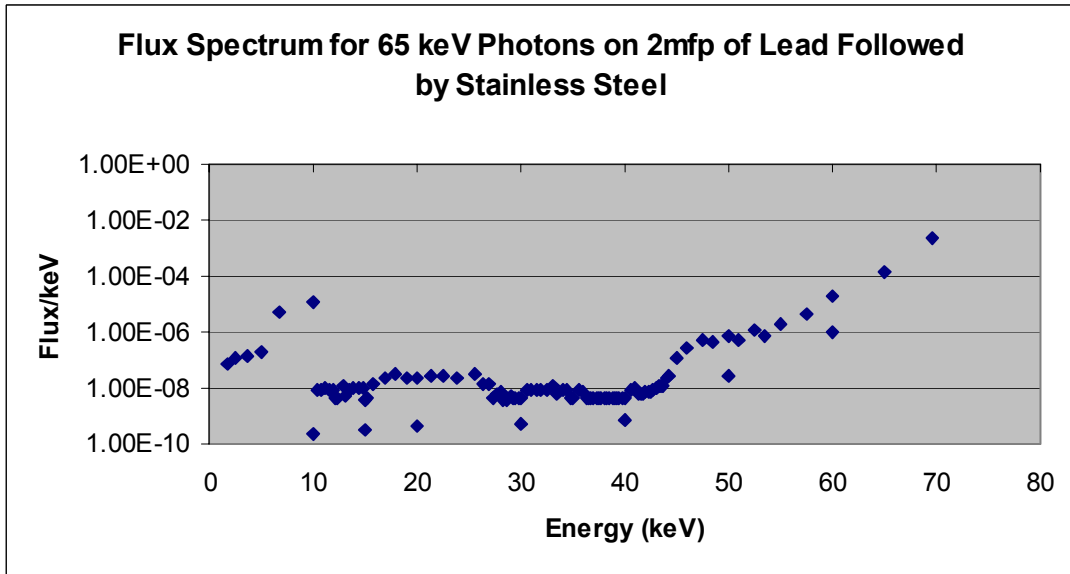

Figure 3.614 Flux Spectrum for 65 keV photons incident on 2 mfp lead followed by stainless steel

Recall that, in this energy range, the exposure response function increases with

decreasing energy. The higher low-energy flux for stainless steel followed by lead will then affect a higher exposure response from scattered photons and, consequently the buildup for stainless steel followed by lead will be higher.

3.62 Incident Photons of 100 keV

For 100 keV photons incident on shields of stainless steel followed by lead, Compton scattering dominates in the first, stainless steel layer. Many photons down scatter below the k-edge for lead and are more easily transported through the lead layer than the uncollided photons, thereby creating a higher buildup. In the reverse case of lead followed by stainless steel, as the k-edge for stainless steel is far below this energy, even the photons that Compton scatter below the k-edge for lead and are easily transported through the lead layer are absorbed in the stainless steel layer. This creates a much lower buildup. This is demonstrated in figures 3.621 and 3.622

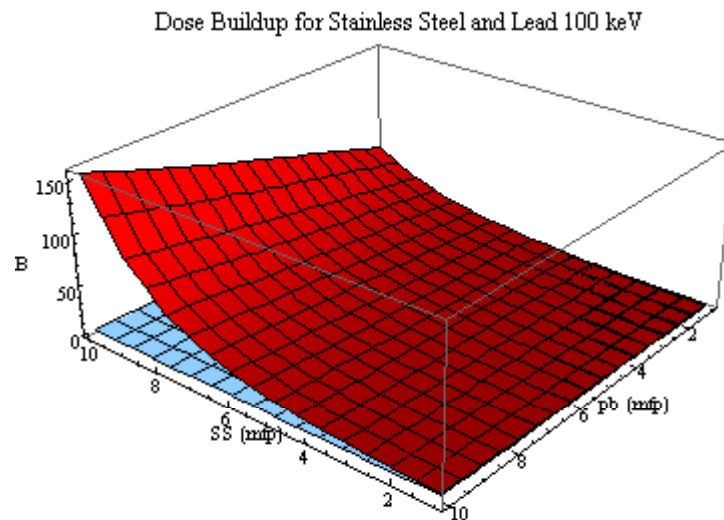

Figure 3.621 Dose Buildup Factors for 100 keV photons incident on shields of stainless steel and lead of varying thicknesses. The blue surface is lead followed by stainless steel and the red is stainless steel followed by lead.

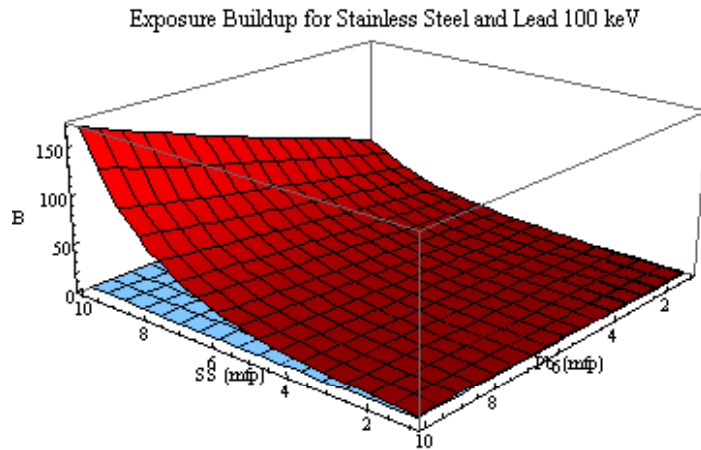

Figure 3.622 Exposure Buildup Factors for 100 keV photons incident on shields of stainless steel and lead of varying thicknesses. The blue surface is lead followed by stainless steel and the red is stainless steel followed by lead

3.63 Incident Photons of 500 keV

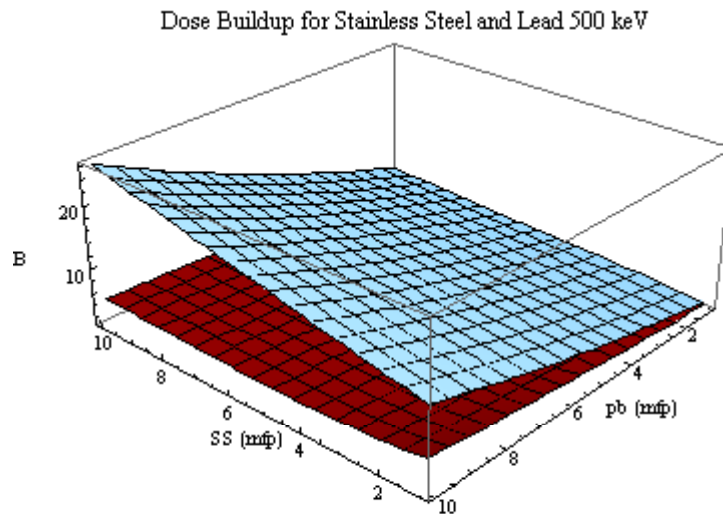

Figure 3.631 Dose Buildup Factors for 500 keV photons incident on shields of stainless steel and lead of varying thicknesses. The blue surface is lead followed by stainless steel and the red is stainless steel followed by lead

Exposure Buildup for Stainless Steel and Lead 500 keV

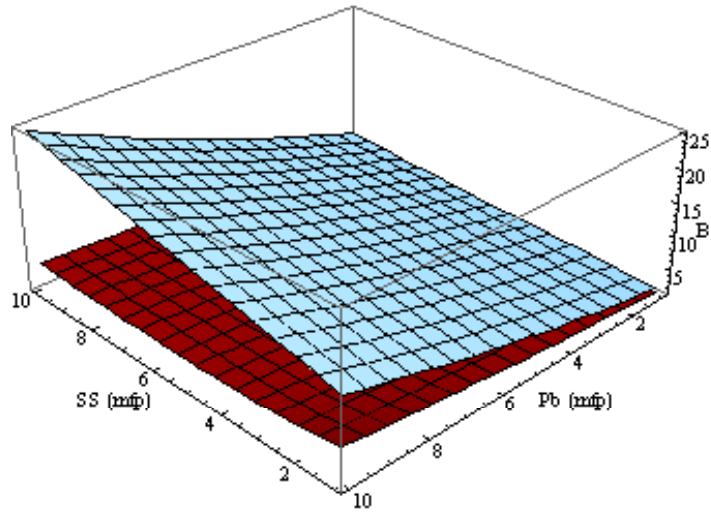

Figure 3.632 Exposure Buildup Factors for 500 keV photons incident on shields of stainless steel and lead of varying thicknesses. The blue surface is lead followed by stainless steel and the red is stainless steel followed by lead

3.64 Incident Photons of 1 MeV

Dose Buildup for Stainless Steel and Lead 1 MeV

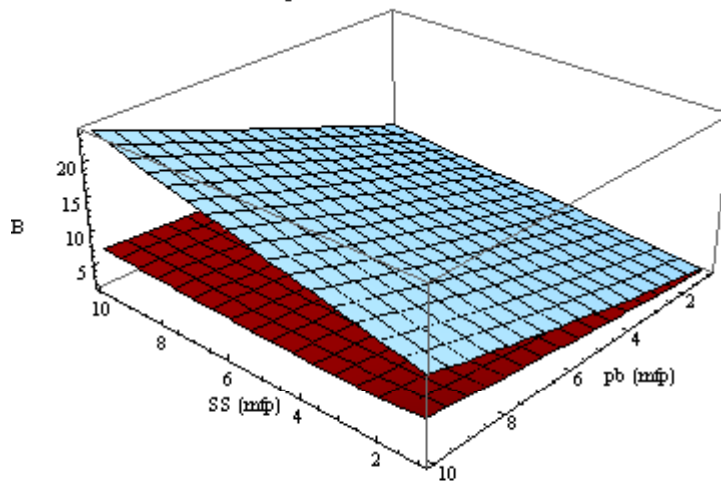

Figure 3.641 Dose Buildup Factors for 1 MeV photons incident on shields of stainless steel and lead of varying thicknesses. The blue surface is lead followed by stainless steel and the red is stainless steel followed by lead

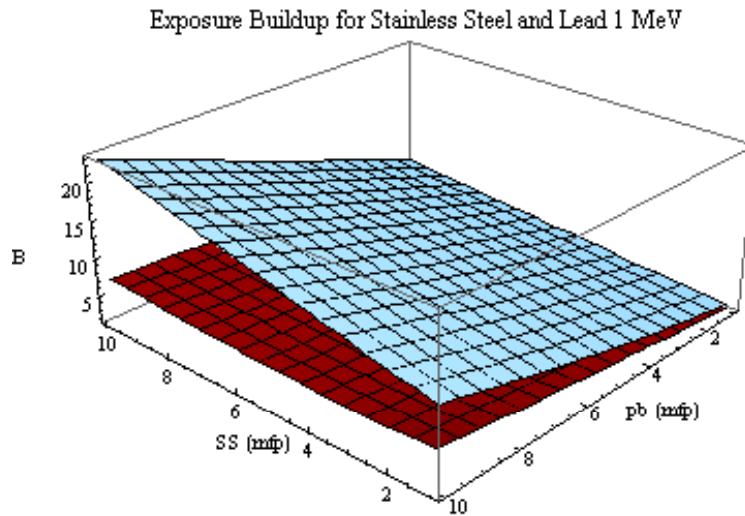

Figure 3.642 Exposure Buildup Factors for 1 MeV photons incident on shields of stainless steel and lead of varying thicknesses. The blue surface is lead followed by stainless steel and the red is stainless steel followed by lead

3.65 Incident Photons of 2 MeV

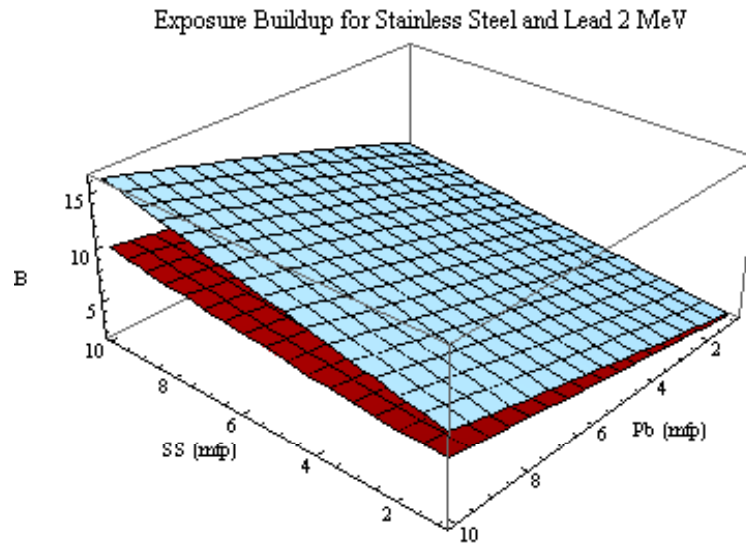

Figure 3.651 Dose Buildup Factors for 2 MeV photons incident on shields of stainless steel and lead of varying thicknesses. The blue surface is lead followed by stainless steel and the red is stainless steel followed by lead

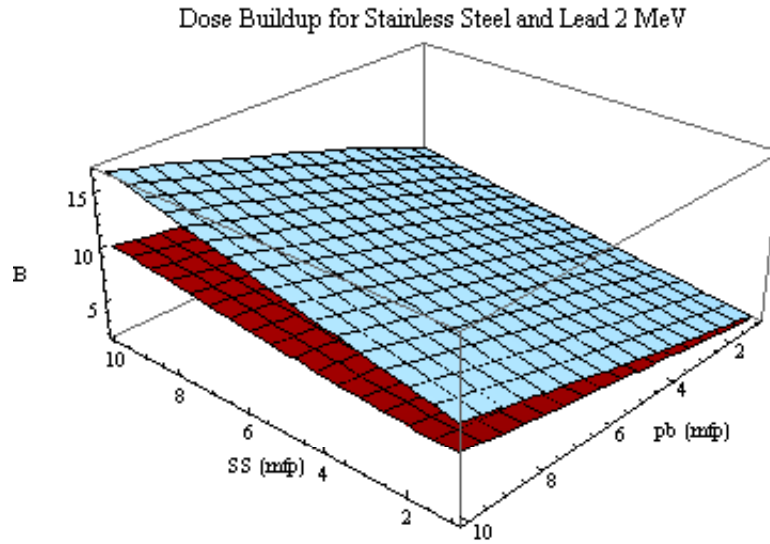

Figure 3.652 Exposure Buildup Factors for 2 MeV photons incident on shields of stainless steel and lead of varying thicknesses. The blue surface is lead followed by stainless steel and the red is stainless steel followed by lead

3.66 Incident Photons of 6 MeV

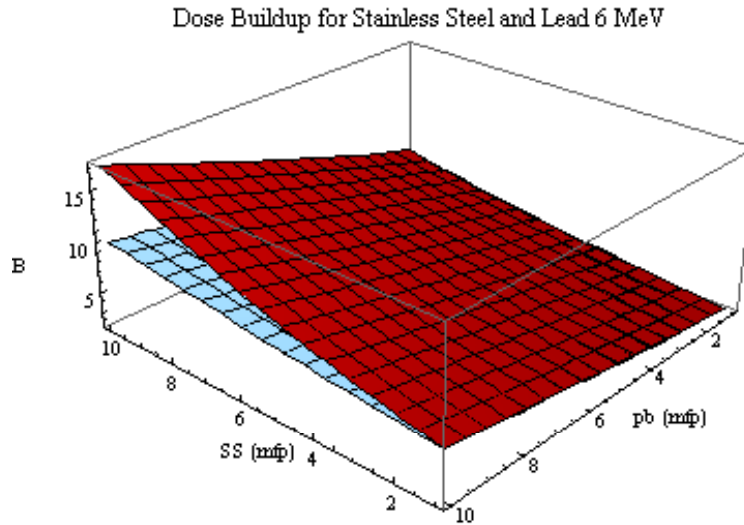

Figure 3.661 Dose Buildup Factors for 6 MeV photons incident on shields of stainless steel and lead of varying thicknesses. The blue surface is lead followed by stainless steel and the red is stainless steel followed by lead.

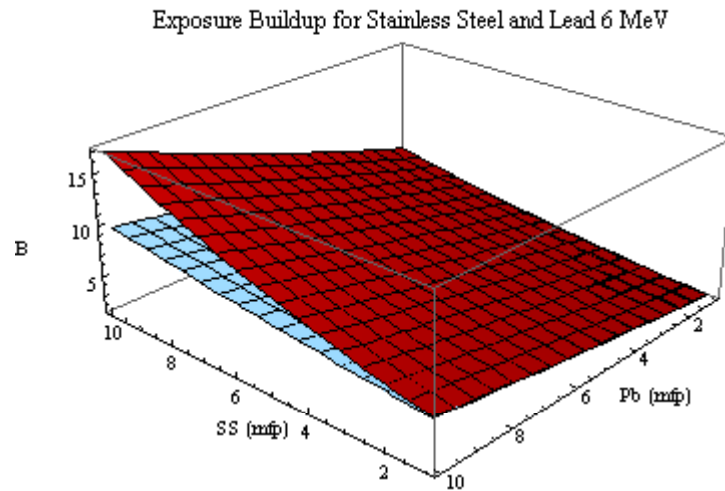

Figure 3.662 Exposure Buildup Factors for 6 MeV photons incident on shields of stainless steel and lead of varying thicknesses. The blue surface is lead followed by stainless steel and the red is stainless steel followed by lead.

3.67 Incident Photons of 10 MeV

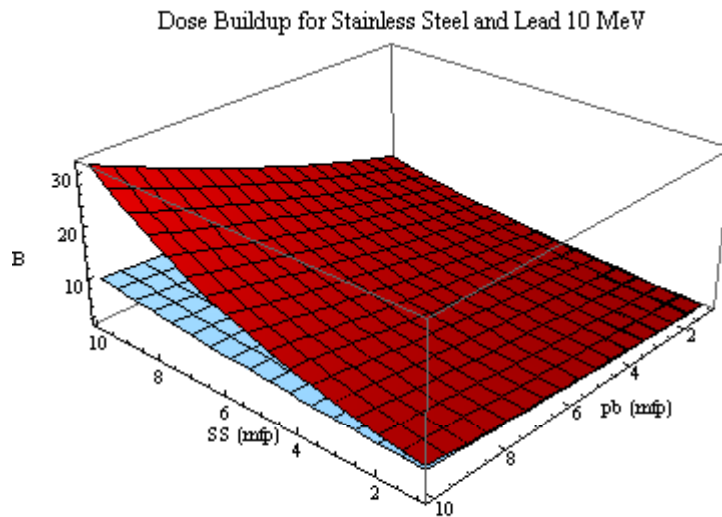

Figure 3.671 Dose Buildup Factors for 10 MeV photons incident on shields of stainless steel and lead of varying thicknesses. The blue surface is lead followed by stainless steel and the red is stainless steel followed by lead.

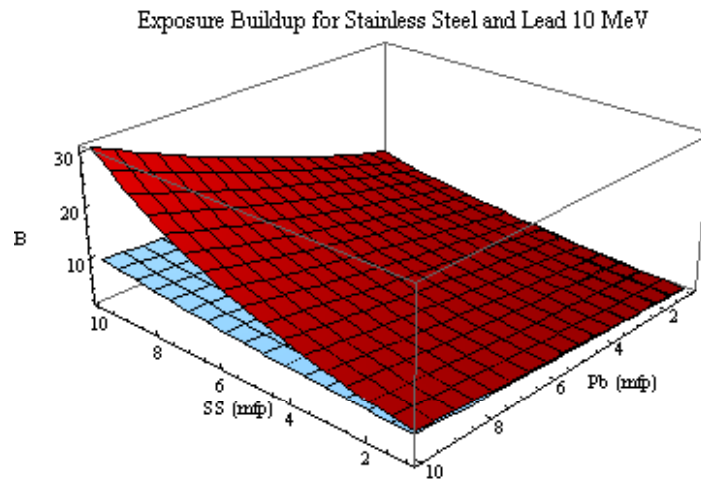

Figure 3.672 Exposure Buildup Factors for 10 MeV photons incident on shields of stainless steel and lead of varying thicknesses. The blue surface is lead followed by stainless steel and the red is stainless steel followed by lead.

CHAPTER 4

Benchmark Calculations

There are several different formulae for fractional difference used in this section. The absolute value of fractional difference is given by:

$$\frac{|B_{MCNP} - B_{PARTISN}|}{B_{MCNP}} \quad (4.1)$$

The pure fractional difference used in Figure 4.11, Tables 4.11 – 4.13 and Table 4.21 is given by:

$$\frac{B_{MCNP} - B_{PARTISN}}{B_{MCNP}} \quad (4.12)$$

And for reasons that will be explained in the appropriate section, the fractional difference used in Figure 4.12 is given by:

$$\frac{B_{MCNP} - B_{PARTISN}}{B_{PARTISN}} \quad (4.13)$$

4.1 Thin Shield Benchmarks

As discussed in section 2.4, the PARTISN calculations performed in this analysis were benchmarked using MCNP5. The energy-group averaging effects of the discrete-ordinates method were approximated in MCNP5 by randomly sampling source energies across the energy bin corresponding to the source group in PARTISN. This also allowed the physical thicknesses used in the PARTISN calculations to also be used in the MCNP5 calculations. Due to the thicknesses of the shields and the complexity of variance reduction

techniques required to reduce the computation time for a thick shield problem to a reasonable length, all the PARTISN calculations were not repeated in MCNP5. Thin shield benchmark calculations were made for 2 mfp shields of all configurations for the following energies: 65 keV, 1 MeV, and 10 MeV. These are represented in Figure 4.11 which shows the absolute fractional differences between the PARTISN dose calculations and the MCNP5 benchmark dose calculations:

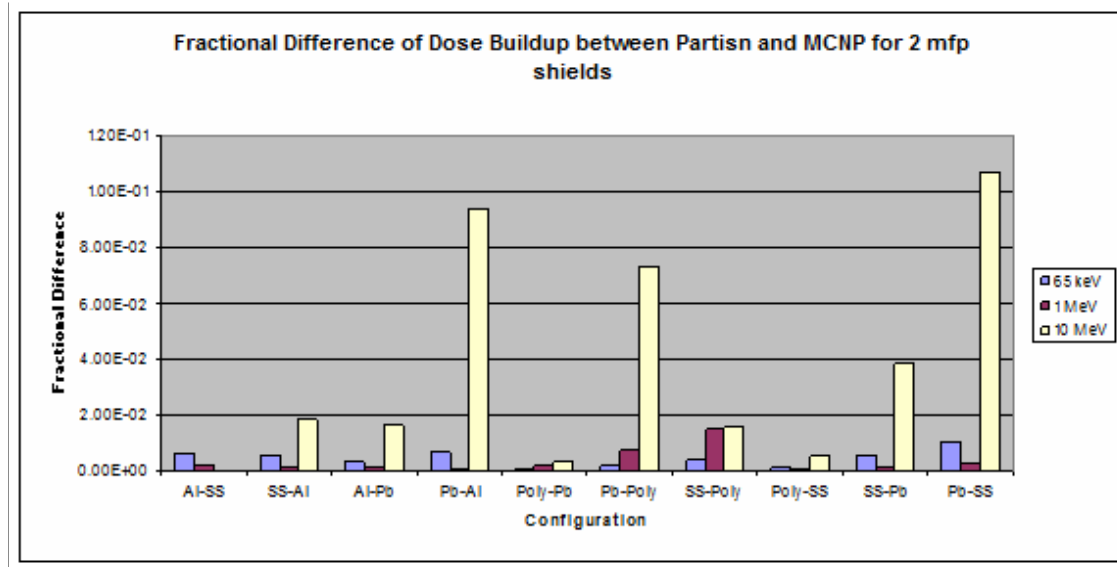

Figure 4.11 Absolute fractional differences between PARTISN flux calculations and MCNP5 Flux Calculations.

The following tables give the numerical values for the benchmark calculations. The tables give the pure fractional differences for flux, dose and exposure:

Table 4.11 Fractional Difference Between PARTISN and MCNP5 Flux Calculations

2 mfp	65	1	10
Al-SS	6.22E-03	4.33E-03	3.66E-02
SS-Al	5.21E-03	5.25E-03	6.93E-02
Al-Pb	4.23E-03	6.75E-03	9.31E-02
Pb-Al	6.37E-03	9.98E-03	2.02E-01
Poly-Pb	-5.81E-04	8.09E-03	7.54E-02
Pb-Poly	1.93E-03	9.18E-03	2.03E-01
SS-Poly	8.90E-04	5.14E-03	7.02E-02
Poly-SS	2.07E-03	5.91E-03	2.03E-02
SS-Pb	5.23E-03	7.38E-03	1.21E-01
Pb-SS	1.01E-02	1.23E-02	2.10E-01

Table 4.12 Fractional Difference Between PARTISN and MCNP5 Dose Calculations

	2 mfp	65	1	10
Al-SS	5.96E-03	-2.15E-03	-2.90E-05	
SS-Al	5.29E-03	-1.16E-03	1.88E-02	
Al-Pb	3.52E-03	1.10E-03	1.65E-02	
Pb-Al	6.55E-03	3.69E-04	9.38E-02	
Poly-Pb	-9.81E-04	2.25E-03	3.25E-03	
Pb-Poly	-2.17E-03	-7.29E-03	7.34E-02	
SS-Poly	-3.87E-03	-1.48E-02	1.58E-02	
Poly-SS	1.63E-03	-7.61E-04	-5.61E-03	
SS-Pb	5.45E-03	1.39E-03	3.86E-02	
Pb-SS	9.98E-03	3.08E-03	1.07E-01	

Table 4.13 Fractional Difference Between PARTISN and MCNP5 Exposure Calculations

	2 mfp	65	1	10
Al-SS	5.47E-02	-2.97E-03	-1.50E-03	
SS-Al	5.63E-03	-2.51E-03	1.64E-02	
Al-Pb	-2.90E-02	-4.51E-04	1.40E-02	
Pb-Al	7.20E-03	-1.43E-03	8.91E-02	
Poly-Pb	-3.79E-02	8.17E-04	1.00E-03	
Pb-Poly	-4.70E-03	-7.06E-03	7.14E-02	
SS-Poly	-6.71E-03	-1.36E-02	1.59E-02	
Poly-SS	5.69E-02	-1.38E-03	-6.64E-03	
SS-Pb	-6.49E-02	1.51E-04	3.54E-02	
Pb-SS	5.67E-02	2.21E-03	1.03E-01	

In comparing table 4.11 to tables 4.12 and 4.13, it is obvious that there are much higher percent differences in the flux calculations than in the exposure and dose calculations. This is because of the statistical nature of the MCNP5 calculation. At low energies, and in particularly narrow energy bins, there will be large relative errors and low weight photons making the fluxes reported in these ranges unreliable. This effect has only minor effect on dose as the dose response function is not affected by these low weight particles. Exposure, on the other hand, is increasing at low energies, so it is somewhat more affected by low weight, low energy particles, but it is only minimally affected by low weight particles at other energies.

One major consequence of this effect is in the relatively high percent differences in dose at 10 MeV for shields beginning with a high-Z material. This raises the question of which calculation is more accurate. Our best tool for analyzing the reliability of the MCNP results is the relative standard deviation in each energy bin. For 10 MeV photons incident on a shield of lead and stainless steel, the dominant effect will be pair production. This will eventually lead to the production of 0.511 MeV annihilation photons, many of which will experience slight Compton scattering before being absorbed due to the photoelectric effect. Very few photons will experience sufficient Compton scattering to reach the lowest energy bins (~ 1 keV). Therefore, much of the response will be due to virgin source-energy photons and from (quasi-) virgin 0.511 keV annihilation photons. For the Monte-Carlo method, the fewer particles tallied in an energy bin the worse the relative standard deviation. Thus, in this case, since few low energy particles are completely transported through the shield, the relative standard deviation in the MCNP5 calculations will be very high and thus the calculations will be unreliable. Of all the cases in this research, shields of lead followed by stainless steel show this most dramatically as they are the two materials with the highest absorption cross sections. For 10 MeV photons incident on a 2mfp Shield of lead followed by stainless steel, the following plot shows the fractional difference between the MCNP5 dose calculations and the PARTISN calculations:

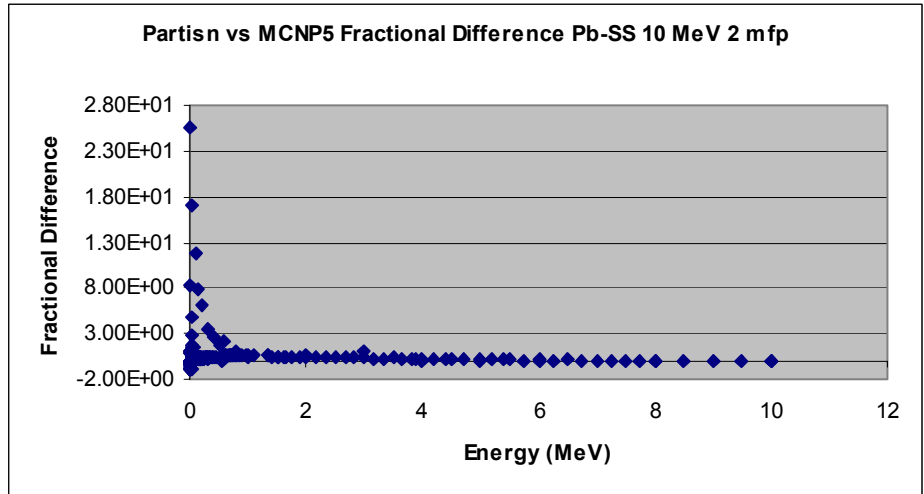

Figure 4.12 PARTISN vs. MCNP5 Fractional Difference for 10 MeV photons incident on a 2-mfp shield of lead followed by stainless steel. Notice the high fractional difference at low energies negative values represent values where MCNP5 dose is higher than PARTISN dose.

It is clear from figure 4.12 that the MCNP5 dose responses at low energies are much higher than the PARTISN dose responses. The percent difference used in figure 4.12 is given by equation 4.13. Equation 4.13 was used due to the lack of confidence in the MCNP5 calculations in the relevant energy bins.

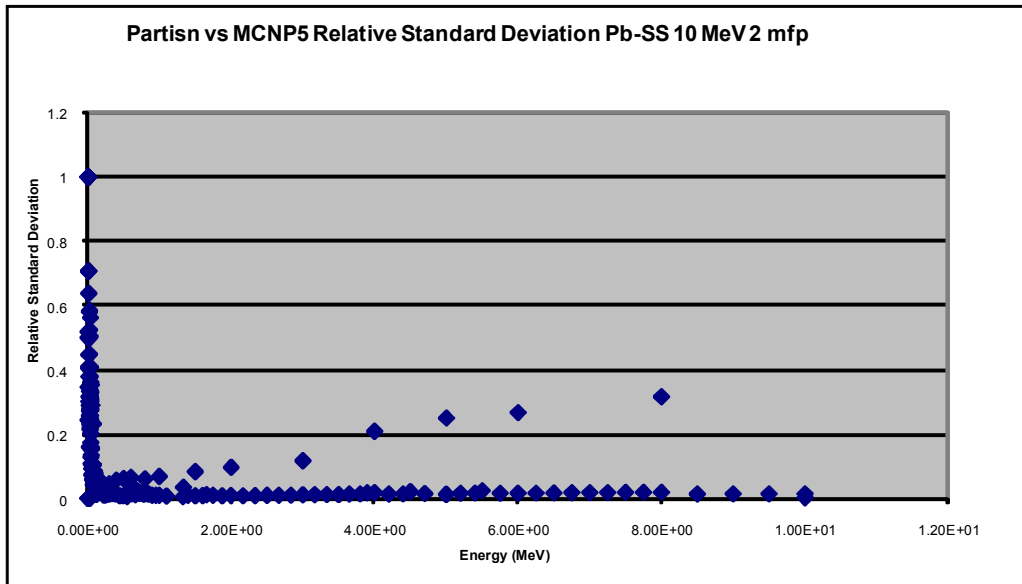

Figure 4.13 MCNP5 Relative Standard Deviation for Dose calculation of 10 MeV Photons incident on a 2mfp shield of lead followed by stainless steel. The x- axis shows Energy in MeV. The y-axis shows relative standard deviation.

The relative standard deviations are highest in the narrowest bins (which were designed as “source groups” for discrete ordinates calculations; these are the spikes in figure 4.13) and at low energies where few particles will be transported.

Referring back to Figure 4.11 we see that the fractional difference for 10 MeV incident photons is slightly better for shields ending in materials with higher absorption cross sections. This is because the low energy photons are more likely to be absorbed, as are the annihilation photons so they do not appear in the response calculation.

Though an 11% difference is not an alarming difference between a discrete ordinates and a Monte-Carlo method, the difference is explainable and could perhaps be reduced by several percent by use of weight windows in the MCNP5 calculation to remove the low weight particles. Thus, even in the worst case these benchmarking calculations bolster confidence in the present research. A sample MCNP5 Input File is given in Appendix 14.

4.2 Thick Shield Benchmarking

For thick shield calculations, MCNP5 requires variance reduction techniques to perform the calculations in a reasonable length of time. The technique used was to divide the shields into 1-mfp thick cells and increase the cell importance by a factor of three at each cell boundary. Using this technique, calculations were performed for 10- and 20-mfp shields. The results are presented in the following table:

Table 4.21 Benchmark values for representative thick shields. The cases of 5 mfp of aluminum followed by 5 mfp of lead and of 10 mfp of polyethylene followed by 10 mfp of lead are presented.

10 mfp (Al-Pb) 65 keV 5 x 5			
	Flux	Dose	Exposure
PARTISN	1.31E-04	6.74E-05	2.91E-07
MCNP5	1.26E-04	6.52E-05	2.70E-07
Fractional Difference	-3.97E-02	-3.37E-02	-7.78E-02
20 mfp (Poly-Pb) 65 keV 10 x 10			
	Flux	Dose	Exposure
PARTISN	9.38E-09	4.84E-09	2.09E-11
MCNP5	9.22E-09	4.75E-09	1.97E-11
Fractional Difference	-1.71E-02	-1.86E-02	-5.74E-02

Table 4.21 shows the excellent agreement between MCNP5 and PARTISN. An example MCNP5 input file for this variance reduction technique is given in Appendix 15.

CHAPTER 5

Analytical Fit

The parameters for the analytical fit described in Section 2.5 are listed in appendices 4 and 5. Each Table represents a particular configuration of 2 materials for all 7 representative energies for a particular response.

The analytical fit formula, as described earlier, is given by:

$$B(x,y) = \frac{a + bx + cy^2}{f + dx + ex^2 + gy + hy^2} \quad (5.10)$$

In general, the fits are good. For most cases it is possible to use one of the three methods outlined in section 2.5 to obtain buildup factors less with less than 10% fractional difference from those calculated in this work. For most cases the fractional difference never exceeds 15% and for many is less than 8%. The worst case is for shields involving lead with incident photons around 100 keV. Then the log fits produces buildup factors with fractional differences as high as 30%. Appendices 6 and 7 provide point by point fractional differences for each thickness, energy and configuration. Appendices 8 and 9 provide general statistical checks such as standard deviation, maximum, minimum and average fractional difference.

Parameter tables for dose and exposure responses are grouped together for easy reference.

5.1 Comparison with Guvendik

The shielding configurations presented in this work are not represented in previous studies of buildup factors in stratified shields. For a low- Z material, the common option is water as opposed to polyethylene. In the work of Guvendik and Tsoufanidis, the materials examined are Water, Concrete, Iron and lead. Since the Guvendik formula is only valid for 10 or less mean free paths, the low second material formula was used. The following figures are plots of the absolute fractional differences between the simple Guvendik formulae from chapter 2:

$$B(E, x, y) = \frac{a + bE + cx + dy}{1 + fE + gx + hy} \quad (5.11)$$

and the PARTISN buildup factors from this work co-plotted with the fractional differences between the formulae presented in this work and the same PARTISN buildup factors.

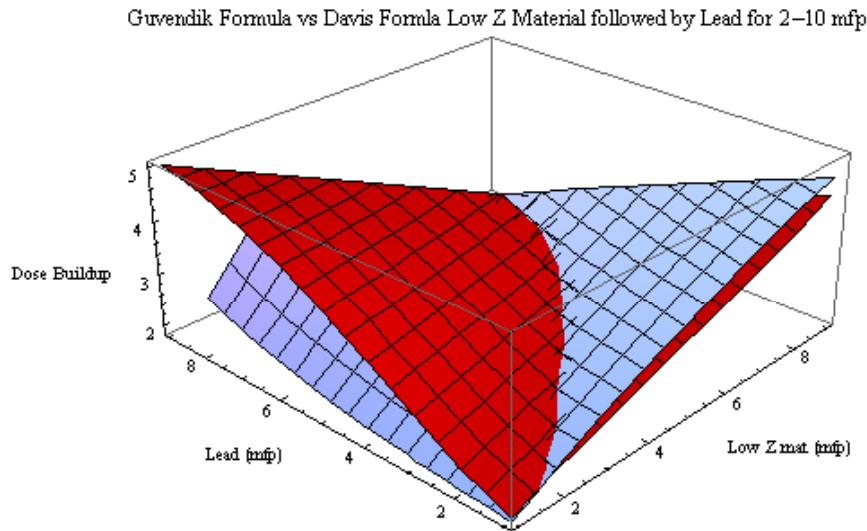

Figure 5.11 Plot of Guvendik formula (blue surface) for dose buildup at 1 MeV for water followed by lead vs. Davis formula (red surface) for dose buildup at 1 MeV for polyethylene followed by lead

Guvendik Formula vs Davis Formula Low Z Material followed by High Intermediate Z Material for 2–10 mfp

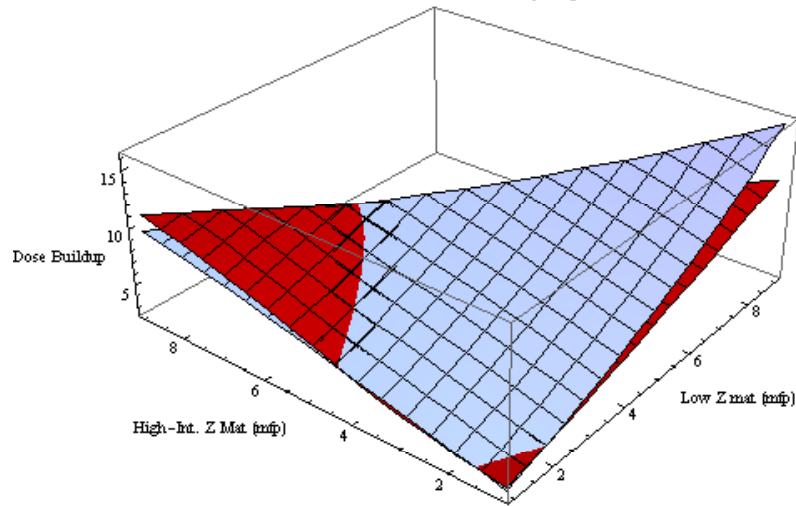

Figure 5.12 Plot of Guvendik formula (blue surface) for dose buildup at 1 MeV for water followed by iron vs. Davis formula (red surface) for dose buildup at 1 MeV for polyethylene followed by iron.

Given that these formulae each fit configurations of different materials; this qualitative comparison is presented only as a rough comparison between the present formula and the most similar previous formula.

5.2 Comparison with Dudziak Weighted-Mean Method

Many of the formulae, or recipes, developed for buildup in stratified shields involve combinations of previously calculated buildup factors. Some examples of these include the method of Kalos [4] which, though it is widely accepted as the most accurate empirical formula for buildup in stratified shields, only deals with shields of water and lead with each layer being 3 mfp (or less) thick. The method of Broder, Kayurin and Kutrezov [6] was developed for the same configuration as that of Kalos. Harima [8] developed a formula for stratified shields of combinations of water, lead and iron. The Dudziak weighted mean

formula [20] is a general approximation for buildup in stratified shields and has the following form:

$$B_t = \frac{\sum_i b_i B_i(b_i)}{\sum_i b_i} \quad (5.21)$$

where i represents the layer, b_i is the optical thickness of the i^{th} layer and $B(b_i)$ is the single-layer Buildup for the i^{th} layer of thickness b_i . In order to compare this formula with the present formula, the normal incidence buildup factors developed by Schirmers [15] were used. The buildup calculated from equation (5.21) was then compared to the buildup values developed in this work for dual-layer shields by calculating the absolute percent difference between them. The fractional difference was used in order to present the results in convenient graphical form. These were then co-plotted with the absolute fractional differences between the formula and buildup factors developed by this work. These are shown in figure 5.12.

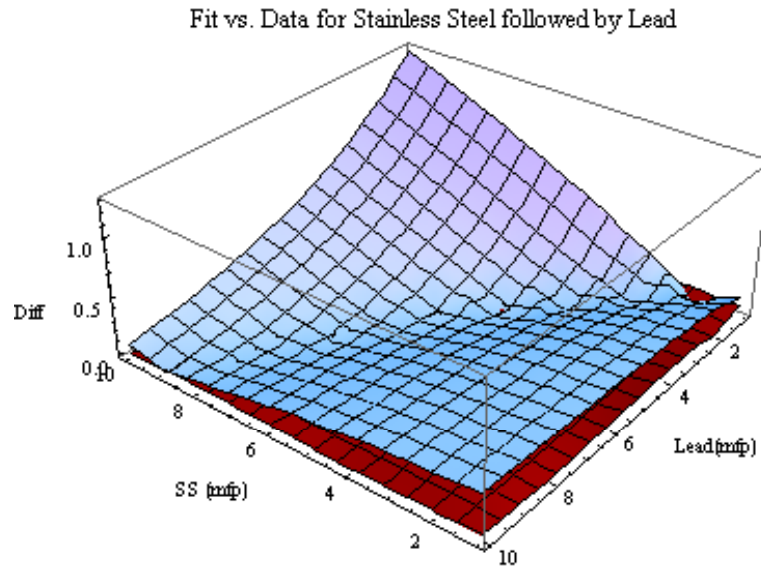

Figure 5.21 Plot of fractional difference between Dose Buildup Data for 1 MeV and the Dudziak weighted mean formula (blue surface) vs. the same for the present fit formula (red surface) for dose buildup for stainless steel followed by lead at 1 MeV. The Single-layer Buildup factors used in the Dudziak weighted mean formula were from Schirmers [15].

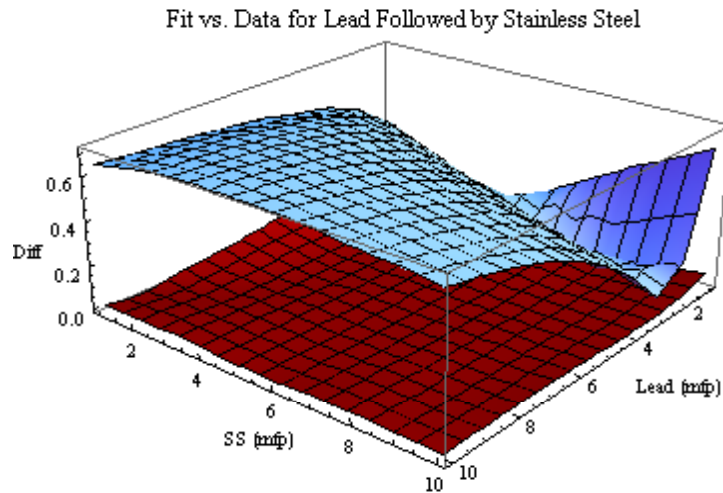

Figure 5.22 Plot of fractional difference between dose buildup data for 1 MeV and the Dudziak weighted mean formula (blue surface) vs. the same for the present fit formula (red surface) for dose buildup for lead followed by stainless steel at 1 MeV. The single-layer buildup factors used in the Dudziak weighted mean formula were from Schirmers [15].

The figures show that for both configurations, the present formula gives a much better overall fit.

5.3. Comparison with Multiplicative Formula

Recall equation 1.21:

$$B_{tot} = B_1(b_1) \times B_2(b_2)$$

where

B_n = Buildup Factor for material n

b_i = optical thickness of material n

This is another general approximation for buildup in stratified shields. Again, using the Schirmers [15] buildup factors, figure 5.31 shows the fractional difference between

buildup factors calculated from equation 1.21 and the buildup factors calculated in this research (blue surface). These were then co-plotted with the absolute fractional differences between the formula and buildup factors developed by this work.

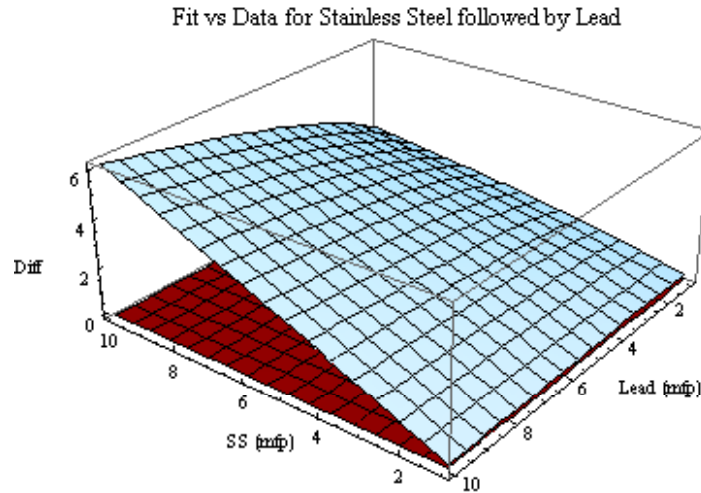

Figure 5.31 Plot of fractional difference between Dose Buildup Data and the multiplicative formula (blue surface) vs. the same for the present formula (red surface) for dose buildup for stainless steel Followed by lead. The Single-layer Buildup factors used in the multiplicative formula were from Schirmers [15].

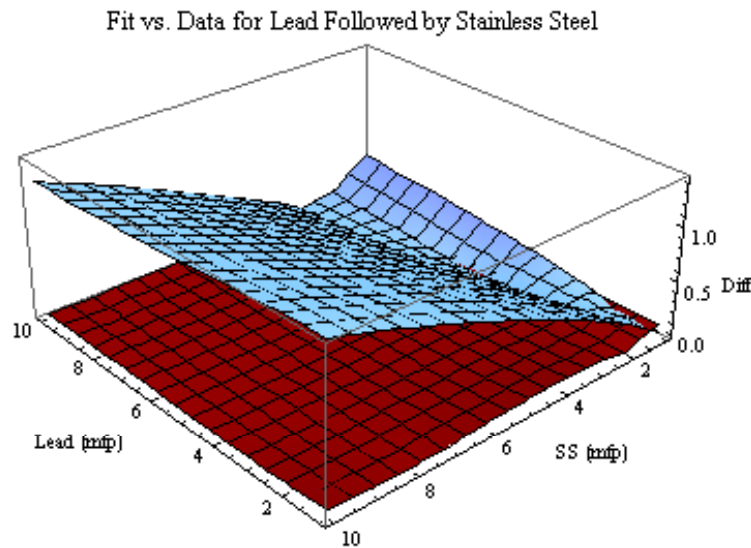

Figure 5.32 Plot of fractional difference between Dose Buildup Data and the multiplicative formula (blue surface) vs. the same for the present formula (red surface) for dose buildup for lead followed by stainless steel. The single-layer buildup factors used in the multiplicative formula were from Schirmers [15].

Though the multiplicative formula is somewhat better for the case of lead followed by stainless steel, in neither case is it as accurate as the present formula. Both the multiplicative and the Dudziak weighted mean formulae are independent of material order. When comparing the preceding plots of fractional difference for stainless steel and lead, it is clear that for certain configurations these formulae are more accurate than for other configurations. It is worth noting that the Dudziak weighted-mean formula is considerably more accurate than the multiplicative formula, as seen in comparison of the preceding plots.

A detailed study of the accuracy of these formulae (Equations 1.21 and 5.21) with respect to material order is beyond the scope of this research.

CHAPTER 6

Conclusion

This research has developed photon buildup factors for photons normally incident on dual-layer shields of several representative energies of interest in nuclear engineering, especially in radiation protection. The dual-layer shields in this research were considerably thicker and composed of materials not usually examined in previous dual-layer buildup factor studies. Also, this work has provided not only tabular values of buildup factors and their analytical fit, but also a new method for the presentation of dual-layer buildup factors, the surface plot. The surface plot method not only illustrates the effect of thickness on buildup, but also allows easy comparison of different shielding configurations.

In most cases, for incident photons with energies low enough such that pair production is not a dominant process, buildup is higher for shields composed of a higher Z material followed by a lower Z material. There are several notable exceptions. Exposure buildup for 65 keV photons incident on stainless steel followed by lead is higher than the reverse case due to the shape of the exposure response function below this energy. Dose and exposure buildup for 100 keV photons incident on shields of aluminum and lead and stainless steel and lead are higher than their reverse cases because of the higher photoelectric cross-section about this energy and lower photoelectric cross section below the k-edge.

The biggest dependence on material order comes with aluminum and lead around 100 keV. Since Compton scattering is much more dominant in aluminum than in stainless steel and less dominant than in polyethylene, the buildup for aluminum followed by lead will be much higher than for stainless steel followed by lead and lower than for polyethylene followed by lead. However, the photoelectric effect is much more dominant in aluminum

than in polyethylene and slightly less dominant than in stainless steel; therefore, shields beginning with lead and ending in aluminum will have much lower buildup than for lead followed by polyethylene and only slightly higher buildup than for lead followed by stainless steel. Lead is used in these cases because its k-edge at 88 keV causes certain shields involving it to have the unusually high buildup, as discussed earlier.

Shields of aluminum and stainless steel for photons about 2 MeV showed the least dependence on material order. However, between the energies of 1.022 MeV and 10 MeV all configurations will show order independence as pair production begins to dominate. Thus in this range, order independence depends on the specific materials used and their pair production cross section. Another notable case exhibiting some degree of order independence is polyethylene and lead at 100 keV. Since polyethylene has a relatively small photoelectric cross section at 100 keV, photons that are Compton scattered below the k-edge for lead are less likely to be absorbed in lead. Thus, in the case of polyethylene followed by lead photons will Compton scatter below 88 keV, and then be transported through both layers. In the reverse case, photons will be lightly Compton scattered below the k-edge, be transported through the lead layer and then be transported through the polyethylene layer where they will experience mainly Compton scattering.

The analytical formula developed in this research is valid for two different response functions and depends only on the thicknesses of the layers. This is significantly more convenient and accurate than most previous formulae involving combinations of previously calculated buildup factors and represents more configurations, more energies and thicker shields than any previous analytical formula.

REFERENCES

1. G. R. White, "The penetration and Diffusion of Co⁶⁰ Gamma-Rays in Water Using Spherical Geometry," Phys Rev, 80v2 154 (1950)
2. Goldstein, H. and Wilkins, Jr., J.E., "Calculations of the Penetrations of Gamma rays," NDA/AEC Report NYO-3075 , US Government Printing Office, Washington, DC, (1954)
3. Shultis, J. K. and Faw, R.E., *Radiation Shielding*, Prentice Hall PTR, Upper Saddle River, NJ, 1996 p.215
4. Goldstein, H., *Fundamental Aspects of Reactor Shielding*, Addison Wesley, Reading, MA, 1959
5. Fano, U., L.V. Spencer, and M.J. Berger, "Penetration and Diffusion of X Rays", Handbuch der Physik, 38/2, S. Flüge (ed.), Springer –Verlag, Berlin, 1959 (From Shultis and Faw)
5. Harima, Y., "An Approximation of Gamma-Ray Buildup Factors by Modified Geometric Progression," Nucl. Sci. Eng., 83 299-309 1986
6. Broder, D.L., Yu. P. Kayurin, and A.A. Kutrezov, Sov. J. At. Energy, 12, 26-31 (1962) (from Shultis and Faw [3])
7. Bünemann, D. G. Richter, "Multilayered shields", Engineering Compendium on Radiation Shielding, Vol. I p 230 .G. Jaeger (ed.), Springer-Verlag, New York, 1968 Shultis and Faw
8. Y. Harima "An Approximation of Gamma-Ray Buildup Factors for Two Layer Shields," Nucl. Sci. Eng. 85 45-79 (1983)
9. Harima, Y., Y. Sakamoto, S. Tanaka, M. Kawai, "Validity of the Geometric Progression Gamma-Ray Buildup Factors", Nucl. Sci. Eng., 94 24-25 (1986)
10. Melvut Guvendik, Nicholas Tsoulfanidis, "Formulas Giving Buildup Factor For Double-Layered Shields", Nucl. Tech. 131 332-336 (2000)
11. Wooten, H.O., Dudziak, D.J., Hertel, N.E., Kornreich, D.E., "A Time-Dependent Dose Model for Glovebox Processing of Fissile Material" Rad. Prot. Dosim., 115, No.1-4, 350-356, (2005)
12. Kornreich, D., Dooley, D., "PANDEMONIUM: Bringing Order to Dose in Complicated Glovebox Arrays," LA-UR-99-2765, Los Alamos National Laboratory, 1999.
13. Duderstadt, James J. Transport Theory John Wiley & Sons Inc, New York p.1 (1979)

14. Bell, G. and Glasstone, S., Nuclear Reactor Theory, Van Nostrand Reinhold Company, New York, NY, (1970) p.1
15. Schirmers, Fritz Gordon, “Improvement of Photon Buildup Factors for Radiological Assessment” North Carolina State University, (2006)
16. Wooten, H. Omar, “Time Dependent Neutron and Photon Dose Field Analysis”, Georgia Institute of Technology, (2005)
17. Cullen, D., Hubbell, J., Kissel, L., “EPDL97: The Evaluated Photon Data Library, '97 Version,” UCRL-50400 Vol. 6 Rev. 5, University of California, 1997.
18. MacFarlane, R., Muir, D., “The NJOY Nuclear Data Processing System, Version 91,” LA-12740-M, Los Alamos National Laboratory, 1994.
19. Wooten, H. Omar, “Improvements to the CEPXS Code for Generating Coupled Photon/Electron Multi-group Cross Sections” LA-UR-06-2893 Los Alamos National Laboratory, 2006
20. Dudziak, Donald J., The Dudziak weighted-mean formula was transmitted in personal communication as taught at the Bettis Reactor Engineering School. June 2007.
21. L.P. Ekström and R.B. Firestone, WWW Table of Radioactive Isotopes, database version 2/28/99 from URL <http://ie.lbl.gov/toi/index.htm>

APPENDICES

Appendix 1: Dose Buildup

The following tables present the Buildup factors calculated in PARTISN for various materials and energies. In each table, the first material thicknesses increase along the rows, the second material thicknesses increase along columns. For example, column 2 shows fractional differences for shields with 2 mfp of the first material followed by 1-10 mfp of the second material.

Aluminum followed by lead
Al-Pb 65 keV Dose Buildup Factors

Dose	1	2	3	4	5	6	7	8	9	10
1	1.471	1.495	1.555	1.627	1.706	1.787	1.870	1.955	2.041	2.129
2	1.845	1.802	1.831	1.887	1.955	2.030	2.110	2.192	2.278	2.365
3	2.251	2.139	2.136	2.174	2.230	2.298	2.373	2.453	2.536	2.623
4	2.696	2.511	2.473	2.490	2.534	2.593	2.663	2.739	2.820	2.907
5	3.185	2.921	2.844	2.837	2.867	2.917	2.980	3.053	3.132	3.217
6	3.725	3.373	3.252	3.220	3.233	3.272	3.329	3.396	3.474	3.557
7	4.322	3.875	3.706	3.647	3.643	3.656	3.706	3.770	3.845	3.928
8	4.979	4.424	4.201	4.109	4.085	4.083	4.124	4.182	4.253	4.335
9	5.703	5.029	4.746	4.618	4.570	4.551	4.582	4.634	4.701	4.780
10	6.501	5.694	5.344	5.176	5.103	5.064	5.084	5.128	5.191	5.268

Al-Pb 100 keV Dose Buildup Factors

Dose	1	2	3	4	5	6	7	8	9	10
1	2.803	3.576	4.658	6.246	8.649	12.390	18.358	28.072	44.164	71.235
2	3.980	4.994	6.515	8.846	12.490	18.318	27.828	43.618	70.247	115.762
3	5.316	6.654	8.745	12.043	17.312	25.895	40.121	64.070	104.950	175.584
4	6.832	8.572	11.364	15.850	23.128	35.136	55.258	89.458	148.331	250.813
5	8.545	10.761	14.380	20.266	30.041	46.183	73.442	120.087	200.857	342.184
6	10.485	13.263	17.863	25.415	38.057	59.088	94.819	156.289	263.224	451.102
7	12.670	16.101	21.836	31.326	47.308	74.051	119.705	198.572	336.277	578.998
8	15.122	19.303	26.344	38.067	57.905	91.256	148.412	247.481	420.974	727.578
9	17.866	22.902	31.434	45.710	69.965	110.900	181.278	303.607	518.358	898.705
10	20.928	26.934	37.160	54.340	83.625	133.211	218.693	367.626	629.625	1094.500

Al-Pb 500 keV Dose Buildup Factors

Dose	1	2	3	4	5	6	7	8	9	10
1	1.658	1.811	1.984	2.163	2.347	2.534	2.725	2.921	3.120	3.323
2	2.067	2.126	2.249	2.397	2.559	2.729	2.907	3.091	3.281	3.475
3	2.494	2.451	2.522	2.637	2.775	2.929	3.092	3.265	3.444	3.630
4	2.942	2.788	2.804	2.884	2.998	3.133	3.281	3.441	3.610	3.786
5	3.413	3.138	3.094	3.137	3.225	3.341	3.474	3.621	3.779	3.945
6	3.909	3.502	3.394	3.398	3.458	3.553	3.669	3.803	3.950	4.107
7	4.430	3.879	3.703	3.665	3.696	3.769	3.869	3.989	4.124	4.270
8	4.977	4.272	4.022	3.939	3.940	3.990	4.073	4.178	4.301	4.437
9	5.550	4.678	4.351	4.221	4.190	4.216	4.280	4.371	4.480	4.606
10	6.150	5.100	4.690	4.510	4.445	4.447	4.492	4.566	4.663	4.777

Al-Pb 1 MeV Dose Buildup Factors

Dose	1	2	3	4	5	6	7	8	9	10
1	1.857	2.167	2.479	2.790	3.102	3.416	3.732	4.052	4.376	4.704
2	2.349	2.586	2.859	3.145	3.440	3.741	4.048	4.360	4.677	4.998
3	2.855	3.014	3.246	3.506	3.783	4.070	4.366	4.670	4.979	5.294
4	3.376	3.452	3.641	3.874	4.130	4.403	4.687	4.981	5.283	5.591
5	3.915	3.902	4.044	4.247	4.482	4.739	5.012	5.295	5.588	5.889
6	4.471	4.362	4.454	4.625	4.839	5.079	5.338	5.611	5.894	6.188
7	5.044	4.832	4.872	5.009	5.199	5.422	5.667	5.928	6.202	6.487
8	5.634	5.312	5.296	5.398	5.563	5.767	5.997	6.246	6.510	6.786
9	6.239	5.802	5.727	5.792	5.931	6.115	6.329	6.566	6.819	7.086
10	6.859	6.302	6.165	6.191	6.302	6.465	6.664	6.886	7.129	7.386

Al-Pb 2 MeV Dose Buildup Factors

Dose	1	2	3	4	5	6	7	8	9	10
1	1.937	2.334	2.733	3.136	3.545	3.960	4.381	4.809	5.243	5.684
2	2.467	2.836	3.224	3.624	4.032	4.448	4.871	5.302	5.739	6.183
3	3.001	3.342	3.720	4.115	4.522	4.939	5.363	5.796	6.235	6.681
4	3.541	3.854	4.220	4.610	5.015	5.431	5.857	6.290	6.731	7.179
5	4.088	4.370	4.723	5.107	5.510	5.925	6.350	6.785	7.226	7.675
6	4.640	4.889	5.229	5.606	6.005	6.419	6.843	7.278	7.720	8.169
7	5.196	5.412	5.737	6.106	6.501	6.912	7.335	7.769	8.211	8.660
8	5.757	5.937	6.245	6.606	6.996	7.404	7.825	8.258	8.699	9.148
9	6.320	6.463	6.754	7.105	7.489	7.894	8.313	8.744	9.183	9.632
10	6.885	6.989	7.262	7.603	7.981	8.381	8.797	9.228	9.663	10.111

Al-Pb 6 MeV Dose Buildup Factors

Dose	1	2	3	4	5	6	7	8	9	10
1	1.830	2.174	2.542	2.943	3.382	3.863	4.391	4.971	5.608	6.308
2	2.311	2.703	3.130	3.597	4.109	4.670	5.285	5.962	6.705	7.521
3	2.780	3.226	3.714	4.248	4.834	5.476	6.181	6.955	7.805	8.738
4	3.242	3.743	4.292	4.895	5.556	6.280	7.075	7.947	8.904	9.954
5	3.698	4.255	4.867	5.538	6.273	7.080	7.964	8.934	9.998	11.166
6	4.149	4.761	5.436	6.175	6.985	7.873	8.847	9.916	11.083	12.368
7	4.594	5.262	5.999	6.807	7.688	8.658	9.721	10.887	12.160	13.561
8	5.035	5.758	6.553	7.428	8.386	9.436	10.583	11.845	13.227	14.743
9	5.468	6.246	7.101	8.042	9.073	10.203	11.441	12.792	14.279	15.907
10	5.895	6.726	7.641	8.647	9.749	10.957	12.281	13.726	15.314	17.055

Al-Pb 10 MeV Dose Buildup Factors

Dose	1	2	3	4	5	6	7	8	9	10
1	1.841	2.244	2.692	3.208	3.810	4.552	5.403	6.413	7.618	9.059
2	2.259	2.741	3.286	3.920	4.665	5.546	6.644	7.907	9.417	11.227
3	2.661	3.225	3.870	4.623	5.512	6.566	7.823	9.325	11.216	13.400
4	3.055	3.703	4.447	5.321	6.353	7.582	9.049	10.806	12.914	15.448
5	3.443	4.176	5.020	6.013	7.190	8.593	10.271	12.283	14.700	17.610
6	3.827	4.643	5.589	6.700	8.021	9.597	11.489	13.756	16.481	19.764
7	4.207	5.106	6.152	7.383	8.847	10.596	12.699	15.220	18.255	21.912
8	4.584	5.565	6.710	8.059	9.666	11.588	13.901	16.675	20.017	24.047
9	4.956	6.019	7.262	8.729	10.477	12.571	15.092	18.118	21.766	26.167
10	5.323	6.468	7.808	9.391	11.281	13.545	16.273	19.549	23.500	28.270

Lead Followed by Aluminum

Pb-Al 65 keV Dose Buildup Factors

Dose	1	2	3	4	5	6	7	8	9	10
1	1.897	2.593	3.311	4.083	4.925	5.850	6.870	7.994	9.235	10.603
2	2.042	2.775	3.530	4.339	5.221	6.189	7.254	8.428	9.721	11.147
3	2.182	2.953	3.746	4.593	5.515	6.526	7.637	8.860	10.208	11.692
4	2.320	3.131	3.961	4.847	5.810	6.864	8.022	9.295	10.696	12.239
5	2.458	3.308	4.176	5.101	6.105	7.203	8.407	9.731	11.187	12.789
6	2.596	3.485	4.391	5.356	6.401	7.543	8.794	10.169	11.680	13.342
7	2.733	3.663	4.608	5.612	6.699	7.885	9.185	10.610	12.178	13.900
8	2.871	3.841	4.825	5.870	6.999	8.230	9.577	11.055	12.679	14.462
9	3.010	4.021	5.044	6.130	7.301	8.577	9.974	11.504	13.185	15.030
10	3.150	4.201	5.265	6.391	7.606	8.928	10.373	11.957	13.695	15.603

Pb-Al 100 keV Dose Buildup Factors

Dose	1	2	3	4	5	6	7	8	9	10
1	2.374	3.413	4.568	5.868	7.334	8.989	10.849	12.937	15.270	17.873
2	2.962	3.954	5.078	6.357	7.812	9.462	11.325	13.421	15.769	18.392
3	3.783	4.728	5.808	7.053	8.482	10.114	11.967	14.060	16.411	19.043
4	4.992	5.890	6.913	8.104	9.488	11.083	12.908	14.980	17.318	19.945
5	6.834	7.698	8.649	9.763	11.075	12.606	14.375	16.402	18.703	21.302
6	9.722	10.590	11.457	12.465	13.669	15.097	16.773	18.716	20.944	23.479
7	14.357	15.316	16.101	16.972	18.021	19.294	20.821	22.624	24.724	27.141
8	21.936	23.174	23.919	24.628	25.468	26.515	27.814	29.395	31.280	33.495
9	34.531	36.437	37.266	37.820	38.395	39.127	40.088	41.325	42.867	44.744
10	55.758	59.111	60.332	60.821	61.100	61.414	61.890	62.606	63.607	64.937

Pb-AI 500 keV Dose Buildup Factors

Dose	1	2	3	4	5	6	7	8	9	10
1	2.389	3.598	4.961	6.498	8.218	10.128	12.233	14.538	17.043	19.754
2	2.783	4.128	5.637	7.330	9.215	11.300	13.590	16.089	18.798	21.721
3	3.148	4.632	6.288	8.136	10.189	12.451	14.929	17.624	20.541	23.680
4	3.503	5.125	6.928	8.935	11.157	13.598	16.266	19.162	22.289	25.649
5	3.853	5.615	7.568	9.735	12.128	14.752	17.612	20.712	24.053	27.637
6	4.203	6.107	8.212	10.541	13.107	15.917	18.974	22.280	25.839	29.651
7	4.555	6.603	8.861	11.356	14.099	17.096	20.353	23.871	27.650	31.695
8	4.911	7.105	9.520	12.182	15.104	18.293	21.753	25.486	29.492	33.774
9	5.271	7.615	10.188	13.020	16.125	19.509	23.176	27.128	31.365	35.887
10	5.637	8.132	10.867	13.872	17.163	20.746	24.624	28.799	33.270	38.039

Pb-AI 1 MeV Dose Buildup Factors

Dose	1	2	3	4	5	6	7	8	9	10
1	2.383	3.433	4.554	5.756	7.037	8.395	9.826	11.326	12.891	14.518
2	2.932	4.110	5.351	6.667	8.057	9.520	11.052	12.650	14.310	16.029
3	3.449	4.762	6.128	7.563	9.067	10.639	12.276	13.976	15.734	17.549
4	3.952	5.402	6.897	8.453	10.074	11.758	13.504	15.309	17.169	19.081
5	4.448	6.039	7.664	9.345	11.085	12.884	14.741	16.653	18.616	20.629
6	4.944	6.676	8.435	10.242	12.103	14.020	15.990	18.011	20.080	22.194
7	5.441	7.318	9.210	11.146	13.131	15.167	17.252	19.385	21.561	23.779
8	5.942	7.964	9.993	12.060	14.170	16.327	18.530	20.775	23.060	25.384
9	6.447	8.617	10.785	12.983	15.221	17.501	19.822	22.182	24.579	27.010
10	6.958	9.277	11.586	13.918	16.286	18.691	21.132	23.609	26.118	28.658

Pb-AI 2 MeV Dose Buildup Factors

Dose	1	2	3	4	5	6	7	8	9	10
1	2.196	2.979	3.773	4.582	5.408	6.248	7.100	7.962	8.832	9.708
2	2.733	3.575	4.410	5.254	6.107	6.970	7.842	8.721	9.606	10.494
3	3.262	4.170	5.053	5.933	6.816	7.704	8.596	9.492	10.390	11.290
4	3.792	4.770	5.704	6.622	7.536	8.448	9.360	10.273	11.185	12.097
5	4.327	5.379	6.365	7.323	8.267	9.204	10.136	11.066	11.992	12.914
6	4.869	5.997	7.036	8.034	9.009	9.971	10.924	11.869	12.808	13.741
7	5.420	6.624	7.718	8.756	9.763	10.749	11.721	12.682	13.634	14.577
8	5.979	7.262	8.411	9.490	10.528	11.539	12.530	13.507	14.470	15.423
9	6.547	7.910	9.114	10.234	11.304	12.339	13.349	14.340	15.315	16.275
10	7.124	8.567	9.828	10.989	12.090	13.149	14.178	15.183	16.169	17.138

Pb-AI 6 MeV Dose Buildup Factors

Dose	1	2	3	4	5	6	7	8	9	10
1	1.705	2.152	2.591	3.024	3.453	3.877	4.296	4.710	5.118	5.520
2	1.995	2.420	2.844	3.267	3.687	4.105	4.518	4.926	5.329	5.725
3	2.303	2.707	3.114	3.524	3.935	4.344	4.750	5.151	5.547	5.937
4	2.637	3.016	3.404	3.799	4.198	4.596	4.993	5.385	5.773	6.156
5	3.000	3.352	3.716	4.093	4.476	4.862	5.247	5.630	6.009	6.383
6	3.397	3.716	4.052	4.406	4.772	5.142	5.514	5.885	6.254	6.618
7	3.830	4.111	4.415	4.742	5.086	5.438	5.795	6.152	6.509	6.862
8	4.305	4.541	4.805	5.101	5.420	5.751	6.090	6.432	6.774	7.115
9	4.825	5.009	5.227	5.487	5.775	6.082	6.401	6.725	7.052	7.379
10	5.394	5.517	5.683	5.900	6.155	6.434	6.729	7.033	7.343	7.654

Pb-AI 10 MeV Dose Buildup Factors

Dose	1	2	3	4	5	6	7	8	9	10
1	1.571	1.888	2.207	2.525	2.841	3.155	3.467	3.776	4.082	4.384
2	1.828	2.095	2.386	2.688	2.993	3.298	3.603	3.906	4.207	4.505
3	2.116	2.329	2.588	2.869	3.160	3.455	3.751	4.047	4.342	4.634
4	2.449	2.597	2.817	3.072	3.345	3.626	3.912	4.200	4.487	4.772
5	2.835	2.908	3.078	3.301	3.551	3.816	4.089	4.365	4.643	4.921
6	3.287	3.267	3.377	3.560	3.782	4.026	4.283	4.546	4.813	5.081
7	3.819	3.686	3.722	3.855	4.042	4.261	4.497	4.745	4.998	5.255
8	4.446	4.176	4.120	4.191	4.335	4.522	4.735	4.963	5.200	5.443
9	5.189	4.751	4.582	4.577	4.668	4.816	4.999	5.203	5.421	5.649
10	6.070	5.427	5.119	5.020	5.046	5.147	5.294	5.470	5.665	5.874

Polyethylene Followed by Lead

Poly-Pb 65 keV Dose Buildup Factors

Dose	1	2	3	4	5	6	7	8	9	10
1	1.573	1.530	1.564	1.621	1.689	1.763	1.840	1.920	2.003	2.087
2	2.122	1.895	1.859	1.879	1.925	1.977	2.044	2.117	2.195	2.275
3	2.771	2.310	2.188	2.164	2.183	2.215	2.270	2.335	2.406	2.482
4	3.537	2.783	2.557	2.480	2.467	2.477	2.518	2.572	2.636	2.707
5	4.441	3.322	2.971	2.831	2.780	2.765	2.789	2.832	2.887	2.951
6	5.501	3.934	3.434	3.220	3.125	3.080	3.085	3.114	3.160	3.218
7	6.742	4.629	3.952	3.651	3.506	3.426	3.409	3.423	3.457	3.507
8	8.189	5.418	4.531	4.128	3.907	3.805	3.763	3.759	3.780	3.821
9	9.872	6.311	5.177	4.657	4.385	4.221	4.149	4.125	4.132	4.162
10	11.822	7.321	5.899	5.242	4.891	4.676	4.571	4.523	4.514	4.533

Poly-Pb 100 keV Dose Buildup Factors

Dose	1	2	3	4	5	6	7	8	9	10
1	3.039	3.788	4.897	6.560	9.102	13.089	19.482	29.932	47.304	76.618
2	4.777	5.722	7.361	9.975	14.199	20.963	32.083	50.656	82.123	136.119
3	7.036	8.227	10.598	14.543	21.076	31.745	49.557	79.703	131.368	220.920
4	9.903	11.369	14.674	20.339	29.869	45.627	72.193	117.522	195.761	332.216
5	13.485	15.235	19.691	27.499	40.775	62.911	100.469	164.898	276.620	472.256
6	17.903	19.929	25.769	36.185	54.035	83.969	134.982	222.817	375.604	643.888
7	23.292	25.565	33.044	46.582	69.919	109.223	176.412	292.398	494.606	850.351
8	29.804	32.272	41.667	58.895	88.735	139.147	225.520	374.902	635.740	1095.280
9	37.605	40.191	51.804	73.351	110.815	174.257	283.134	471.692	801.311	1382.590
10	46.883	49.477	63.637	90.195	136.521	215.113	350.154	584.247	993.799	1716.530

Poly-Pb 500 keV Dose Buildup Factors

Dose	1	2	3	4	5	6	7	8	9	10
1	1.650	1.803	1.975	2.153	2.336	2.523	2.713	2.908	3.107	3.309
2	2.050	2.107	2.230	2.376	2.536	2.705	2.882	3.065	3.253	3.446
3	2.464	2.420	2.490	2.604	2.740	2.891	3.053	3.223	3.401	3.584
4	2.897	2.743	2.757	2.836	2.947	3.080	3.227	3.384	3.550	3.724
5	3.350	3.076	3.032	3.073	3.159	3.272	3.402	3.546	3.701	3.865
6	3.824	3.420	3.313	3.315	3.374	3.466	3.580	3.711	3.854	4.008
7	4.320	3.776	3.601	3.563	3.592	3.663	3.760	3.877	4.009	4.152
8	4.837	4.143	3.897	3.815	3.815	3.863	3.943	4.046	4.165	4.298
9	5.377	4.522	4.201	4.070	4.045	4.069	4.129	4.215	4.320	4.447
10	5.936	4.908	4.516	4.339	4.273	4.273	4.314	4.392	4.484	4.593

Poly-Pb 1 MeV Dose Buildup Factors

Dose	1	2	3	4	5	6	7	8	9	10
1	1.854	2.164	2.476	2.786	3.098	3.411	3.727	4.047	4.370	4.697
2	2.343	2.579	2.851	3.137	3.431	3.731	4.037	4.348	4.664	4.985
3	2.843	3.002	3.233	3.492	3.767	4.054	4.349	4.651	4.959	5.274
4	3.359	3.434	3.621	3.853	4.108	4.379	4.662	4.955	5.255	5.562
5	3.890	3.876	4.016	4.218	4.452	4.708	4.978	5.260	5.551	5.851
6	4.437	4.327	4.418	4.588	4.800	5.038	5.295	5.566	5.847	6.140
7	5.000	4.789	4.824	4.961	5.150	5.371	5.615	5.875	6.143	6.427
8	5.577	5.258	5.237	5.339	5.503	5.706	5.935	6.182	6.440	6.715
9	6.169	5.736	5.657	5.722	5.860	6.043	6.256	6.491	6.738	7.003
10	6.773	6.221	6.081	6.107	6.218	6.380	6.577	6.799	7.034	7.290

Poly-Pb 2 MeV Dose Buildup Factors

Dose	1	2	3	4	5	6	7	8	9	10
1	1.939	2.337	2.736	3.139	3.547	3.962	4.383	4.811	5.245	5.686
2	2.469	2.838	3.227	3.627	4.035	4.450	4.874	5.304	5.741	6.185
3	3.000	3.342	3.721	4.116	4.523	4.940	5.364	5.797	6.236	6.682
4	3.534	3.849	4.216	4.607	5.012	5.428	5.854	6.289	6.728	7.176
5	4.072	4.356	4.712	5.099	5.500	5.917	6.341	6.776	7.219	7.665
6	4.612	4.866	5.209	5.589	5.987	6.403	6.826	7.262	7.705	8.152
7	5.155	5.376	5.706	6.079	6.473	6.886	7.308	7.744	8.187	8.634
8	5.698	5.886	6.201	6.566	6.955	7.366	7.787	8.221	8.665	9.111
9	6.241	6.394	6.694	7.050	7.435	7.843	8.261	8.695	9.137	9.582
10	6.784	6.901	7.184	7.532	7.910	8.315	8.731	9.162	9.604	10.048

Poly-Pb 6 MeV Dose Buildup Factors

Dose	1	2	3	4	5	6	7	8	9	10
1	1.877	2.227	2.604	3.013	3.462	3.953	4.492	5.084	5.735	6.450
2	2.380	2.786	3.227	3.708	4.236	4.815	5.450	6.147	6.913	7.754
3	2.854	3.319	3.824	4.378	4.985	5.650	6.380	7.178	8.058	9.023
4	3.308	3.830	4.399	5.024	5.708	6.458	7.280	8.179	9.168	10.254
5	3.743	4.323	4.954	5.648	6.407	7.238	8.150	9.147	10.243	11.446
6	4.162	4.797	5.490	6.250	7.081	7.993	8.991	10.082	11.283	12.599
7	4.566	5.255	6.006	6.830	7.733	8.721	9.799	10.986	12.287	13.713
8	4.954	5.694	6.501	7.387	8.356	9.418	10.576	11.850	13.247	14.778
9	5.328	6.119	6.981	7.927	8.962	10.095	11.331	12.691	14.182	15.815
10	5.689	6.528	7.443	8.446	9.545	10.747	12.064	13.501	15.082	16.814

Poly-Pb 10 MeV Dose Buildup Factors

Dose	1	2	3	4	5	6	7	8	9	10
1	1.905	2.321	2.786	3.322	3.948	4.686	5.561	6.600	7.840	9.322
2	2.351	2.856	3.429	4.093	4.875	5.799	6.902	8.214	9.783	11.664
3	2.759	3.351	4.027	4.814	5.742	6.845	8.162	9.733	11.615	13.876
4	3.142	3.816	4.590	5.493	6.562	7.832	9.353	11.170	13.350	15.971
5	3.502	4.256	5.123	6.137	7.339	8.769	10.484	12.535	14.998	17.961
6	3.845	4.674	5.629	6.749	8.077	9.660	11.559	13.832	16.564	19.853
7	4.170	5.072	6.111	7.331	8.780	10.507	12.582	15.067	18.056	21.656
8	4.480	5.450	6.570	7.886	9.449	11.315	13.557	16.243	19.476	23.372
9	4.776	5.811	7.008	8.415	10.087	12.085	14.486	17.365	20.831	25.009
10	5.057	6.155	7.425	8.919	10.695	12.819	15.372	18.434	22.122	26.570

Lead Followed by Polyethylene (Pb-Poly)

Pb-Poly 65 keV Dose Buildup Factors

Dose	1	2	3	4	5	6	7	8	9	10
1	2.890	5.825	10.368	16.929	26.017	38.236	54.280	74.946	101.147	133.924
2	3.112	6.251	11.101	18.094	27.770	40.763	57.805	79.734	107.513	142.233
3	3.327	6.665	11.816	19.235	29.489	43.246	61.274	84.454	113.794	150.441
4	3.538	7.074	12.524	20.367	31.196	45.714	64.725	89.152	120.050	158.620
5	3.748	7.482	13.231	21.496	32.902	48.180	68.175	93.850	126.310	166.808
6	3.958	7.889	13.937	22.626	34.608	50.649	71.631	98.558	132.583	175.013
7	4.168	8.297	14.646	23.761	36.323	53.131	75.104	103.291	138.891	183.266
8	4.379	8.707	15.358	24.900	38.044	55.622	78.592	108.045	145.228	191.560
9	4.590	9.120	16.074	26.046	39.777	58.131	82.105	112.834	151.614	199.918
10	4.803	9.534	16.794	27.200	41.521	60.658	85.644	117.658	158.047	208.339

Pb-Poly 100 keV Dose Buildup Factors

Dose	1	2	3	4	5	6	7	8	9	10
1	3.231	6.389	11.393	18.762	29.143	43.301	62.120	86.613	117.932	157.381
2	4.277	8.136	14.143	22.815	34.816	50.932	72.066	99.254	133.672	176.649
3	5.708	10.576	18.014	28.550	42.872	61.794	86.247	117.296	156.145	204.153
4	7.781	14.161	23.743	37.075	54.888	78.038	107.498	144.374	189.911	245.510
5	10.900	19.618	32.516	50.189	73.436	103.188	140.486	186.500	242.539	310.065
6	15.729	28.149	46.310	70.895	102.830	143.172	193.078	253.830	326.845	413.692
7	23.384	41.783	68.467	104.292	150.410	208.102	278.734	363.790	464.875	583.747
8	35.758	63.976	104.706	159.128	228.803	315.421	420.729	546.574	694.912	867.840
9	56.097	100.679	164.898	250.543	359.920	495.465	659.626	854.927	1083.970	1349.460
10	90.032	162.244	266.263	405.009	582.159	801.518	1066.830	1381.850	1750.420	2176.410

Pb-Poly 500 keV Dose Buildup Factors

Dose	1	2	3	4	5	6	7	8	9	10
1	2.457	3.926	5.785	8.062	10.779	13.953	17.596	21.719	26.330	31.435
2	2.864	4.518	6.603	9.146	12.167	15.678	19.692	24.215	29.255	34.816
3	3.242	5.077	7.384	10.189	13.509	17.356	21.739	26.663	32.135	38.159
4	3.608	5.623	8.152	11.218	14.837	19.021	23.774	29.103	35.009	41.499
5	3.969	6.166	8.917	12.245	16.167	20.689	25.818	31.555	37.905	44.865
6	4.330	6.710	9.685	13.279	17.505	22.371	27.880	34.032	40.829	48.268
7	4.693	7.258	10.461	14.323	18.858	24.072	29.966	36.539	43.791	51.717
8	5.060	7.813	11.246	15.380	20.229	25.796	32.082	39.084	46.798	55.224
9	5.432	8.376	12.042	16.453	21.621	27.548	34.233	41.671	49.855	58.786
10	5.809	8.947	12.851	17.544	23.036	29.329	36.419	44.301	52.968	62.410

Pb-Poly 1 MeV Dose Buildup Factors

Dose	1	2	3	4	5	6	7	8	9	10
1	2.424	3.611	4.938	6.394	7.971	9.660	11.455	13.347	15.333	17.404
2	2.987	4.338	5.830	7.447	9.178	11.015	12.952	14.982	17.100	19.299
3	3.516	5.036	6.696	8.477	10.367	12.358	14.442	16.613	18.868	21.199
4	4.029	5.721	7.552	9.500	11.552	13.699	15.934	18.251	20.647	23.113
5	4.537	6.402	8.405	10.523	12.739	15.046	17.435	19.902	22.441	25.046
6	5.044	7.083	9.261	11.550	13.934	16.403	18.950	21.568	24.253	26.999
7	5.552	7.767	10.123	12.586	15.140	17.773	20.480	23.252	26.087	28.976
8	6.064	8.458	10.992	13.632	16.358	19.159	22.028	24.956	27.943	30.978
9	6.580	9.155	11.871	14.690	17.590	20.561	23.593	26.680	29.820	33.003
10	7.102	9.860	12.760	15.760	18.838	21.981	25.179	28.428	31.723	35.057

Pb-Poly 2 MeV Dose Buildup Factors

Dose	1	2	3	4	5	6	7	8	9	10
1	2.217	3.055	3.903	4.765	5.640	6.528	7.425	8.329	9.237	10.148
2	2.763	3.672	4.571	5.470	6.374	7.285	8.201	9.120	10.041	10.962
3	3.299	4.288	5.243	6.183	7.118	8.053	8.988	9.923	10.856	11.787
4	3.836	4.910	5.923	6.906	7.874	8.833	9.788	10.738	11.683	12.623
5	4.378	5.540	6.614	7.640	8.640	9.625	10.598	11.563	12.520	13.468
6	4.928	6.179	7.315	8.386	9.419	10.428	11.421	12.400	13.367	14.324
7	5.486	6.828	8.028	9.144	10.209	11.243	12.254	13.247	14.225	15.189
8	6.054	7.489	8.752	9.914	11.012	12.070	13.099	14.106	15.093	16.064
9	6.630	8.159	9.487	10.694	11.826	12.908	13.955	14.974	15.970	16.947
10	7.215	8.840	10.233	11.486	12.650	13.756	14.820	15.851	16.856	17.838

Pb-Poly 6 MeV Dose Buildup Factors

Dose	1	2	3	4	5	6	7	8	9	10
1	1.688	2.138	2.568	2.980	3.377	3.759	4.127	4.482	4.824	5.153
2	1.957	2.373	2.781	3.177	3.561	3.933	4.292	4.638	4.972	5.294
3	2.243	2.624	3.006	3.384	3.754	4.114	4.462	4.799	5.125	5.438
4	2.552	2.893	3.247	3.603	3.956	4.302	4.638	4.965	5.281	5.586
5	2.887	3.184	3.503	3.834	4.168	4.498	4.821	5.135	5.441	5.736
6	3.253	3.497	3.777	4.079	4.390	4.702	5.010	5.312	5.605	5.891
7	3.652	3.836	4.070	4.339	4.624	4.916	5.206	5.493	5.775	6.049
8	4.088	4.202	4.383	4.614	4.870	5.138	5.410	5.681	5.949	6.210
9	4.565	4.599	4.720	4.906	5.130	5.372	5.623	5.876	6.128	6.377
10	5.086	5.029	5.081	5.217	5.403	5.616	5.844	6.078	6.314	6.548

Pb-Poly 10 MeV Dose Buildup Factors

Dose	1	2	3	4	5	6	7	8	9	10
1	1.516	1.839	2.150	2.446	2.728	2.995	3.250	3.494	3.725	3.947
2	1.723	1.986	2.269	2.549	2.819	3.077	3.325	3.562	3.789	4.005
3	1.955	2.151	2.400	2.660	2.916	3.165	3.404	3.634	3.855	4.065
4	2.221	2.336	2.545	2.781	3.021	3.258	3.488	3.710	3.923	4.128
5	2.528	2.547	2.707	2.913	3.134	3.357	3.576	3.789	3.995	4.194
6	2.886	2.788	2.887	3.059	3.257	3.463	3.670	3.873	4.071	4.262
7	3.305	3.065	3.090	3.220	3.391	3.578	3.771	3.962	4.150	4.334
8	3.797	3.384	3.320	3.398	3.537	3.702	3.878	4.057	4.234	4.409
9	4.375	3.752	3.580	3.597	3.698	3.837	3.993	4.157	4.323	4.488
10	5.060	4.181	3.876	3.820	3.876	3.984	4.118	4.265	4.418	4.572

Stainless Steel Followed by Lead

SS- Pb 65 keV Dose Buildup Factors

Dose	1	2	3	4	5	6	7	8	9	10
1	1.247	1.329	1.413	1.498	1.583	1.669	1.755	1.841	1.928	2.016
2	1.364	1.439	1.519	1.602	1.686	1.771	1.857	1.944	2.031	2.119
3	1.476	1.547	1.625	1.707	1.790	1.875	1.961	2.048	2.136	2.225
4	1.587	1.655	1.731	1.812	1.895	1.980	2.066	2.154	2.242	2.332
5	1.698	1.763	1.838	1.919	2.002	2.087	2.173	2.261	2.350	2.440
6	1.810	1.872	1.947	2.027	2.110	2.195	2.282	2.370	2.460	2.551
7	1.922	1.983	2.056	2.136	2.219	2.304	2.392	2.481	2.571	2.664
8	2.036	2.095	2.168	2.247	2.330	2.416	2.504	2.594	2.686	2.779
9	2.151	2.208	2.280	2.360	2.443	2.529	2.618	2.709	2.801	2.896
10	2.268	2.323	2.395	2.474	2.558	2.645	2.734	2.826	2.919	3.015

SS- Pb 100 keV Dose Buildup Factors

Dose	1	2	3	4	5	6	7	8	9	10
1	2.205	2.924	3.854	5.161	7.086	10.026	14.640	22.048	34.172	54.344
2	2.600	3.409	4.474	5.991	8.249	11.730	17.234	26.134	40.789	65.311
3	2.981	3.886	5.086	6.813	9.401	13.413	19.795	30.162	47.311	76.123
4	3.366	4.369	5.709	7.647	10.569	15.119	22.386	34.234	53.895	87.027
5	3.759	4.866	6.349	8.505	11.768	16.868	25.038	38.394	60.612	98.135
6	4.165	5.380	7.012	9.392	13.007	18.673	27.771	42.676	67.518	109.542
7	4.586	5.913	7.700	10.313	14.292	20.542	30.599	47.102	74.649	121.312
8	5.025	6.469	8.416	11.271	15.627	22.484	33.535	51.694	82.043	133.508
9	5.482	7.048	9.162	12.269	17.019	24.507	36.592	56.474	89.735	146.192
10	5.958	7.652	9.941	13.311	18.471	26.617	39.779	61.456	97.751	159.405

SS- Pb 500 keV Dose Buildup Factors

Dose	1	2	3	4	5	6	7	8	9	10
1	1.667	1.825	2.001	2.182	2.368	2.558	2.752	2.949	3.150	3.355
2	2.087	2.156	2.286	2.439	2.605	2.780	2.962	3.150	3.343	3.542
3	2.527	2.501	2.582	2.705	2.850	3.009	3.179	3.357	3.541	3.732
4	2.990	2.861	2.891	2.981	3.103	3.245	3.402	3.569	3.744	3.928
5	3.480	3.239	3.212	3.267	3.364	3.489	3.631	3.786	3.953	4.127
6	3.996	3.633	3.545	3.563	3.635	3.739	3.866	4.009	4.165	4.331
7	4.541	4.046	3.892	3.869	3.913	3.997	4.109	4.239	4.384	4.541
8	5.116	4.477	4.253	4.187	4.201	4.263	4.357	4.474	4.608	4.755
9	5.721	4.928	4.628	4.516	4.499	4.538	4.613	4.716	4.838	4.975
10	6.357	5.398	5.018	4.857	4.806	4.820	4.877	4.964	5.073	5.199

SS- Pb 1 MeV Dose Buildup Factors

Dose	1	2	3	4	5	6	7	8	9	10
1	1.861	2.173	2.487	2.799	3.112	3.427	3.744	4.066	4.390	4.719
2	2.359	2.599	2.875	3.164	3.462	3.765	4.074	4.388	4.707	5.030
3	2.870	3.037	3.273	3.538	3.818	4.108	4.408	4.714	5.027	5.345
4	3.400	3.486	3.681	3.919	4.181	4.458	4.746	5.044	5.350	5.662
5	3.948	3.949	4.099	4.308	4.550	4.812	5.090	5.378	5.676	5.982
6	4.516	4.424	4.526	4.705	4.925	5.172	5.437	5.715	6.005	6.304
7	5.103	4.911	4.962	5.109	5.307	5.536	5.788	6.056	6.336	6.628
8	5.708	5.412	5.408	5.520	5.694	5.905	6.143	6.400	6.671	6.954
9	6.332	5.924	5.863	5.939	6.087	6.279	6.502	6.746	7.007	7.282
10	6.973	6.448	6.326	6.364	6.485	6.657	6.863	7.095	7.346	7.612

SS- Pb 2 MeV Dose Buildup Factors

Dose	1	2	3	4	5	6	7	8	9	10
1	1.932	2.329	2.729	3.133	3.542	3.957	4.378	4.806	5.241	5.683
2	2.462	2.831	3.220	3.620	4.029	4.445	4.869	5.300	5.738	6.183
3	3.000	3.341	3.720	4.115	4.523	4.940	5.365	5.799	6.239	6.686
4	3.548	3.860	4.227	4.617	5.023	5.440	5.866	6.301	6.743	7.191
5	4.107	4.388	4.741	5.126	5.528	5.944	6.370	6.806	7.249	7.699
6	4.677	4.924	5.263	5.639	6.038	6.452	6.878	7.313	7.756	8.207
7	5.255	5.467	5.789	6.158	6.552	6.963	7.387	7.822	8.265	8.715
8	5.843	6.016	6.321	6.680	7.069	7.476	7.898	8.332	8.774	9.224
9	6.437	6.571	6.857	7.205	7.587	7.991	8.410	8.841	9.282	9.731
10	7.038	7.130	7.396	7.732	8.107	8.506	8.922	9.351	9.790	10.238

SS- Pb 6 MeV Dose Buildup Factors

Dose	1	2	3	4	5	6	7	8	9	10
1	1.775	2.110	2.470	2.861	3.289	3.759	4.274	4.840	5.463	6.147
2	2.226	2.601	3.011	3.460	3.952	4.492	5.085	5.737	6.453	7.239
3	2.686	3.107	3.572	4.082	4.641	5.256	5.931	6.671	7.485	8.379
4	3.157	3.629	4.151	4.725	5.356	6.048	6.808	7.642	8.558	9.564
5	3.642	4.167	4.749	5.390	6.094	6.867	7.716	8.647	9.668	10.790
6	4.141	4.720	5.365	6.075	6.855	7.711	8.651	9.682	10.813	12.053
7	4.653	5.288	5.997	6.778	7.637	8.579	9.613	10.746	11.989	13.352
8	5.177	5.869	6.644	7.499	8.438	9.468	10.598	11.836	13.194	14.683
9	5.713	6.464	7.306	8.235	9.256	10.376	11.604	12.951	14.426	16.043
10	6.259	7.070	7.981	8.987	10.091	11.303	12.631	14.087	15.683	17.431

SS- Pb 10 MeV Dose Buildup Factors

Dose	1	2	3	4	5	6	7	8	9	10
1	1.791	2.178	2.610	3.107	3.687	4.370	5.178	6.137	7.280	8.645
2	2.189	2.644	3.163	3.767	4.475	5.313	6.309	7.495	8.912	10.610
3	2.597	3.131	3.745	4.463	5.312	6.318	7.518	8.950	10.666	12.725
4	3.022	3.640	4.357	5.200	6.199	7.387	8.806	10.505	12.543	14.992
5	3.468	4.176	5.003	5.979	7.139	8.522	10.177	12.161	14.546	17.415
6	3.935	4.740	5.684	6.802	8.133	9.724	11.632	13.922	16.677	19.996
7	4.425	5.332	6.401	7.670	9.184	10.997	13.173	15.789	18.939	22.739
8	4.940	5.955	7.155	8.584	10.292	12.340	14.801	17.764	21.335	25.645
9	5.478	6.608	7.948	9.545	11.459	13.755	16.519	19.848	23.865	28.716
10	6.042	7.292	8.778	10.554	12.683	15.243	18.325	22.043	26.530	31.954

Lead Followed by Stainless Steel (Pb-SS)

Pb-SS 65 keV Dose Buildup Factors

Dose	1	2	3	4	5	6	7	8	9	10
1	1.286	1.418	1.541	1.661	1.780	1.899	2.018	2.139	2.261	2.385
2	1.382	1.514	1.637	1.758	1.879	1.999	2.120	2.243	2.367	2.492
3	1.475	1.608	1.733	1.856	1.978	2.100	2.223	2.347	2.473	2.600
4	1.567	1.702	1.829	1.954	2.077	2.201	2.326	2.452	2.579	2.708
5	1.658	1.796	1.926	2.052	2.177	2.303	2.430	2.557	2.687	2.818
6	1.750	1.891	2.022	2.150	2.278	2.405	2.534	2.664	2.795	2.928
7	1.842	1.985	2.119	2.250	2.379	2.509	2.639	2.771	2.905	3.040
8	1.934	2.080	2.217	2.349	2.481	2.613	2.745	2.879	3.015	3.153
9	2.026	2.176	2.315	2.450	2.584	2.718	2.852	2.989	3.127	3.267
10	2.119	2.272	2.414	2.551	2.687	2.824	2.961	3.099	3.240	3.382

Pb-SS 100 keV Dose Buildup Factors

Dose	1	2	3	4	5	6	7	8	9	10
1	1.476	1.711	1.970	2.236	2.510	2.793	3.086	3.391	3.708	4.039
2	1.671	1.814	2.042	2.296	2.566	2.848	3.141	3.447	3.766	4.100
3	1.948	1.954	2.133	2.367	2.627	2.905	3.197	3.503	3.824	4.159
4	2.366	2.162	2.260	2.458	2.701	2.969	3.257	3.562	3.882	4.219
5	3.017	2.489	2.453	2.588	2.798	3.049	3.327	3.626	3.944	4.279
6	4.066	3.026	2.765	2.789	2.940	3.156	3.414	3.702	4.013	4.345
7	5.795	3.931	3.293	3.124	3.167	3.319	3.538	3.801	4.097	4.420
8	8.694	5.492	4.213	3.704	3.551	3.586	3.731	3.947	4.213	4.516
9	13.631	8.225	5.846	4.735	4.229	4.047	4.054	4.180	4.387	4.652
10	22.141	13.061	8.779	6.598	5.453	4.871	4.621	4.578	4.674	4.865

Pb-SS 500 keV Dose Buildup Factors

Dose	1	2	3	4	5	6	7	8	9	10
1	2.238	3.200	4.228	5.341	6.547	7.851	9.255	10.763	12.375	14.093
2	2.602	3.658	4.779	5.989	7.296	8.703	10.214	11.831	13.556	15.392
3	2.942	4.094	5.314	6.624	8.033	9.546	11.166	12.897	14.738	16.694
4	3.271	4.523	5.843	7.255	8.769	10.391	12.122	13.968	15.929	18.007
5	3.597	4.951	6.372	7.888	9.509	11.242	13.088	15.051	17.134	19.338
6	3.922	5.381	6.905	8.527	10.258	12.103	14.065	16.149	18.357	20.688
7	4.250	5.813	7.444	9.173	11.015	12.975	15.057	17.263	19.596	22.060
8	4.581	6.252	7.990	9.829	11.784	13.861	16.064	18.396	20.859	23.455
9	4.916	6.697	8.544	10.495	12.566	14.761	17.088	19.547	22.142	24.874
10	5.257	7.148	9.106	11.172	13.360	15.677	18.130	20.719	23.448	26.319

Pb-SS 1 MeV Dose Buildup Factors

Dose	1	2	3	4	5	6	7	8	9	10
1	2.306	3.236	4.212	5.245	6.336	7.484	8.689	9.946	11.255	12.613
2	2.831	3.859	4.926	6.045	7.219	8.447	9.728	11.061	12.442	13.871
3	3.326	4.461	5.625	6.835	8.096	9.407	10.769	12.179	13.636	15.139
4	3.807	5.053	6.317	7.621	8.972	10.369	11.814	13.305	14.840	16.418
5	4.283	5.642	7.009	8.410	9.852	11.338	12.868	14.441	16.056	17.712
6	4.758	6.232	7.703	9.203	10.739	12.315	13.932	15.590	17.285	19.020
7	5.235	6.825	8.403	10.003	11.636	13.304	15.009	16.751	18.531	20.345
8	5.715	7.423	9.110	10.812	12.542	14.303	16.099	17.929	19.792	21.688
9	6.199	8.028	9.824	11.630	13.458	15.315	17.202	19.120	21.069	23.048
10	6.689	8.639	10.547	12.458	14.387	16.340	18.320	20.328	22.363	24.427

Pb-SS 2 MeV Dose Buildup Factors

Dose	1	2	3	4	5	6	7	8	9	10
1	2.162	2.906	3.662	4.438	5.234	6.050	6.884	7.733	8.596	9.470
2	2.689	3.483	4.280	5.090	5.916	6.758	7.614	8.484	9.365	10.257
3	3.207	4.061	4.902	5.750	6.607	7.476	8.356	9.247	10.147	11.055
4	3.726	4.644	5.534	6.419	7.309	8.205	9.109	10.021	10.939	11.863
5	4.251	5.235	6.175	7.100	8.022	8.947	9.875	10.807	11.743	12.683
6	4.782	5.835	6.825	7.791	8.747	9.699	10.651	11.603	12.557	13.512
7	5.322	6.445	7.487	8.493	9.482	10.462	11.437	12.410	13.381	14.351
8	5.870	7.064	8.159	9.207	10.229	11.237	12.236	13.228	14.216	15.200
9	6.427	7.693	8.841	9.930	10.986	12.021	13.043	14.055	15.059	16.057
10	6.993	8.332	9.533	10.664	11.754	12.816	13.861	14.892	15.912	16.924

Pb-SS 6 MeV Dose Buildup Factors

Dose	1	2	3	4	5	6	7	8	9	10
1	1.731	2.179	2.633	3.101	3.582	4.077	4.586	5.107	5.640	6.183
2	2.047	2.493	2.949	3.419	3.904	4.404	4.918	5.443	5.981	6.528
3	2.384	2.831	3.289	3.761	4.250	4.753	5.271	5.800	6.340	6.891
4	2.749	3.199	3.657	4.131	4.621	5.127	5.647	6.178	6.721	7.274
5	3.148	3.600	4.057	4.530	5.021	5.527	6.048	6.580	7.124	7.678
6	3.584	4.037	4.491	4.962	5.451	5.956	6.476	7.008	7.551	8.105
7	4.062	4.514	4.964	5.430	5.914	6.416	6.933	7.463	8.005	8.556
8	4.586	5.036	5.478	5.936	6.413	6.909	7.421	7.947	8.485	9.034
9	5.161	5.606	6.037	6.484	6.952	7.439	7.944	8.464	8.996	9.540
10	5.793	6.230	6.646	7.078	7.533	8.009	8.504	9.015	9.540	10.076

Pb-SS 10 MeV Dose Buildup Factors

Dose	1	2	3	4	5	6	7	8	9	10
1	1.664	2.008	2.366	2.742	3.137	3.553	3.991	4.450	4.931	5.435
2	1.981	2.306	2.654	3.027	3.424	3.843	4.286	4.752	5.241	5.753
3	2.338	2.646	2.985	3.354	3.750	4.173	4.620	5.092	5.588	6.108
4	2.749	3.041	3.369	3.731	4.125	4.549	5.000	5.476	5.979	6.506
5	3.228	3.503	3.815	4.168	4.558	4.980	5.432	5.913	6.420	6.954
6	3.791	4.044	4.337	4.676	5.058	5.476	5.927	6.410	6.921	7.459
7	4.455	4.681	4.949	5.270	5.638	6.049	6.496	6.978	7.491	8.033
8	5.242	5.434	5.669	5.964	6.314	6.712	7.152	7.630	8.141	8.684
9	6.176	6.326	6.519	6.780	7.104	7.483	7.911	8.380	8.887	9.428
10	7.289	7.386	7.524	7.740	8.029	8.383	8.790	9.246	9.744	10.280

Aluminum followed by Stainless Steel (Al-SS)

Al-SS 65 keV Dose Buildup

Dose	1	2	3	4	5	6	7	8	9	10
1	1.559	1.626	1.722	1.829	1.940	2.055	2.173	2.293	2.415	2.540
2	1.957	1.962	2.031	2.124	2.228	2.339	2.456	2.576	2.700	2.826
3	2.389	2.332	2.373	2.450	2.546	2.652	2.767	2.887	3.012	3.141
4	2.861	2.739	2.749	2.809	2.895	2.997	3.109	3.229	3.354	3.486
5	3.382	3.188	3.163	3.204	3.279	3.374	3.484	3.603	3.730	3.863
6	3.955	3.683	3.620	3.639	3.702	3.790	3.894	4.013	4.142	4.276
7	4.590	4.228	4.123	4.116	4.165	4.243	4.346	4.464	4.590	4.730
8	5.288	4.829	4.676	4.641	4.674	4.742	4.840	4.956	5.083	5.225
9	6.057	5.491	5.284	5.218	5.233	5.290	5.382	5.496	5.623	5.768
10	6.906	6.219	5.952	5.852	5.846	5.890	5.975	6.087	6.214	6.361

Al-SS 100 keV Dose Buildup

Dose	1	2	3	4	5	6	7	8	9	10
1	1.886	2.092	2.332	2.588	2.858	3.141	3.437	3.747	4.072	4.412
2	2.482	2.595	2.796	3.035	3.297	3.579	3.878	4.195	4.529	4.881
3	3.135	3.148	3.305	3.523	3.775	4.055	4.357	4.680	5.023	5.386
4	3.857	3.756	3.864	4.056	4.297	4.572	4.876	5.205	5.556	5.930
5	4.657	4.426	4.475	4.638	4.864	5.134	5.437	5.770	6.130	6.513
6	5.546	5.165	5.146	5.274	5.481	5.743	6.044	6.379	6.746	7.139
7	6.531	5.978	5.881	5.967	6.151	6.401	6.699	7.036	7.409	7.812
8	7.623	6.872	6.685	6.722	6.878	7.114	7.406	7.745	8.121	8.533
9	8.830	7.855	7.563	7.543	7.666	7.885	8.168	8.506	8.886	9.305
10	10.162	8.932	8.521	8.436	8.521	8.717	8.989	9.321	9.707	10.133

Al-SS 500 keV Dose Buildup

Dose	1	2	3	4	5	6	7	8	9	10
1	2.697	3.625	4.636	5.738	6.932	8.222	9.611	11.101	12.692	14.387
2	3.671	4.651	5.733	6.912	8.189	9.563	11.038	12.614	14.293	16.078
3	4.747	5.775	6.927	8.182	9.539	10.997	12.556	14.219	15.986	17.859
4	5.933	7.003	8.220	9.550	10.985	12.525	14.167	15.915	17.769	19.730
5	7.235	8.338	9.615	11.016	12.528	14.147	15.872	17.704	19.644	21.693
6	8.656	9.782	11.114	12.582	14.168	15.865	17.671	19.587	21.612	23.747
7	10.200	11.337	12.718	14.250	15.907	17.680	19.565	21.563	23.672	25.894
8	11.869	13.004	14.429	16.020	17.745	19.592	21.555	23.634	25.826	28.134
9	13.663	14.785	16.246	17.892	19.683	21.602	23.641	25.799	28.074	30.466
10	15.584	16.682	18.172	19.869	21.722	23.711	25.824	28.060	30.417	32.892

Al-SS 1 MeV Dose Buildup

Dose	1	2	3	4	5	6	7	8	9	10
1	2.561	3.456	4.409	5.421	6.493	7.621	8.805	10.041	11.328	12.663
2	3.469	4.410	5.416	6.482	7.606	8.785	10.016	11.299	12.629	14.006
3	4.439	5.424	6.481	7.598	8.770	9.996	11.273	12.599	13.971	15.388
4	5.473	6.498	7.601	8.765	9.984	11.254	12.574	13.940	15.351	16.805
5	6.570	7.629	8.774	9.981	11.243	12.555	13.915	15.319	16.767	18.255
6	7.726	8.815	9.998	11.245	12.546	13.897	15.294	16.735	18.216	19.737
7	8.938	10.051	11.269	12.553	13.891	15.278	16.710	18.184	19.697	21.249
8	10.205	11.337	12.585	13.903	15.275	16.695	18.159	19.665	21.207	22.787
9	11.522	12.668	13.943	15.291	16.695	18.146	19.640	21.175	22.745	24.351
10	12.887	14.043	15.342	16.718	18.150	19.629	21.151	22.713	24.309	25.939

Al-SS 2 MeV Dose Buildup

Dose	1	2	3	4	5	6	7	8	9	10
1	2.319	3.048	3.797	4.567	5.359	6.170	6.998	7.842	8.699	9.568
2	3.049	3.797	4.568	5.359	6.170	6.998	7.841	8.698	9.566	10.445
3	3.795	4.563	5.354	6.165	6.992	7.836	8.692	9.560	10.438	11.325
4	4.558	5.344	6.154	6.982	7.824	8.681	9.549	10.427	11.313	12.206
5	5.335	6.138	6.965	7.807	8.663	9.531	10.409	11.296	12.188	13.086
6	6.126	6.943	7.784	8.640	9.508	10.386	11.272	12.165	13.063	13.965
7	6.927	7.757	8.611	9.478	10.356	11.243	12.136	13.034	13.936	14.840
8	7.737	8.577	9.442	10.320	11.206	12.100	12.999	13.901	14.805	15.712
9	8.554	9.402	10.277	11.163	12.057	12.956	13.859	14.763	15.669	16.576
10	9.376	10.231	11.113	12.007	12.905	13.808	14.714	15.622	16.529	17.436

Al-SS 6 MeV Dose Buildup

Dose	1	2	3	4	5	6	7	8	9	10
1	1.934	2.402	2.873	3.355	3.849	4.356	4.875	5.405	5.947	6.499
2	2.421	2.908	3.399	3.900	4.412	4.936	5.472	6.017	6.573	7.137
3	2.896	3.406	3.919	4.440	4.971	5.512	6.063	6.623	7.192	7.768
4	3.363	3.899	4.433	4.974	5.524	6.082	6.648	7.221	7.802	8.390
5	3.825	4.386	4.942	5.503	6.070	6.644	7.225	7.812	8.404	9.003
6	4.281	4.867	5.445	6.025	6.610	7.198	7.793	8.393	8.996	9.605
7	4.731	5.342	5.941	6.540	7.142	7.744	8.353	8.965	9.579	10.198
8	5.176	5.810	6.431	7.048	7.663	8.282	8.904	9.525	10.151	10.777
9	5.614	6.272	6.912	7.547	8.178	8.810	9.444	10.076	10.712	11.347
10	6.045	6.725	7.385	8.036	8.682	9.328	9.974	10.617	11.262	11.905

Al-SS 10 MeV Dose Buildup

Dose	1	2	3	4	5	6	7	8	9	10
1	1.791	2.178	2.568	2.971	3.392	3.831	4.291	4.772	5.275	5.800
2	2.181	2.595	3.013	3.445	3.896	4.365	4.856	5.367	5.901	6.457
3	2.557	3.002	3.452	3.915	4.395	4.895	5.416	5.959	6.523	7.110
4	2.926	3.405	3.886	4.380	4.891	5.422	5.973	6.546	7.141	7.758
5	3.290	3.803	4.315	4.841	5.383	5.944	6.525	7.127	7.753	8.400
6	3.649	4.196	4.742	5.298	5.870	6.460	7.071	7.705	8.359	9.035
7	4.005	4.586	5.163	5.750	6.352	6.972	7.612	8.275	8.958	9.663
8	4.357	4.971	5.580	6.196	6.828	7.477	8.146	8.838	9.550	10.284
9	4.705	5.352	5.992	6.638	7.298	7.976	8.674	9.394	10.134	10.896
10	5.048	5.728	6.398	7.074	7.763	8.469	9.194	9.943	10.710	11.500

Stainless Steel Followed by Aluminium (SS-Al)

SS-Al 65 keV Dose Buildup

Dose	1	2	3	4	5	6	7	8	9	10
1	1.957	2.652	3.373	4.148	4.995	5.925	6.951	8.083	9.331	10.708
2	2.149	2.886	3.647	4.465	5.358	6.338	7.416	8.604	9.914	11.358
3	2.332	3.113	3.918	4.781	5.720	6.750	7.882	9.129	10.502	12.014
4	2.512	3.339	4.188	5.097	6.084	7.165	8.352	9.657	11.095	12.676
5	2.691	3.565	4.460	5.415	6.451	7.584	8.827	10.193	11.695	13.348
6	2.871	3.793	4.734	5.736	6.822	8.008	9.308	10.735	12.304	14.029
7	3.052	4.022	5.011	6.061	7.198	8.437	9.795	11.285	12.922	14.721
8	3.235	4.255	5.291	6.390	7.579	8.874	10.291	11.844	13.550	15.424
9	3.420	4.490	5.575	6.724	7.965	9.316	10.793	12.411	14.188	16.138
10	3.608	4.729	5.863	7.063	8.358	9.766	11.304	12.989	14.837	16.866

SS-Al 100 keV Dose Buildup

Dose	1	2	3	4	5	6	7	8	9	10
1	2.436	3.627	4.921	6.360	7.970	9.774	11.794	14.050	16.565	19.363
2	2.888	4.203	5.626	7.204	8.965	10.934	13.133	15.585	18.314	21.344
3	3.325	4.775	6.336	8.062	9.982	12.123	14.511	17.168	20.121	23.395
4	3.765	5.356	7.065	8.945	11.033	13.357	15.942	18.815	22.003	25.533
5	4.213	5.954	7.816	9.860	12.123	14.637	17.429	20.529	23.962	27.761
6	4.676	6.574	8.597	10.811	13.258	15.971	18.982	22.318	26.009	30.089
7	5.156	7.218	9.409	11.802	14.442	17.365	20.603	24.187	28.149	32.523
8	5.654	7.889	10.257	12.838	15.680	18.823	22.299	26.145	30.390	35.071
9	6.173	8.589	11.143	13.920	16.975	20.347	24.074	28.191	32.732	37.738
10	6.717	9.321	12.068	15.052	18.328	21.940	25.929	30.331	35.183	40.527

SS-AI 500 keV Dose Buildup

Dose	1	2	3	4	5	6	7	8	9	10
1	2.941	4.192	5.598	7.174	8.931	10.873	13.007	15.335	17.860	20.586
2	4.048	5.508	7.122	8.908	10.876	13.034	15.387	17.937	20.689	23.644
3	5.259	6.955	8.796	10.806	12.999	15.383	17.964	20.746	23.731	26.923
4	6.583	8.539	10.624	12.872	15.302	17.922	20.741	23.762	26.989	30.425
5	8.026	10.262	12.608	15.109	17.786	20.653	23.719	26.989	30.465	34.153
6	9.591	12.128	14.752	17.518	20.455	23.580	26.903	30.430	34.164	38.110
7	11.282	14.140	17.056	20.101	23.311	26.704	30.293	34.085	38.085	42.299
8	13.101	16.300	19.526	22.864	26.358	30.030	33.895	37.962	42.236	46.724
9	15.049	18.610	22.162	25.807	29.598	33.560	37.711	42.062	46.619	51.389
10	17.130	21.073	24.967	28.934	33.033	37.295	41.743	46.387	51.235	56.296

SS-AI 1 MeV Dose Buildup

Dose	1	2	3	4	5	6	7	8	9	10
1	2.678	3.707	4.813	5.999	7.265	8.606	10.019	11.500	13.045	14.650
2	3.662	4.796	5.997	7.272	8.620	10.039	11.526	13.077	14.688	16.356
3	4.715	5.962	7.259	8.621	10.050	11.544	13.102	14.720	16.394	18.123
4	5.838	7.201	8.595	10.043	11.550	13.118	14.744	16.427	18.162	19.948
5	7.030	8.512	10.002	11.534	13.118	14.757	16.450	18.195	19.989	21.830
6	8.289	9.892	11.478	13.092	14.751	16.459	18.215	20.020	21.870	23.764
7	9.612	11.337	13.018	14.715	16.446	18.220	20.039	21.901	23.805	25.749
8	10.997	12.845	14.621	16.398	18.200	20.039	21.917	23.835	25.790	27.783
9	12.440	14.413	16.283	18.139	20.010	21.912	23.847	25.818	27.823	29.862
10	13.940	16.039	18.003	19.936	21.875	23.838	25.829	27.850	29.903	31.986

SS-AI 2 MeV Dose Buildup

Dose	1	2	3	4	5	6	7	8	9	10
1	2.360	3.125	3.908	4.710	5.530	6.364	7.210	8.066	8.930	9.799
2	3.117	3.906	4.709	5.529	6.363	7.210	8.066	8.931	9.801	10.674
3	3.897	4.711	5.533	6.368	7.215	8.072	8.937	9.807	10.681	11.558
4	4.701	5.540	6.378	7.226	8.083	8.948	9.819	10.693	11.570	12.447
5	5.528	6.390	7.242	8.100	8.965	9.836	10.710	11.587	12.464	13.341
6	6.376	7.258	8.123	8.989	9.860	10.734	11.611	12.488	13.365	14.238
7	7.243	8.144	9.018	9.891	10.765	11.641	12.518	13.394	14.268	15.138
8	8.127	9.044	9.926	10.803	11.679	12.555	13.431	14.304	15.174	16.040
9	9.025	9.957	10.845	11.723	12.600	13.474	14.347	15.216	16.081	16.941
10	9.936	10.882	11.773	12.652	13.526	14.398	15.266	16.130	16.988	17.841

SS-Al 6 MeV Dose Buildup

Dose	1	2	3	4	5	6	7	8	9	10
1	1.849	2.296	2.736	3.169	3.598	4.021	4.440	4.853	5.259	5.659
2	2.273	2.698	3.125	3.550	3.971	4.388	4.800	5.206	5.605	5.999
3	2.702	3.109	3.524	3.939	4.351	4.760	5.164	5.562	5.954	6.339
4	3.142	3.530	3.931	4.335	4.737	5.136	5.531	5.920	6.304	6.681
5	3.594	3.961	4.346	4.737	5.128	5.517	5.901	6.281	6.655	7.022
6	4.057	4.402	4.770	5.146	5.524	5.900	6.274	6.643	7.007	7.365
7	4.531	4.851	5.200	5.560	5.924	6.287	6.649	7.007	7.360	7.707
8	5.015	5.309	5.637	5.979	6.327	6.677	7.026	7.371	7.713	8.049
9	5.510	5.775	6.079	6.403	6.734	7.069	7.404	7.737	8.066	8.391
10	6.013	6.247	6.528	6.830	7.144	7.463	7.783	8.102	8.419	8.732

SS-Al 10 MeV Dose Buildup

Dose	1	2	3	4	5	6	7	8	9	10
1	1.654	1.986	2.312	2.634	2.953	3.268	3.581	3.890	4.195	4.497
2	1.971	2.275	2.587	2.900	3.211	3.521	3.828	4.132	4.432	4.729
3	2.294	2.575	2.872	3.175	3.478	3.781	4.082	4.380	4.675	4.966
4	2.631	2.887	3.169	3.460	3.754	4.048	4.342	4.633	4.922	5.207
5	2.982	3.213	3.477	3.755	4.039	4.324	4.609	4.893	5.174	5.453
6	3.349	3.553	3.798	4.061	4.332	4.607	4.883	5.159	5.432	5.703
7	3.733	3.907	4.131	4.378	4.635	4.899	5.164	5.430	5.695	5.958
8	4.135	4.276	4.477	4.705	4.948	5.198	5.452	5.708	5.964	6.218
9	4.554	4.659	4.835	5.043	5.269	5.506	5.747	5.992	6.237	6.482
10	4.992	5.058	5.206	5.392	5.600	5.821	6.049	6.281	6.516	6.750

Polyethylene Followed by Stainless Steel (Poly-SS)

Poly-SS 65 keV Dose Buildup

Dose	1	2	3	4	5	6	7	8	9	10
1	1.668	1.666	1.734	1.823	1.923	2.029	2.140	2.254	2.371	2.491
2	2.247	2.064	2.063	2.115	2.193	2.284	2.385	2.494	2.606	2.724
3	2.930	2.518	2.432	2.439	2.491	2.565	2.655	2.756	2.862	2.977
4	3.733	3.034	2.845	2.800	2.820	2.873	2.950	3.041	3.142	3.253
5	4.676	3.621	3.308	3.199	3.183	3.212	3.272	3.353	3.446	3.553
6	5.781	4.287	3.826	3.642	3.582	3.583	3.625	3.694	3.778	3.879
7	7.069	5.043	4.404	4.133	4.022	3.990	4.011	4.064	4.139	4.234
8	8.568	5.900	5.051	4.677	4.506	4.436	4.432	4.468	4.531	4.619
9	10.307	6.869	5.773	5.279	5.038	4.925	4.891	4.909	4.958	5.037
10	12.319	7.964	6.579	5.945	5.625	5.460	5.394	5.389	5.423	5.491

Poly-SS 100 keV Dose Buildup

Dose	1	2	3	4	5	6	7	8	9	10
1	1.908	2.079	2.300	2.543	2.800	3.072	3.358	3.658	3.973	4.303
2	2.548	2.567	2.724	2.931	3.168	3.427	3.705	4.000	4.314	4.644
3	3.270	3.103	3.183	3.349	3.560	3.804	4.071	4.362	4.672	5.002
4	4.090	3.692	3.681	3.798	3.979	4.203	4.459	4.741	5.048	5.376
5	5.024	4.342	4.222	4.280	4.426	4.627	4.868	5.140	5.442	5.767
6	6.086	5.060	4.809	4.798	4.902	5.077	5.300	5.562	5.854	6.175
7	7.294	5.852	5.447	5.356	5.411	5.554	5.755	6.003	6.286	6.602
8	8.663	6.725	6.139	5.955	5.953	6.060	6.237	6.466	6.740	7.048
9	10.212	7.688	6.892	6.599	6.532	6.597	6.745	6.956	7.215	7.514
10	11.961	8.747	7.708	7.291	7.150	7.166	7.281	7.468	7.712	8.000

Poly-SS 500 keV Dose Buildup

Dose	1	2	3	4	5	6	7	8	9	10
1	2.689	3.612	4.619	5.716	6.906	8.191	9.574	11.058	12.643	14.331
2	3.652	4.620	5.693	6.862	8.128	9.492	10.954	12.518	14.185	15.955
3	4.714	5.722	6.857	8.096	9.436	10.876	12.416	14.059	15.806	17.657
4	5.882	6.920	8.112	9.418	10.830	12.344	13.960	15.681	17.506	19.437
5	7.162	8.218	9.462	10.830	12.310	13.896	15.586	17.382	19.285	21.294
6	8.556	9.618	10.905	12.332	13.877	15.532	17.294	19.164	21.143	23.229
7	10.066	11.119	12.444	13.924	15.530	17.252	19.084	21.026	23.079	25.241
8	11.693	12.723	14.078	15.606	17.270	19.056	20.955	22.968	25.094	27.328
9	13.437	14.430	15.806	17.376	19.091	20.947	22.910	24.989	27.182	29.488
10	15.298	16.236	17.637	19.245	21.012	22.913	24.938	27.083	29.362	31.741

Poly-SS 1 MeV Dose Buildup

Dose	1	2	3	4	5	6	7	8	9	10
1	2.558	3.451	4.403	5.414	6.485	7.612	8.794	10.029	11.313	12.647
2	3.462	4.399	5.403	6.466	7.587	8.762	9.991	11.270	12.597	13.971
3	4.427	5.406	6.457	7.569	8.737	9.958	11.231	12.551	13.918	15.329
4	5.453	6.469	7.565	8.722	9.934	11.197	12.510	13.869	15.273	16.720
5	6.540	7.587	8.722	9.920	11.173	12.476	13.826	15.222	16.660	18.140
6	7.684	8.756	9.927	11.162	12.452	13.793	15.175	16.606	18.079	19.583
7	8.884	9.972	11.175	12.447	13.767	15.143	16.564	18.019	19.522	21.063
8	10.133	11.234	12.465	13.768	15.119	16.526	17.977	19.461	20.992	22.559
9	11.430	12.540	13.795	15.125	16.505	17.941	19.420	20.930	22.486	24.078
10	12.771	13.885	15.160	16.515	17.921	19.382	20.887	22.421	24.001	25.615

Poly-SS 2 MeV Dose Buildup

Dose	1	2	3	4	5	6	7	8	9	10
1	2.321	3.051	3.800	4.571	5.363	6.174	7.002	7.846	8.702	9.571
2	3.050	3.800	4.571	5.363	6.174	7.002	7.845	8.702	9.570	10.449
3	3.790	4.561	5.354	6.165	6.993	7.837	8.693	9.561	10.439	11.325
4	4.543	5.333	6.145	6.974	7.817	8.674	9.542	10.420	11.306	12.199
5	5.306	6.114	6.943	7.788	8.646	9.515	10.393	11.280	12.173	13.071
6	6.078	6.901	7.747	8.606	9.476	10.355	11.242	12.136	13.034	13.936
7	6.857	7.694	8.553	9.424	10.305	11.193	12.088	12.987	13.890	14.795
8	7.640	8.489	9.360	10.242	11.133	12.029	12.930	13.834	14.740	15.647
9	8.426	9.285	10.167	11.059	11.957	12.860	13.766	14.673	15.582	16.490
10	9.213	10.080	10.972	11.872	12.777	13.685	14.595	15.505	16.415	17.324

Poly-SS 6 MeV Dose Buildup

Dose	1	2	3	4	5	6	7	8	9	10
1	1.978	2.454	2.931	3.417	3.916	4.426	4.948	5.482	6.027	6.581
2	2.488	2.992	3.495	4.006	4.527	5.059	5.602	6.153	6.715	7.283
3	2.969	3.504	4.036	4.573	5.116	5.670	6.231	6.801	7.379	7.962
4	3.428	3.997	4.557	5.119	5.685	6.260	6.841	7.426	8.020	8.617
5	3.869	4.471	5.059	5.646	6.235	6.829	7.426	8.030	8.638	9.249
6	4.294	4.928	5.543	6.154	6.764	7.377	7.992	8.612	9.235	9.858
7	4.703	5.369	6.010	6.644	7.274	7.906	8.537	9.172	9.809	10.445
8	5.097	5.793	6.460	7.116	7.766	8.415	9.063	9.712	10.362	11.010
9	5.477	6.201	6.893	7.570	8.239	8.906	9.571	10.232	10.895	11.555
10	5.842	6.595	7.309	8.007	8.694	9.378	10.058	10.733	11.408	12.079

Poly-SS 10 MeV Dose Buildup

Dose	1	2	3	4	5	6	7	8	9	10
1	1.850	2.252	2.654	3.068	3.498	3.948	4.417	4.908	5.421	5.955
2	2.270	2.712	3.153	3.606	4.075	4.564	5.072	5.603	6.155	6.729
3	2.656	3.140	3.621	4.113	4.621	5.147	5.694	6.263	6.852	7.464
4	3.017	3.544	4.064	4.594	5.139	5.702	6.285	6.890	7.516	8.164
5	3.359	3.926	4.484	5.050	5.631	6.229	6.847	7.487	8.148	8.831
6	3.683	4.289	4.884	5.485	6.100	6.732	7.383	8.057	8.750	9.466
7	3.991	4.635	5.265	5.899	6.546	7.210	7.894	8.599	9.325	10.073
8	4.284	4.965	5.627	6.293	6.972	7.667	8.381	9.117	9.873	10.651
9	4.563	5.279	5.973	6.670	7.378	8.102	8.845	9.611	10.396	11.204
10	4.830	5.578	6.303	7.028	7.765	8.518	9.289	10.082	10.895	11.731

Stainless Steel Followed by Polyethylene (SS-Poly)

SS-Poly 65 keV Dose Buildup

Dose	1	2	3	4	5	6	7	8	9	10
1	3.004	6.018	10.672	17.379	26.657	39.114	55.454	76.480	103.117	136.416
2	3.306	6.585	11.635	18.898	28.924	42.362	59.959	82.572	111.179	146.898
3	3.591	7.127	12.564	20.369	31.129	45.531	64.368	88.546	119.103	157.219
4	3.871	7.662	13.481	21.826	33.316	48.679	68.753	94.495	127.002	167.518
5	4.149	8.195	14.398	23.284	35.507	51.835	73.153	100.469	134.938	177.871
6	4.427	8.730	15.320	24.750	37.711	55.012	77.584	106.489	142.939	188.314
7	4.708	9.269	16.249	26.230	39.937	58.222	82.063	112.575	151.030	198.876
8	4.991	9.814	17.189	27.727	42.189	61.471	86.598	118.738	159.227	209.579
9	5.277	10.365	18.139	29.240	44.468	64.759	91.188	124.978	167.527	220.417
10	5.567	10.924	19.104	30.778	46.783	68.100	95.852	131.320	175.963	231.438

SS-Poly 100 keV Dose Buildup

Dose	1	2	3	4	5	6	7	8	9	10
1	3.107	6.279	11.370	18.963	29.770	44.629	64.504	90.499	123.867	166.022
2	3.707	7.371	13.236	21.950	34.301	51.217	73.766	103.164	140.788	188.193
3	4.282	8.436	15.072	24.904	38.800	57.785	83.030	115.869	157.810	210.552
4	4.858	9.511	16.933	27.907	43.386	64.492	92.508	128.889	175.278	233.523
5	5.444	10.612	18.844	30.994	48.107	71.406	102.287	142.334	193.331	257.285
6	6.048	11.750	20.822	34.194	53.003	78.580	112.439	156.298	212.091	281.987
7	6.674	12.933	22.878	37.521	58.097	86.046	123.010	170.843	231.638	307.731
8	7.325	14.162	25.019	40.989	63.407	93.834	134.038	186.022	252.042	334.610
9	8.004	15.446	27.254	44.609	68.954	101.969	145.560	201.886	273.366	362.709
10	8.711	16.786	29.587	48.391	74.749	110.468	157.601	218.463	295.653	392.079

SS-Poly 500 keV Dose Buildup

Dose	1	2	3	4	5	6	7	8	9	10
1	3.051	4.672	6.708	9.163	12.049	15.379	19.162	23.411	28.133	33.336
2	4.232	6.255	8.762	11.726	15.143	19.018	23.358	28.171	33.465	39.245
3	5.526	8.006	11.037	14.559	18.556	23.020	27.956	33.369	39.266	45.658
4	6.945	9.931	13.537	17.670	22.292	27.391	32.962	39.011	45.544	52.572
5	8.495	12.036	16.268	21.061	26.358	32.134	38.381	45.102	52.303	59.998
6	10.179	14.323	19.234	24.738	30.758	37.255	44.219	51.649	59.555	67.941
7	12.000	16.796	22.438	28.705	35.495	42.759	50.479	58.655	67.296	76.408
8	13.960	19.458	25.884	32.966	40.577	48.653	57.171	66.130	75.539	85.408
9	16.062	22.312	29.575	37.526	46.007	54.941	64.300	74.081	84.291	94.956
10	18.309	25.361	33.516	42.387	51.789	61.628	71.870	82.509	93.558	105.043

SS-Poly 1 MeV Dose Buildup

Dose	1	2	3	4	5	6	7	8	9	10
1	2.743	3.943	5.274	6.724	8.288	9.960	11.735	13.605	15.566	17.610
2	3.776	5.168	6.672	8.272	9.969	11.761	13.645	15.617	17.674	19.808
3	4.883	6.486	8.171	9.925	11.755	13.664	15.655	17.726	19.874	22.094
4	6.067	7.894	9.768	11.678	13.639	15.664	17.760	19.926	22.162	24.464
5	7.326	9.389	11.457	13.525	15.618	17.757	19.953	22.211	24.533	26.913
6	8.657	10.965	13.234	15.462	17.686	19.937	22.232	24.579	26.983	29.439
7	10.058	12.622	15.096	17.485	19.840	22.201	24.593	27.027	29.510	32.038
8	11.525	14.353	17.038	19.591	22.076	24.546	27.031	29.549	32.107	34.705
9	13.055	16.156	19.057	21.774	24.389	26.967	29.544	32.142	34.774	37.438
10	14.647	18.029	21.149	24.033	26.778	29.460	32.129	34.806	37.508	40.236

SS-Poly 2 MeV Dose Buildup

Dose	1	2	3	4	5	6	7	8	9	10
1	2.392	3.215	4.051	4.903	5.770	6.650	7.540	8.436	9.337	10.241
2	3.172	4.038	4.900	5.769	6.649	7.539	8.436	9.338	10.242	11.147
3	3.976	4.889	5.774	6.658	7.549	8.446	9.348	10.252	11.157	12.061
4	4.807	5.766	6.673	7.568	8.466	9.368	10.272	11.176	12.080	12.981
5	5.661	6.666	7.592	8.496	9.399	10.302	11.206	12.109	13.009	13.905
6	6.538	7.587	8.530	9.440	10.345	11.248	12.149	13.049	13.944	14.834
7	7.435	8.526	9.484	10.399	11.303	12.203	13.100	13.994	14.882	15.764
8	8.349	9.482	10.452	11.369	12.270	13.166	14.057	14.943	15.823	16.696
9	9.279	10.452	11.432	12.348	13.245	14.134	15.017	15.894	16.765	17.627
10	10.223	11.434	12.423	13.336	14.227	15.107	15.981	16.848	17.707	18.558

SS-Poly 6 MeV Dose Buildup

Dose	1	2	3	4	5	6	7	8	9	10
1	1.826	2.269	2.694	3.102	3.495	3.873	4.238	4.589	4.927	5.253
2	2.223	2.627	3.027	3.416	3.793	4.158	4.509	4.848	5.175	5.490
3	2.625	2.992	3.366	3.735	4.095	4.444	4.782	5.108	5.423	5.727
4	3.037	3.364	3.710	4.057	4.398	4.731	5.055	5.368	5.671	5.963
5	3.459	3.744	4.060	4.383	4.705	5.020	5.328	5.627	5.917	6.197
6	3.891	4.132	4.415	4.713	5.013	5.310	5.602	5.886	6.162	6.430
7	4.333	4.526	4.774	5.045	5.323	5.601	5.875	6.144	6.407	6.662
8	4.785	4.927	5.138	5.380	5.634	5.892	6.149	6.402	6.650	6.891
9	5.245	5.334	5.506	5.718	5.947	6.183	6.422	6.659	6.892	7.120
10	5.713	5.746	5.877	6.057	6.260	6.475	6.694	6.914	7.132	7.347

SS-Poly 10 MeV Dose Buildup

Dose	1	2	3	4	5	6	7	8	9	10
1	1.599	1.927	2.237	2.530	2.809	3.073	3.325	3.566	3.795	4.013
2	1.870	2.153	2.438	2.714	2.978	3.232	3.474	3.705	3.926	4.137
3	2.147	2.385	2.644	2.902	3.151	3.392	3.624	3.845	4.057	4.260
4	2.435	2.626	2.857	3.094	3.328	3.555	3.775	3.987	4.190	4.384
5	2.734	2.876	3.076	3.291	3.507	3.721	3.928	4.129	4.323	4.509
6	3.046	3.136	3.302	3.493	3.691	3.888	4.083	4.273	4.456	4.634
7	3.372	3.404	3.534	3.699	3.877	4.059	4.240	4.418	4.591	4.759
8	3.712	3.682	3.774	3.911	4.067	4.232	4.398	4.564	4.726	4.884
9	4.065	3.970	4.020	4.127	4.261	4.407	4.559	4.711	4.862	5.010
10	4.434	4.268	4.273	4.349	4.458	4.585	4.720	4.859	4.999	5.137

Appendix 2: Exposure Buildup Factors

The following tables present the exposure buildup factors calculated in PARTISN for various materials and energies. In each table, the first material thicknesses increase along the rows, the second material thicknesses increase along columns. For example, column 2 shows fractional differences for shields with 2 mfp of the first material followed by 1-10 mfp of the second material.

Aluminum Followed by Lead

Al-Pb 65 keV Exposure Buildup

Exposure	1	2	3	4	5	6	7	8	9	10
1	1.770	1.796	1.867	1.953	2.047	2.144	2.244	2.345	2.446	2.550
2	2.226	2.167	2.200	2.266	2.347	2.436	2.531	2.629	2.730	2.833
3	2.721	2.575	2.567	2.611	2.678	2.759	2.848	2.942	3.039	3.143
4	3.263	3.025	2.973	2.991	3.042	3.113	3.195	3.285	3.380	3.482
5	3.860	3.522	3.421	3.410	3.443	3.502	3.577	3.661	3.753	3.854
6	4.519	4.069	3.914	3.871	3.884	3.929	3.995	4.073	4.163	4.261
7	5.248	4.677	4.462	4.385	4.377	4.391	4.447	4.521	4.608	4.705
8	6.049	5.342	5.059	4.942	4.909	4.903	4.949	5.014	5.097	5.193
9	6.933	6.075	5.717	5.555	5.493	5.466	5.498	5.557	5.633	5.727
10	7.908	6.881	6.439	6.228	6.134	6.083	6.101	6.149	6.221	6.312

Al-Pb 100 keV Exposure Buildup

Exposure	1	2	3	4	5	6	7	8	9	10
1	3.259	4.080	5.243	6.952	9.536	13.555	19.956	30.362	47.577	76.499
2	4.602	5.664	7.287	9.786	13.693	19.938	30.115	46.994	75.424	123.963
3	6.122	7.513	9.737	13.263	18.901	28.082	43.283	68.847	112.435	187.674
4	7.842	9.645	12.608	17.397	25.175	38.005	59.484	95.956	158.678	267.758
5	9.783	12.074	15.910	22.186	32.627	49.858	78.936	128.648	214.647	364.993
6	11.977	14.849	19.718	27.766	41.260	63.698	101.794	167.274	281.086	480.879
7	14.445	17.990	24.060	34.167	51.218	79.738	128.395	212.379	358.894	616.941
8	17.212	21.532	28.982	41.463	62.619	98.175	159.072	264.541	449.089	774.979
9	20.306	25.510	34.536	49.731	75.590	119.220	194.186	324.388	552.778	956.972
10	23.755	29.963	40.780	59.061	90.277	143.117	234.154	392.645	671.240	1165.190

Al-Pb 500 keV Exposure Buildup

Exposure	1	2	3	4	5	6	7	8	9	10
1	1.652	1.806	1.978	2.156	2.339	2.526	2.716	2.911	3.109	3.311
2	2.056	2.117	2.240	2.388	2.549	2.719	2.897	3.080	3.268	3.462
3	2.477	2.438	2.511	2.626	2.764	2.917	3.080	3.252	3.431	3.615
4	2.918	2.771	2.790	2.871	2.985	3.119	3.267	3.427	3.595	3.771
5	3.382	3.117	3.077	3.122	3.210	3.326	3.459	3.605	3.762	3.929
6	3.870	3.477	3.374	3.379	3.441	3.536	3.652	3.786	3.932	4.089
7	4.382	3.849	3.680	3.644	3.677	3.751	3.851	3.970	4.105	4.251
8	4.919	4.237	3.995	3.916	3.918	3.969	4.053	4.158	4.280	4.416
9	5.482	4.638	4.320	4.195	4.166	4.193	4.258	4.349	4.459	4.584
10	6.070	5.054	4.655	4.481	4.419	4.423	4.468	4.543	4.640	4.754

Al-Pb 1 MeV Exposure Buildup

Exposure	1	2	3	4	5	6	7	8	9	10
1	1.838	2.144	2.451	2.758	3.064	3.373	3.685	4.000	4.319	4.641
2	2.320	2.554	2.824	3.106	3.396	3.693	3.995	4.302	4.614	4.930
3	2.814	2.974	3.203	3.460	3.733	4.016	4.307	4.606	4.911	5.221
4	3.323	3.403	3.591	3.821	4.074	4.343	4.623	4.912	5.209	5.513
5	3.849	3.843	3.985	4.186	4.419	4.673	4.941	5.220	5.509	5.805
6	4.391	4.292	4.387	4.558	4.769	5.006	5.261	5.530	5.810	6.099
7	4.949	4.752	4.796	4.934	5.122	5.342	5.584	5.841	6.112	6.392
8	5.523	5.222	5.212	5.315	5.479	5.681	5.908	6.154	6.414	6.686
9	6.112	5.701	5.634	5.701	5.840	6.022	6.234	6.468	6.717	6.981
10	6.715	6.188	6.062	6.092	6.204	6.366	6.562	6.782	7.021	7.275

Al-Pb 2 MeV Exposure Buildup

Exposure	1	2	3	4	5	6	7	8	9	10
1	1.930	2.326	2.724	3.126	3.533	3.947	4.366	4.793	5.226	5.665
2	2.458	2.826	3.214	3.612	4.019	4.433	4.855	5.284	5.720	6.162
3	2.989	3.330	3.708	4.101	4.507	4.922	5.346	5.777	6.214	6.659
4	3.526	3.839	4.205	4.594	4.998	5.413	5.837	6.269	6.709	7.155
5	4.068	4.353	4.706	5.090	5.491	5.905	6.329	6.762	7.202	7.649
6	4.617	4.870	5.210	5.587	5.985	6.397	6.820	7.253	7.694	8.141
7	5.170	5.390	5.716	6.085	6.478	6.888	7.310	7.743	8.183	8.631
8	5.726	5.912	6.222	6.583	6.971	7.378	7.799	8.230	8.669	9.117
9	6.285	6.435	6.728	7.080	7.463	7.866	8.284	8.714	9.152	9.599
10	6.846	6.959	7.234	7.575	7.952	8.352	8.767	9.196	9.630	10.077

Al-Pb 6 MeV Exposure Buildup

Exposure	1	2	3	4	5	6	7	8	9	10
1	1.811	2.147	2.508	2.902	3.332	3.803	4.320	4.887	5.511	6.196
2	2.284	2.668	3.086	3.543	4.044	4.594	5.197	5.858	6.585	7.383
3	2.744	3.181	3.659	4.182	4.755	5.384	6.074	6.831	7.662	8.575
4	3.198	3.688	4.227	4.817	5.463	6.172	6.950	7.803	8.739	9.765
5	3.646	4.191	4.791	5.447	6.167	6.956	7.821	8.770	9.810	10.952
6	4.089	4.689	5.349	6.072	6.865	7.734	8.686	9.731	10.872	12.128
7	4.527	5.181	5.902	6.692	7.555	8.503	9.543	10.683	11.927	13.295
8	4.960	5.668	6.446	7.301	8.239	9.266	10.387	11.620	12.971	14.452
9	5.386	6.147	6.983	7.904	8.912	10.017	11.227	12.548	14.000	15.592
10	5.805	6.618	7.513	8.497	9.575	10.756	12.050	13.462	15.014	16.715

Al-Pb 10 MeV Exposure Buildup

Exposure	1	2	3	4	5	6	7	8	9	10
1	1.815	2.206	2.641	3.143	3.728	4.450	5.276	6.257	7.427	8.825
2	2.224	2.692	3.222	3.838	4.562	5.418	6.484	7.711	9.177	10.933
3	2.618	3.166	3.792	4.524	5.387	6.412	7.632	9.090	10.927	13.046
4	3.003	3.633	4.356	5.205	6.208	7.401	8.826	10.531	12.576	15.034
5	3.384	4.095	4.915	5.880	7.024	8.386	10.015	11.968	14.314	17.136
6	3.760	4.552	5.471	6.551	7.834	9.364	11.202	13.401	16.046	19.230
7	4.132	5.005	6.021	7.217	8.639	10.338	12.380	14.826	17.770	21.318
8	4.500	5.454	6.566	7.877	9.438	11.304	13.550	16.242	19.485	23.394
9	4.865	5.898	7.105	8.530	10.229	12.262	14.709	17.647	21.185	25.455
10	5.224	6.337	7.638	9.177	11.012	13.211	15.859	19.039	22.872	27.499

Lead Followed by Aluminum

Pb-Al 65 keV Exposure Buildup

Exposure	1	2	3	4	5	6	7	8	9	10
1	1.914	2.621	3.351	4.135	4.990	5.930	6.966	8.107	9.367	10.757
2	2.060	2.805	3.572	4.395	5.290	6.273	7.355	8.547	9.861	11.309
3	2.202	2.986	3.791	4.652	5.589	6.616	7.744	8.986	10.355	11.862
4	2.341	3.165	4.009	4.909	5.887	6.958	8.134	9.427	10.850	12.417
5	2.480	3.344	4.227	5.167	6.187	7.302	8.525	9.869	11.348	12.976
6	2.619	3.523	4.445	5.425	6.487	7.647	8.918	10.313	11.848	13.536
7	2.758	3.703	4.664	5.685	6.789	7.994	9.313	10.762	12.353	14.103
8	2.897	3.884	4.884	5.946	7.093	8.343	9.712	11.213	12.862	14.673
9	3.037	4.065	5.106	6.209	7.399	8.696	10.114	11.668	13.375	15.250
10	3.178	4.248	5.329	6.474	7.708	9.051	10.519	12.128	13.893	15.832

Pb-Al 100 keV Exposure Buildup

Exposure	1	2	3	4	5	6	7	8	9	10
1	2.339	3.357	4.486	5.754	7.184	8.796	10.607	12.638	14.908	17.438
2	2.904	3.878	4.977	6.226	7.645	9.253	11.067	13.106	15.390	17.940
3	3.692	4.621	5.680	6.896	8.290	9.881	11.686	13.723	16.010	18.570
4	4.852	5.737	6.741	7.907	9.258	10.814	12.591	14.609	16.884	19.439
5	6.618	7.473	8.409	9.501	10.783	12.278	14.003	15.976	18.217	20.745
6	9.389	10.249	11.105	12.096	13.275	14.671	16.307	18.200	20.371	22.838
7	13.836	14.785	15.564	16.423	17.454	18.702	20.195	21.955	24.001	26.355
8	21.109	22.329	23.070	23.775	24.605	25.636	26.910	28.456	30.297	32.457
9	33.198	35.065	35.887	36.443	37.019	37.746	38.695	39.911	41.422	43.258
10	53.581	56.840	58.041	58.533	58.823	59.147	59.629	60.343	61.334	62.644

Pb-Al 500 keV Exposure Buildup

Exposure	1	2	3	4	5	6	7	8	9	10
1	2.319	3.438	4.689	6.089	7.650	9.375	11.271	13.340	15.585	18.009
2	2.699	3.940	5.321	6.861	8.568	10.450	12.509	14.751	17.175	19.787
3	3.051	4.417	5.930	7.610	9.467	11.506	13.732	16.148	18.756	21.559
4	3.393	4.885	6.531	8.353	10.360	12.559	14.955	17.548	20.343	23.340
5	3.731	5.351	7.132	9.097	11.257	13.619	16.186	18.960	21.944	25.139
6	4.069	5.818	7.736	9.847	12.163	14.690	17.431	20.389	23.565	26.963
7	4.409	6.289	8.346	10.605	13.079	15.773	18.692	21.838	25.211	28.813
8	4.752	6.766	8.964	11.374	14.008	16.874	19.973	23.310	26.883	30.695
9	5.100	7.249	9.591	12.154	14.952	17.991	21.276	24.806	28.584	32.609
10	5.453	7.741	10.228	12.947	15.912	19.128	22.600	26.329	30.314	34.557

Pb-Al 1 MeV Exposure Buildup

Exposure	1	2	3	4	5	6	7	8	9	10
1	2.314	3.291	4.330	5.439	6.619	7.866	9.177	10.550	11.981	13.466
2	2.840	3.931	5.077	6.288	7.565	8.906	10.309	11.769	13.285	14.852
3	3.336	4.548	5.806	7.124	8.503	9.942	11.438	12.990	14.594	16.247
4	3.818	5.154	6.528	7.955	9.439	10.978	12.573	14.218	15.913	17.654
5	4.295	5.757	7.249	8.787	10.378	12.021	13.715	15.457	17.245	19.076
6	4.770	6.361	7.972	9.625	11.325	13.073	14.869	16.709	18.591	20.514
7	5.248	6.969	8.701	10.469	12.281	14.136	16.035	17.975	19.953	21.969
8	5.729	7.582	9.437	11.323	13.247	15.211	17.215	19.256	21.333	23.443
9	6.214	8.200	10.180	12.185	14.224	16.299	18.409	20.553	22.730	24.936
10	6.704	8.826	10.933	13.059	15.214	17.401	19.619	21.868	24.146	26.450

Pb-Al 2 MeV Exposure Buildup

Exposure	1	2	3	4	5	6	7	8	9	10
1	2.162	2.916	3.678	4.455	5.247	6.052	6.868	7.693	8.525	9.362
2	2.686	3.492	4.293	5.101	5.918	6.745	7.579	8.420	9.265	10.114
3	3.203	4.068	4.913	5.754	6.599	7.448	8.301	9.158	10.016	10.876
4	3.720	4.650	5.541	6.418	7.290	8.162	9.034	9.906	10.778	11.648
5	4.243	5.240	6.178	7.091	7.993	8.887	9.778	10.665	11.549	12.430
6	4.773	5.838	6.825	7.776	8.705	9.623	10.532	11.434	12.330	13.221
7	5.311	6.446	7.483	8.470	9.429	10.369	11.296	12.213	13.121	14.020
8	5.857	7.064	8.151	9.176	10.164	11.127	12.071	13.002	13.921	14.829
9	6.412	7.691	8.829	9.892	10.908	11.893	12.855	13.800	14.729	15.644
10	6.976	8.328	9.517	10.618	11.663	12.670	13.649	14.607	15.546	16.469

Pb-Al 6 MeV Exposure Buildup

Exposure	1	2	3	4	5	6	7	8	9	10
1	1.680	2.115	2.542	2.963	3.380	3.792	4.199	4.602	4.998	5.389
2	1.960	2.374	2.787	3.198	3.607	4.013	4.415	4.811	5.203	5.588
3	2.259	2.652	3.049	3.448	3.848	4.245	4.640	5.029	5.414	5.793
4	2.583	2.952	3.330	3.715	4.102	4.490	4.875	5.257	5.634	6.005
5	2.935	3.277	3.632	3.999	4.372	4.747	5.122	5.494	5.862	6.226
6	3.319	3.629	3.957	4.303	4.658	5.019	5.381	5.742	6.100	6.454
7	3.738	4.011	4.308	4.628	4.963	5.306	5.653	6.000	6.347	6.690
8	4.197	4.426	4.685	4.975	5.286	5.609	5.939	6.271	6.604	6.935
9	4.700	4.878	5.093	5.348	5.630	5.929	6.240	6.555	6.873	7.191
10	5.250	5.368	5.533	5.747	5.996	6.269	6.557	6.853	7.154	7.457

Pb-Al 10 MeV Exposure Buildup

Exposure	1	2	3	4	5	6	7	8	9	10
1	1.547	1.857	2.168	2.478	2.786	3.092	3.395	3.696	3.993	4.288
2	1.793	2.056	2.341	2.635	2.933	3.231	3.528	3.823	4.115	4.405
3	2.071	2.282	2.536	2.811	3.095	3.382	3.671	3.960	4.246	4.531
4	2.391	2.541	2.758	3.008	3.274	3.549	3.828	4.108	4.387	4.665
5	2.762	2.839	3.010	3.229	3.474	3.733	3.999	4.268	4.539	4.809
6	3.196	3.185	3.298	3.479	3.697	3.936	4.187	4.444	4.703	4.965
7	3.707	3.588	3.630	3.764	3.949	4.163	4.395	4.636	4.883	5.133
8	4.308	4.058	4.013	4.088	4.232	4.416	4.624	4.847	5.079	5.316
9	5.020	4.610	4.457	4.460	4.553	4.700	4.880	5.080	5.293	5.515
10	5.864	5.258	4.973	4.887	4.918	5.020	5.165	5.338	5.529	5.733

Polyethylene Followed by Lead

Poly-Pb 65 keV Exposure Buildup Factors

Exposure	1	2	3	4	5	6	7	8	9	10
1	1.904	1.841	1.879	1.946	2.027	2.116	2.208	2.303	2.401	2.500
2	2.596	2.288	2.236	2.258	2.312	2.373	2.453	2.539	2.630	2.726
3	3.427	2.798	2.637	2.603	2.622	2.660	2.725	2.800	2.883	2.973
4	4.418	3.383	3.087	2.986	2.966	2.976	3.023	3.085	3.159	3.243
5	5.596	4.051	3.592	3.411	3.344	3.323	3.348	3.396	3.460	3.536
6	6.991	4.813	4.159	3.884	3.762	3.703	3.705	3.736	3.788	3.856
7	8.634	5.681	4.794	4.408	4.222	4.121	4.095	4.106	4.145	4.203
8	10.564	6.669	5.505	4.989	4.709	4.579	4.520	4.510	4.534	4.581
9	12.820	7.790	6.301	5.634	5.288	5.080	4.986	4.951	4.957	4.991
10	15.448	9.062	7.190	6.348	5.904	5.631	5.494	5.430	5.416	5.436

Poly-Pb 100 keV Exposure Buildup Factors

Exposure	1	2	3	4	5	6	7	8	9	10
1	3.530	4.316	5.504	7.290	10.022	14.304	21.158	32.347	50.925	82.234
2	5.541	6.484	8.218	11.012	15.538	22.780	34.675	54.518	88.100	145.661
3	8.177	9.295	11.784	15.988	22.974	34.379	53.407	85.577	140.653	236.025
4	11.549	12.827	16.276	22.302	32.481	49.312	77.671	126.013	209.370	354.614
5	15.794	17.183	21.809	30.103	44.274	67.909	107.985	176.674	295.667	503.849
6	21.066	22.483	28.518	39.572	58.617	90.571	144.996	238.622	401.331	686.783
7	27.539	28.859	36.555	50.912	75.807	117.759	189.436	313.063	528.388	906.882
8	35.407	36.462	46.091	64.351	96.179	149.985	242.128	401.353	679.117	1168.030
9	44.886	45.457	57.312	80.137	120.094	187.810	303.969	504.957	855.979	1474.440
10	56.215	56.024	70.422	98.542	147.950	231.843	375.925	625.469	1061.640	1830.650

Poly-Pb 500 keV Exposure Buildup Factors

Exposure	1	2	3	4	5	6	7	8	9	10
1	1.644	1.797	1.969	2.146	2.328	2.514	2.704	2.898	3.096	3.297
2	2.039	2.098	2.221	2.367	2.527	2.695	2.871	3.053	3.241	3.433
3	2.447	2.408	2.479	2.593	2.729	2.880	3.041	3.211	3.387	3.570
4	2.873	2.726	2.744	2.823	2.934	3.066	3.213	3.370	3.536	3.709
5	3.319	3.055	3.015	3.058	3.144	3.257	3.387	3.531	3.685	3.849
6	3.785	3.395	3.293	3.297	3.357	3.449	3.563	3.694	3.837	3.990
7	4.272	3.746	3.578	3.542	3.573	3.644	3.742	3.859	3.990	4.133
8	4.780	4.108	3.871	3.792	3.794	3.843	3.923	4.026	4.145	4.278
9	5.310	4.482	4.171	4.045	4.022	4.047	4.107	4.193	4.298	4.426
10	5.858	4.863	4.482	4.310	4.248	4.249	4.291	4.370	4.462	4.571

Poly-Pb 1 MeV Exposure Buildup Factors

Exposure	1	2	3	4	5	6	7	8	9	10
1	1.836	2.141	2.448	2.754	3.060	3.369	3.680	3.995	4.313	4.635
2	2.313	2.547	2.816	3.097	3.387	3.683	3.984	4.290	4.602	4.918
3	2.802	2.961	3.190	3.446	3.718	4.000	4.290	4.588	4.891	5.201
4	3.305	3.385	3.571	3.800	4.052	4.319	4.598	4.886	5.182	5.484
5	3.824	3.817	3.958	4.158	4.390	4.641	4.908	5.186	5.473	5.768
6	4.357	4.258	4.352	4.521	4.730	4.966	5.219	5.486	5.763	6.051
7	4.906	4.710	4.749	4.886	5.074	5.293	5.533	5.789	6.054	6.334
8	5.468	5.168	5.154	5.257	5.420	5.621	5.847	6.091	6.345	6.616
9	6.043	5.635	5.564	5.632	5.770	5.951	6.162	6.394	6.637	6.899
10	6.631	6.109	5.979	6.009	6.121	6.282	6.477	6.696	6.928	7.181

Poly-Pb 2 MeV Exposure Buildup Factors

Exposure	1	2	3	4	5	6	7	8	9	10
1	1.933	2.329	2.727	3.128	3.536	3.949	4.369	4.795	5.228	5.667
2	2.460	2.829	3.216	3.615	4.021	4.436	4.858	5.287	5.722	6.164
3	2.988	3.331	3.708	4.102	4.508	4.923	5.346	5.777	6.215	6.659
4	3.518	3.834	4.201	4.591	4.995	5.410	5.834	6.268	6.705	7.152
5	4.053	4.340	4.696	5.081	5.481	5.897	6.319	6.753	7.195	7.639
6	4.590	4.847	5.190	5.570	5.967	6.381	6.803	7.237	7.679	8.124
7	5.129	5.354	5.685	6.057	6.450	6.863	7.284	7.717	8.159	8.604
8	5.668	5.862	6.178	6.542	6.931	7.341	7.760	8.194	8.635	9.080
9	6.208	6.367	6.668	7.025	7.409	7.816	8.233	8.665	9.106	9.550
10	6.746	6.871	7.156	7.504	7.882	8.286	8.701	9.131	9.571	10.014

Poly-Pb 6 MeV Exposure Buildup Factors

Exposure	1	2	3	4	5	6	7	8	9	10
1	1.856	2.200	2.569	2.970	3.410	3.891	4.419	4.998	5.635	6.335
2	2.351	2.749	3.181	3.653	4.170	4.736	5.358	6.040	6.789	7.612
3	2.818	3.273	3.767	4.310	4.904	5.555	6.270	7.051	7.911	8.854
4	3.264	3.775	4.333	4.944	5.613	6.347	7.151	8.030	8.998	10.059
5	3.692	4.259	4.878	5.556	6.299	7.113	8.005	8.979	10.051	11.227
6	4.104	4.726	5.404	6.147	6.961	7.852	8.829	9.895	11.069	12.356
7	4.501	5.176	5.911	6.717	7.600	8.566	9.621	10.781	12.053	13.446
8	4.882	5.607	6.396	7.263	8.211	9.249	10.381	11.627	12.992	14.487
9	5.251	6.024	6.867	7.792	8.804	9.912	11.121	12.450	13.907	15.502
10	5.605	6.426	7.321	8.302	9.376	10.552	11.839	13.244	14.788	16.480

Poly-Pb 10 MeV Exposure Buildup Factors

Exposure	1	2	3	4	5	6	7	8	9	10
1	1.878	2.282	2.734	3.255	3.863	4.580	5.429	6.438	7.641	9.080
2	2.315	2.805	3.362	4.008	4.767	5.665	6.736	8.010	9.533	11.358
3	2.716	3.290	3.947	4.712	5.614	6.684	7.964	9.489	11.316	13.509
4	3.091	3.746	4.497	5.375	6.413	7.647	9.125	10.888	13.004	15.547
5	3.445	4.177	5.019	6.004	7.171	8.561	10.226	12.217	14.607	17.482
6	3.781	4.586	5.514	6.602	7.892	9.429	11.273	13.480	16.131	19.323
7	4.100	4.975	5.985	7.171	8.578	10.256	12.271	14.683	17.583	21.075
8	4.404	5.346	6.434	7.713	9.231	11.043	13.220	15.828	18.965	22.745
9	4.694	5.699	6.862	8.229	9.854	11.794	14.126	16.920	20.284	24.337
10	4.970	6.036	7.270	8.721	10.447	12.510	14.989	17.962	21.541	25.855

Lead Followed by Polyethylene (Poly-Pb)

Pb-Poly 65 keV Exposure Buildup Factors

Exposure	1	2	3	4	5	6	7	8	9	10
1	2.997	6.453	12.151	20.713	32.914	49.673	72.053	101.277	138.747	186.068
2	3.229	6.927	13.016	22.151	35.152	52.987	76.777	107.810	147.562	197.718
3	3.451	7.387	13.859	23.558	37.345	56.240	81.423	114.243	156.252	209.217
4	3.671	7.842	14.694	24.952	39.521	59.473	86.041	120.644	164.904	220.671
5	3.889	8.295	15.526	26.343	41.694	62.702	90.658	127.043	173.559	232.135
6	4.107	8.748	16.358	27.734	43.869	65.934	95.280	133.455	182.229	243.623
7	4.325	9.202	17.193	29.132	46.053	69.181	99.925	139.899	190.948	255.175
8	4.544	9.658	18.031	30.534	48.246	72.441	104.590	146.372	199.708	266.784
9	4.764	10.116	18.874	31.945	50.453	75.724	109.288	152.891	208.531	278.480
10	4.985	10.577	19.723	33.365	52.675	79.030	114.019	159.458	217.419	290.264

Pb-Poly 100 keV Exposure Buildup Factors

Exposure	1	2	3	4	5	6	7	8	9	10
1	3.200	6.568	12.204	20.806	33.245	50.558	73.948	104.799	144.689	195.411
2	4.228	8.408	15.274	25.533	40.079	59.982	86.474	120.972	165.088	220.649
3	5.634	10.971	19.587	32.206	49.767	73.379	104.318	144.043	194.207	256.683
4	7.668	14.731	25.953	42.105	64.189	93.383	131.026	178.637	237.932	310.841
5	10.725	20.442	35.684	57.301	86.410	124.302	172.420	232.383	306.001	395.298
6	15.457	29.358	50.953	81.247	121.555	173.365	238.301	318.154	414.893	530.703
7	22.953	43.584	75.433	119.792	178.331	252.887	345.411	457.994	592.895	752.578
8	35.065	66.710	115.399	182.958	271.695	384.082	522.651	690.052	889.071	1122.680
9	54.967	104.907	181.670	288.067	427.564	603.782	820.327	1080.870	1389.180	1749.170
10	88.162	168.901	293.093	465.369	691.298	976.605	1326.870	1747.670	2244.590	2823.300

Pb-Poly 500 keV Exposure Buildup Factors

Exposure	1	2	3	4	5	6	7	8	9	10
1	2.372	3.707	5.381	7.426	9.863	12.708	15.972	19.666	23.797	28.370
2	2.761	4.259	6.134	8.415	11.122	14.267	17.862	21.914	26.428	31.409
3	3.123	4.782	6.854	9.368	12.341	15.786	19.710	24.119	29.019	34.413
4	3.474	5.293	7.562	10.308	13.547	17.292	21.547	26.317	31.605	37.417
5	3.820	5.801	8.268	11.247	14.756	18.802	23.392	28.527	34.212	40.442
6	4.166	6.312	8.978	12.193	15.972	20.325	25.254	30.760	36.844	43.503
7	4.514	6.825	9.694	13.147	17.202	21.865	27.137	33.019	39.509	46.604
8	4.867	7.345	10.419	14.115	18.449	23.427	29.049	35.313	42.216	49.758
9	5.223	7.873	11.154	15.097	19.715	25.014	30.991	37.645	44.968	52.962
10	5.585	8.408	11.901	16.094	21.002	26.626	32.966	40.016	47.771	56.221

Pb-Poly 1 MeV Exposure Buildup Factors

Exposure	1	2	3	4	5	6	7	8	9	10
1	2.344	3.431	4.636	5.954	7.376	8.896	10.508	12.205	13.983	15.835
2	2.880	4.110	5.460	6.918	8.476	10.126	11.863	13.680	15.574	17.538
3	3.385	4.763	6.261	7.863	9.561	11.345	13.211	15.153	17.167	19.247
4	3.875	5.404	7.052	8.802	10.642	12.564	14.563	16.633	18.771	20.970
5	4.360	6.042	7.842	9.741	11.726	13.788	15.923	18.124	20.388	22.709
6	4.843	6.680	8.634	10.684	12.817	15.022	17.295	19.629	22.022	24.468
7	5.329	7.322	9.432	11.636	13.917	16.268	18.681	21.151	23.675	26.247
8	5.818	7.969	10.237	12.597	15.030	17.528	20.084	22.692	25.349	28.049
9	6.311	8.622	11.051	13.568	16.155	18.802	21.502	24.249	27.042	29.871
10	6.809	9.283	11.874	14.551	17.295	20.094	22.940	25.829	28.758	31.720

Pb-Poly 2 MeV Exposure Buildup Factors

Exposure	1	2	3	4	5	6	7	8	9	10
1	2.176	2.972	3.777	4.594	5.423	6.262	7.110	7.964	8.821	9.680
2	2.706	3.564	4.414	5.264	6.119	6.979	7.844	8.712	9.581	10.449
3	3.227	4.156	5.055	5.942	6.825	7.707	8.590	9.471	10.351	11.229
4	3.749	4.753	5.705	6.630	7.542	8.446	9.346	10.241	11.132	12.018
5	4.277	5.358	6.364	7.328	8.269	9.196	10.113	11.022	11.923	12.816
6	4.812	5.972	7.033	8.038	9.008	9.957	10.891	11.813	12.724	13.624
7	5.354	6.596	7.713	8.758	9.758	10.729	11.679	12.613	13.533	14.440
8	5.906	7.230	8.404	9.490	10.519	11.512	12.479	13.425	14.353	15.266
9	6.466	7.873	9.106	10.231	11.291	12.305	13.288	14.245	15.182	16.100
10	7.034	8.527	9.817	10.984	12.072	13.108	14.106	15.074	16.018	16.941

Pb-Poly 6 MeV Exposure Buildup Factors

Exposure	1	2	3	4	5	6	7	8	9	10
1	1.663	2.102	2.520	2.921	3.307	3.678	4.036	4.381	4.713	5.033
2	1.923	2.330	2.726	3.112	3.486	3.847	4.196	4.533	4.857	5.170
3	2.200	2.572	2.945	3.313	3.673	4.022	4.361	4.689	5.005	5.310
4	2.499	2.833	3.178	3.525	3.869	4.205	4.532	4.849	5.157	5.453
5	2.823	3.113	3.425	3.749	4.074	4.395	4.709	5.015	5.312	5.599
6	3.176	3.415	3.690	3.986	4.289	4.593	4.893	5.186	5.472	5.749
7	3.561	3.742	3.973	4.237	4.516	4.800	5.083	5.362	5.636	5.902
8	3.981	4.095	4.276	4.503	4.754	5.015	5.280	5.544	5.804	6.059
9	4.441	4.477	4.600	4.785	5.004	5.241	5.486	5.733	5.979	6.221
10	4.943	4.891	4.948	5.085	5.269	5.478	5.700	5.929	6.158	6.387

Pb-Poly 10 MeV Exposure Buildup Factors

Exposure	1	2	3	4	5	6	7	8	9	10
1	1.497	1.814	2.119	2.409	2.684	2.945	3.195	3.433	3.659	3.876
2	1.695	1.957	2.235	2.508	2.772	3.026	3.268	3.500	3.721	3.933
3	1.918	2.116	2.362	2.616	2.867	3.111	3.345	3.570	3.785	3.992
4	2.174	2.295	2.502	2.734	2.969	3.201	3.426	3.644	3.853	4.053
5	2.469	2.499	2.659	2.863	3.080	3.298	3.512	3.721	3.923	4.117
6	2.812	2.731	2.834	3.004	3.199	3.402	3.604	3.803	3.996	4.183
7	3.213	2.997	3.030	3.160	3.329	3.513	3.702	3.890	4.074	4.253
8	3.683	3.304	3.252	3.333	3.471	3.634	3.807	3.982	4.156	4.327
9	4.237	3.658	3.503	3.526	3.627	3.765	3.919	4.080	4.243	4.404
10	4.890	4.069	3.789	3.742	3.800	3.907	4.040	4.185	4.335	4.486

Stainless Steel Followed by Lead

SS- Pb 65 keV Exposure Buildup Factors

Exposure	1	2	3	4	5	6	7	8	9	10
1	1.497	1.595	1.696	1.797	1.899	2.002	2.105	2.207	2.310	2.414
2	1.637	1.726	1.823	1.922	2.023	2.125	2.228	2.330	2.433	2.538
3	1.773	1.856	1.950	2.048	2.148	2.250	2.352	2.454	2.558	2.664
4	1.906	1.986	2.078	2.174	2.274	2.375	2.478	2.581	2.686	2.792
5	2.039	2.116	2.206	2.302	2.402	2.503	2.605	2.709	2.815	2.923
6	2.173	2.248	2.336	2.432	2.530	2.631	2.734	2.839	2.946	3.055
7	2.308	2.380	2.468	2.562	2.661	2.762	2.865	2.971	3.079	3.190
8	2.445	2.515	2.601	2.696	2.794	2.895	2.999	3.106	3.217	3.328
9	2.583	2.651	2.736	2.830	2.928	3.030	3.136	3.244	3.355	3.468
10	2.723	2.789	2.874	2.967	3.066	3.168	3.275	3.384	3.496	3.611

SS- Pb 100 keV Exposure Buildup Factors

Exposure	1	2	3	4	5	6	7	8	9	10
1	2.578	3.354	4.360	5.770	7.846	11.010	15.967	23.914	36.900	58.475
2	3.037	3.906	5.053	6.687	9.119	12.860	18.769	28.309	43.994	70.201
3	3.481	4.448	5.738	7.596	10.380	14.690	21.536	32.643	50.989	81.772
4	3.929	4.999	6.436	8.520	11.659	16.544	24.335	37.016	58.032	93.402
5	4.387	5.564	7.154	9.469	12.972	18.443	27.193	41.481	65.221	105.263
6	4.859	6.150	7.897	10.452	14.331	20.407	30.150	46.091	72.627	117.463
7	5.350	6.758	8.668	11.472	15.740	22.441	33.208	50.856	80.275	130.045
8	5.860	7.390	9.471	12.532	17.204	24.552	36.381	55.795	88.203	143.093
9	6.393	8.050	10.309	13.638	18.730	26.752	39.686	60.939	96.453	156.667
10	6.948	8.739	11.183	14.792	20.322	29.048	43.132	66.302	105.052	170.804

SS- Pb 500 keV Exposure Buildup Factors

Exposure	1	2	3	4	5	6	7	8	9	10
1	1.662	1.820	1.995	2.176	2.361	2.550	2.742	2.939	3.139	3.343
2	2.077	2.148	2.278	2.430	2.596	2.770	2.951	3.138	3.331	3.528
3	2.510	2.489	2.571	2.694	2.839	2.998	3.166	3.344	3.527	3.718
4	2.967	2.845	2.877	2.968	3.090	3.232	3.388	3.554	3.729	3.912
5	3.450	3.218	3.194	3.251	3.349	3.473	3.615	3.770	3.936	4.110
6	3.959	3.608	3.525	3.544	3.617	3.722	3.849	3.992	4.147	4.313
7	4.495	4.016	3.868	3.848	3.893	3.978	4.089	4.219	4.364	4.521
8	5.061	4.442	4.226	4.163	4.179	4.242	4.336	4.453	4.586	4.733
9	5.656	4.887	4.597	4.489	4.473	4.514	4.590	4.693	4.814	4.951
10	6.281	5.351	4.982	4.826	4.778	4.793	4.852	4.939	5.048	5.174

SS- Pb 1 MeV Exposure Buildup Factors

Exposure	1	2	3	4	5	6	7	8	9	10
1	1.843	2.150	2.459	2.766	3.074	3.384	3.697	4.013	4.333	4.656
2	2.329	2.568	2.840	3.125	3.418	3.716	4.020	4.329	4.643	4.962
3	2.829	2.996	3.231	3.491	3.767	4.054	4.349	4.650	4.958	5.271
4	3.347	3.437	3.630	3.866	4.124	4.397	4.681	4.974	5.275	5.583
5	3.882	3.889	4.040	4.247	4.486	4.745	5.018	5.302	5.596	5.897
6	4.436	4.354	4.458	4.636	4.854	5.097	5.359	5.633	5.919	6.213
7	5.008	4.831	4.886	5.032	5.228	5.455	5.703	5.968	6.244	6.531
8	5.598	5.320	5.323	5.436	5.608	5.818	6.052	6.305	6.573	6.852
9	6.205	5.821	5.768	5.846	5.993	6.184	6.404	6.645	6.903	7.174
10	6.829	6.333	6.221	6.262	6.384	6.555	6.759	6.988	7.235	7.498

SS- Pb 2 MeV Exposure Buildup Factors

Exposure	1	2	3	4	5	6	7	8	9	10
1	1.925	2.322	2.720	3.122	3.530	3.944	4.364	4.791	5.224	5.664
2	2.453	2.821	3.209	3.608	4.015	4.431	4.853	5.283	5.719	6.162
3	2.988	3.329	3.707	4.101	4.508	4.924	5.348	5.780	6.218	6.664
4	3.533	3.846	4.212	4.602	5.006	5.422	5.847	6.280	6.720	7.167
5	4.088	4.371	4.724	5.108	5.510	5.924	6.349	6.783	7.224	7.673
6	4.654	4.905	5.243	5.620	6.018	6.430	6.855	7.289	7.730	8.179
7	5.229	5.445	5.768	6.136	6.529	6.939	7.362	7.796	8.237	8.686
8	5.812	5.991	6.297	6.656	7.044	7.451	7.871	8.303	8.744	9.192
9	6.402	6.543	6.830	7.179	7.560	7.963	8.381	8.811	9.250	9.698
10	6.998	7.099	7.367	7.704	8.078	8.476	8.891	9.319	9.756	10.202

SS- Pb 6 MeV Exposure Buildup Factors

Exposure	1	2	3	4	5	6	7	8	9	10
1	1.756	2.084	2.437	2.821	3.240	3.700	4.205	4.760	5.369	6.038
2	2.199	2.567	2.969	3.408	3.890	4.419	5.000	5.638	6.338	7.107
3	2.650	3.063	3.519	4.018	4.566	5.168	5.828	6.553	7.349	8.223
4	3.113	3.575	4.087	4.649	5.266	5.944	6.687	7.503	8.399	9.382
5	3.589	4.103	4.673	5.301	5.990	6.746	7.576	8.487	9.486	10.582
6	4.079	4.646	5.277	5.972	6.736	7.573	8.492	9.500	10.606	11.818
7	4.581	5.203	5.897	6.662	7.502	8.423	9.434	10.541	11.757	13.089
8	5.095	5.773	6.532	7.368	8.286	9.293	10.398	11.608	12.936	14.390
9	5.620	6.356	7.180	8.089	9.088	10.183	11.383	12.699	14.141	15.720
10	6.156	6.951	7.842	8.825	9.905	11.090	12.389	13.811	15.370	17.077

SS- Pb 10 MeV Exposure Buildup Factors

Exposure	1	2	3	4	5	6	7	8	9	10
1	1.765	2.141	2.561	3.045	3.609	4.272	5.057	5.989	7.098	8.423
2	2.154	2.597	3.101	3.688	4.377	5.191	6.158	7.310	8.685	10.333
3	2.553	3.071	3.668	4.367	5.191	6.169	7.334	8.725	10.390	12.388
4	2.968	3.569	4.266	5.085	6.055	7.210	8.588	10.237	12.215	14.591
5	3.403	4.092	4.896	5.844	6.971	8.314	9.921	11.848	14.161	16.944
6	3.860	4.642	5.560	6.647	7.940	9.485	11.337	13.559	16.232	19.452
7	4.338	5.220	6.259	7.492	8.963	10.723	12.835	15.374	18.431	22.116
8	4.841	5.828	6.995	8.383	10.042	12.030	14.419	17.294	20.759	24.939
9	5.367	6.465	7.767	9.319	11.177	13.407	16.089	19.320	23.216	27.921
10	5.917	7.132	8.576	10.301	12.370	14.854	17.846	21.453	25.806	31.066

Lead Followed by Stainless Steel (Pb-SS)

Pb-SS 65 keV Exposure Buildup Factors

Exposure	1	2	3	4	5	6	7	8	9	10
1	1.346	1.485	1.614	1.739	1.864	1.989	2.114	2.241	2.368	2.498
2	1.447	1.585	1.715	1.842	1.968	2.094	2.221	2.349	2.479	2.610
3	1.544	1.684	1.815	1.944	2.071	2.199	2.328	2.458	2.590	2.723
4	1.640	1.783	1.916	2.046	2.176	2.305	2.436	2.568	2.701	2.837
5	1.736	1.881	2.017	2.149	2.280	2.412	2.545	2.678	2.814	2.951
6	1.832	1.980	2.118	2.252	2.386	2.519	2.654	2.790	2.927	3.067
7	1.928	2.079	2.219	2.356	2.492	2.627	2.764	2.902	3.042	3.184
8	2.025	2.179	2.321	2.460	2.598	2.736	2.875	3.016	3.158	3.302
9	2.122	2.279	2.424	2.566	2.706	2.846	2.987	3.130	3.275	3.421
10	2.219	2.380	2.528	2.672	2.814	2.957	3.101	3.246	3.393	3.542

Pb-SS 100 keV Exposure Buildup Factors

Exposure	1	2	3	4	5	6	7	8	9	10
1	1.490	1.728	1.988	2.257	2.533	2.818	3.113	3.420	3.740	4.074
2	1.683	1.830	2.060	2.317	2.589	2.873	3.169	3.477	3.799	4.135
3	1.958	1.969	2.151	2.388	2.651	2.931	3.225	3.534	3.857	4.195
4	2.370	2.175	2.277	2.479	2.724	2.995	3.286	3.593	3.916	4.254
5	3.014	2.499	2.469	2.607	2.821	3.074	3.355	3.657	3.977	4.316
6	4.051	3.029	2.778	2.807	2.962	3.182	3.443	3.733	4.046	4.381
7	5.758	3.924	3.300	3.139	3.186	3.343	3.566	3.832	4.131	4.457
8	8.622	5.466	4.209	3.712	3.567	3.607	3.757	3.977	4.246	4.553
9	13.497	8.164	5.821	4.730	4.237	4.063	4.076	4.208	4.419	4.688
10	21.900	12.940	8.718	6.570	5.445	4.877	4.636	4.602	4.703	4.898

Pb-SS 500 keV Exposure Buildup Factors

Exposure	1	2	3	4	5	6	7	8	9	10
1	2.192	3.110	4.088	5.146	6.290	7.525	8.853	10.278	11.799	13.421
2	2.546	3.552	4.618	5.767	7.005	8.337	9.765	11.293	12.921	14.652
3	2.876	3.974	5.133	6.375	7.710	9.141	10.672	12.306	14.043	15.886
4	3.197	4.388	5.641	6.980	8.414	9.947	11.583	13.324	15.173	17.132
5	3.514	4.802	6.151	7.588	9.122	10.759	12.502	14.354	16.318	18.394
6	3.831	5.217	6.664	8.201	9.837	11.581	13.433	15.398	17.479	19.674
7	4.151	5.636	7.182	8.820	10.562	12.413	14.378	16.457	18.656	20.976
8	4.473	6.060	7.708	9.450	11.297	13.259	15.337	17.535	19.855	22.299
9	4.800	6.491	8.241	10.088	12.045	14.118	16.313	18.630	21.074	23.646
10	5.132	6.928	8.783	10.738	12.805	14.993	17.305	19.745	22.315	25.017

Pb-SS 1 MeV Exposure Buildup Factors

Exposure	1	2	3	4	5	6	7	8	9	10
1	2.250	3.134	4.059	5.036	6.067	7.151	8.286	9.470	10.702	11.980
2	2.757	3.731	4.741	5.798	6.905	8.063	9.269	10.523	11.823	13.166
3	3.234	4.308	5.407	6.549	7.738	8.972	10.254	11.581	12.950	14.362
4	3.699	4.875	6.068	7.298	8.570	9.885	11.243	12.645	14.087	15.569
5	4.159	5.440	6.729	8.048	9.406	10.803	12.241	13.719	15.235	16.789
6	4.618	6.006	7.392	8.803	10.248	11.730	13.249	14.805	16.396	18.024
7	5.079	6.576	8.061	9.565	11.100	12.666	14.267	15.903	17.572	19.274
8	5.543	7.150	8.736	10.336	11.960	13.614	15.299	17.016	18.763	20.542
9	6.011	7.730	9.418	11.114	12.831	14.573	16.344	18.143	19.970	21.825
10	6.484	8.316	10.109	11.903	13.713	15.545	17.402	19.285	21.192	23.126

Pb-SS 2 MeV Exposure Buildup Factors

Exposure	1	2	3	4	5	6	7	8	9	10
1	2.135	2.858	3.594	4.348	5.121	5.913	6.721	7.545	8.380	9.228
2	2.651	3.422	4.196	4.982	5.783	6.600	7.430	8.273	9.127	9.991
3	3.160	3.987	4.803	5.624	6.455	7.297	8.150	9.013	9.885	10.764
4	3.670	4.556	5.418	6.276	7.137	8.006	8.881	9.764	10.653	11.548
5	4.185	5.134	6.042	6.938	7.830	8.725	9.624	10.526	11.432	12.342
6	4.707	5.720	6.676	7.610	8.534	9.456	10.377	11.299	12.221	13.145
7	5.236	6.316	7.321	8.293	9.249	10.197	11.140	12.081	13.020	13.958
8	5.775	6.921	7.976	8.987	9.974	10.949	11.914	12.874	13.829	14.781
9	6.321	7.535	8.640	9.691	10.710	11.710	12.697	13.676	14.646	15.611
10	6.876	8.159	9.315	10.405	11.455	12.482	13.491	14.487	15.473	16.451

Pb-SS 6 MeV Exposure Buildup Factors

Exposure	1	2	3	4	5	6	7	8	9	10
1	1.703	2.138	2.580	3.034	3.502	3.983	4.477	4.982	5.499	6.027
2	2.010	2.443	2.886	3.343	3.815	4.300	4.799	5.309	5.830	6.361
3	2.337	2.772	3.216	3.675	4.150	4.639	5.141	5.654	6.179	6.713
4	2.692	3.128	3.573	4.034	4.510	5.001	5.505	6.021	6.548	7.084
5	3.079	3.517	3.961	4.421	4.897	5.389	5.894	6.411	6.938	7.476
6	3.502	3.940	4.381	4.839	5.314	5.804	6.308	6.825	7.352	7.889
7	3.966	4.402	4.839	5.291	5.762	6.249	6.751	7.265	7.791	8.326
8	4.474	4.907	5.336	5.781	6.245	6.726	7.224	7.734	8.256	8.788
9	5.031	5.459	5.877	6.311	6.766	7.239	7.730	8.234	8.750	9.277
10	5.643	6.062	6.465	6.886	7.328	7.790	8.271	8.767	9.276	9.796

Pb-SS 10 MeV Exposure Buildup Factors

Exposure	1	2	3	4	5	6	7	8	9	10
1	1.632	1.966	2.313	2.677	3.060	3.463	3.886	4.331	4.797	5.284
2	1.937	2.252	2.590	2.952	3.336	3.743	4.172	4.623	5.096	5.591
3	2.281	2.580	2.909	3.267	3.652	4.061	4.494	4.951	5.431	5.934
4	2.676	2.960	3.279	3.631	4.013	4.424	4.860	5.322	5.808	6.318
5	3.138	3.404	3.708	4.051	4.430	4.839	5.277	5.743	6.234	6.750
6	3.679	3.924	4.210	4.540	4.911	5.317	5.754	6.221	6.716	7.237
7	4.318	4.536	4.798	5.111	5.470	5.868	6.302	6.769	7.265	7.790
8	5.074	5.259	5.490	5.778	6.120	6.507	6.933	7.396	7.892	8.417
9	5.971	6.115	6.305	6.562	6.879	7.248	7.663	8.118	8.609	9.133
10	7.041	7.132	7.270	7.483	7.767	8.112	8.509	8.951	9.434	9.953

Aluminum followed by Stainless Steel (Al-SS)

Al-SS 65 keV Exposure Buildup

Exposure	1	2	3	4	5	6	7	8	9	10
1	1.634	1.703	1.804	1.915	2.032	2.153	2.276	2.402	2.530	2.660
2	2.054	2.057	2.128	2.225	2.334	2.450	2.572	2.698	2.828	2.960
3	2.509	2.445	2.486	2.567	2.667	2.778	2.898	3.024	3.155	3.290
4	3.007	2.873	2.881	2.943	3.033	3.139	3.256	3.382	3.513	3.651
5	3.555	3.345	3.316	3.358	3.436	3.535	3.649	3.774	3.907	4.046
6	4.160	3.865	3.795	3.814	3.878	3.971	4.079	4.204	4.339	4.479
7	4.828	4.438	4.323	4.315	4.365	4.446	4.553	4.676	4.809	4.955
8	5.564	5.069	4.904	4.865	4.898	4.969	5.071	5.192	5.325	5.474
9	6.376	5.764	5.542	5.470	5.484	5.543	5.638	5.757	5.890	6.042
10	7.270	6.529	6.243	6.135	6.127	6.172	6.260	6.376	6.509	6.664

Al-SS 100 keV Exposure Buildup

Exposure	1	2	3	4	5	6	7	8	9	10
1	1.903	2.111	2.353	2.611	2.883	3.168	3.467	3.779	4.106	4.449
2	2.500	2.616	2.820	3.060	3.325	3.609	3.911	4.230	4.567	4.921
3	3.154	3.171	3.331	3.550	3.806	4.088	4.393	4.718	5.064	5.429
4	3.877	3.781	3.891	4.086	4.330	4.608	4.914	5.246	5.599	5.977
5	4.678	4.453	4.505	4.671	4.900	5.173	5.479	5.814	6.177	6.563
6	5.567	5.193	5.178	5.310	5.519	5.784	6.089	6.427	6.797	7.194
7	6.553	6.007	5.915	6.005	6.192	6.446	6.747	7.087	7.464	7.870
8	7.644	6.903	6.721	6.763	6.922	7.162	7.457	7.800	8.180	8.595
9	8.850	7.886	7.601	7.587	7.714	7.936	8.223	8.565	8.949	9.372
10	10.181	8.965	8.562	8.483	8.572	8.773	9.048	9.385	9.774	10.205

Al-SS 500 keV Exposure Buildup

Exposure	1	2	3	4	5	6	7	8	9	10
1	2.623	3.509	4.471	5.517	6.649	7.870	9.184	10.590	12.092	13.691
2	3.548	4.482	5.511	6.628	7.837	9.137	10.529	12.017	13.601	15.283
3	4.565	5.546	6.639	7.828	9.112	10.489	11.960	13.529	15.194	16.959
4	5.682	6.705	7.859	9.118	10.475	11.928	13.477	15.125	16.872	18.719
5	6.906	7.962	9.174	10.499	11.927	13.455	15.082	16.808	18.635	20.563
6	8.238	9.319	10.584	11.973	13.470	15.071	16.773	18.577	20.484	22.493
7	9.682	10.779	12.092	13.540	15.105	16.777	18.553	20.434	22.419	24.509
8	11.241	12.342	13.697	15.202	16.831	18.573	20.422	22.378	24.441	26.611
9	12.914	14.010	15.401	16.960	18.650	20.459	22.379	24.410	26.550	28.799
10	14.703	15.784	17.206	18.813	20.563	22.437	24.427	26.532	28.748	31.075

Al-SS 1 MeV Exposure Buildup

Exposure	1	2	3	4	5	6	7	8	9	10
1	2.488	3.339	4.242	5.200	6.212	7.277	8.392	9.556	10.767	12.023
2	3.349	4.242	5.194	6.201	7.262	8.372	9.532	10.739	11.990	13.285
3	4.266	5.200	6.199	7.253	8.358	9.513	10.715	11.962	13.251	14.582
4	5.242	6.213	7.255	8.352	9.500	10.696	11.937	13.222	14.547	15.912
5	6.274	7.279	8.359	9.497	10.684	11.918	13.197	14.517	15.876	17.273
6	7.360	8.393	9.510	10.685	11.909	13.179	14.492	15.845	17.236	18.663
7	8.498	9.555	10.704	11.913	13.172	14.475	15.820	17.205	18.625	20.081
8	9.686	10.762	11.940	13.181	14.471	15.805	17.180	18.593	20.041	21.523
9	10.920	12.011	13.215	14.484	15.803	17.166	18.569	20.009	21.482	22.989
10	12.198	13.300	14.527	15.822	17.168	18.557	19.986	21.451	22.948	24.477

Al-SS 2 MeV Exposure Buildup

Exposure	1	2	3	4	5	6	7	8	9	10
1	2.286	2.996	3.724	4.473	5.241	6.028	6.831	7.649	8.480	9.322
2	2.997	3.725	4.473	5.242	6.028	6.831	7.649	8.479	9.320	10.171
3	3.722	4.469	5.237	6.023	6.826	7.643	8.473	9.315	10.165	11.023
4	4.463	5.227	6.013	6.815	7.632	8.462	9.303	10.154	11.012	11.876
5	5.217	5.997	6.799	7.616	8.446	9.287	10.137	10.995	11.859	12.728
6	5.984	6.778	7.594	8.423	9.264	10.114	10.973	11.837	12.706	13.579
7	6.760	7.566	8.394	9.235	10.086	10.944	11.809	12.678	13.551	14.426
8	7.545	8.361	9.200	10.050	10.909	11.774	12.644	13.517	14.392	15.269
9	8.336	9.161	10.009	10.867	11.732	12.603	13.477	14.351	15.228	16.105
10	9.132	9.963	10.819	11.684	12.553	13.427	14.304	15.182	16.060	16.937

Al-SS 6 MeV Exposure Buildup

Exposure	1	2	3	4	5	6	7	8	9	10
1	1.902	2.356	2.814	3.282	3.761	4.253	4.757	5.272	5.798	6.333
2	2.377	2.848	3.325	3.811	4.309	4.817	5.337	5.866	6.405	6.952
3	2.839	3.333	3.830	4.336	4.851	5.376	5.911	6.454	7.005	7.564
4	3.294	3.812	4.331	4.855	5.388	5.929	6.478	7.035	7.598	8.167
5	3.743	4.286	4.825	5.369	5.919	6.475	7.038	7.608	8.181	8.761
6	4.187	4.754	5.314	5.876	6.443	7.013	7.590	8.172	8.756	9.346
7	4.625	5.216	5.796	6.376	6.959	7.543	8.133	8.726	9.321	9.920
8	5.058	5.671	6.272	6.869	7.466	8.065	8.667	9.270	9.876	10.482
9	5.484	6.119	6.739	7.354	7.965	8.578	9.191	9.804	10.420	11.035
10	5.904	6.560	7.199	7.829	8.455	9.080	9.705	10.328	10.953	11.576

Al-SS 10 MeV Exposure Buildup

Exposure	1	2	3	4	5	6	7	8	9	10
1	1.758	2.132	2.510	2.900	3.307	3.733	4.178	4.644	5.130	5.638
2	2.138	2.537	2.942	3.360	3.796	4.250	4.725	5.220	5.736	6.274
3	2.504	2.933	3.367	3.815	4.280	4.764	5.268	5.793	6.338	6.906
4	2.863	3.324	3.788	4.266	4.761	5.274	5.807	6.361	6.936	7.533
5	3.216	3.710	4.206	4.713	5.237	5.780	6.341	6.924	7.529	8.154
6	3.566	4.092	4.619	5.156	5.709	6.280	6.870	7.483	8.115	8.768
7	3.912	4.471	5.028	5.595	6.176	6.775	7.394	8.034	8.694	9.376
8	4.254	4.845	5.432	6.028	6.638	7.265	7.911	8.579	9.267	9.976
9	4.592	5.215	5.832	6.456	7.094	7.748	8.422	9.117	9.832	10.568
10	4.926	5.580	6.226	6.878	7.544	8.226	8.926	9.649	10.390	11.152

Stainless Steel followed by Aluminum (SS-Al)

SS-Al 65 keV Exposure Buildup

Exposure	1	2	3	4	5	6	7	8	9	10
1	1.975	2.682	3.414	4.201	5.061	6.006	7.048	8.197	9.465	10.863
2	2.168	2.918	3.692	4.523	5.429	6.424	7.520	8.726	10.057	11.523
3	2.353	3.148	3.966	4.843	5.797	6.843	7.993	9.259	10.653	12.189
4	2.535	3.376	4.240	5.163	6.166	7.264	8.469	9.795	11.255	12.861
5	2.715	3.605	4.515	5.485	6.538	7.689	8.951	10.338	11.864	13.543
6	2.897	3.835	4.792	5.811	6.914	8.119	9.439	10.888	12.482	14.234
7	3.080	4.068	5.073	6.140	7.295	8.554	9.934	11.447	13.109	14.936
8	3.265	4.303	5.356	6.474	7.681	8.997	10.436	12.014	13.747	15.650
9	3.451	4.541	5.644	6.812	8.073	9.445	10.945	12.589	14.394	16.374
10	3.641	4.782	5.936	7.156	8.471	9.901	11.464	13.176	15.053	17.113

SS-Al 100 keV Exposure Buildup

Exposure	1	2	3	4	5	6	7	8	9	10
1	2.410	3.573	4.836	6.239	7.808	9.565	11.530	13.725	16.170	18.890
2	2.855	4.138	5.527	7.065	8.780	10.697	12.836	15.221	17.873	20.818
3	3.285	4.700	6.223	7.904	9.773	11.857	14.180	16.764	19.633	22.814
4	3.718	5.271	6.936	8.768	10.801	13.061	15.576	18.369	21.467	24.896
5	4.160	5.858	7.673	9.663	11.866	14.311	17.027	20.039	23.375	27.065
6	4.616	6.467	8.437	10.593	12.975	15.614	18.541	21.783	25.369	29.332
7	5.089	7.100	9.234	11.563	14.132	16.975	20.122	23.605	27.454	31.702
8	5.580	7.759	10.065	12.577	15.342	18.398	21.777	25.513	29.637	34.183
9	6.092	8.446	10.932	13.636	16.607	19.886	23.508	27.507	31.918	36.779
10	6.627	9.164	11.839	14.743	17.929	21.441	25.317	29.594	34.306	39.495

SS-AI 500 keV Exposure Buildup

Exposure	1	2	3	4	5	6	7	8	9	10
1	2.829	3.978	5.262	6.694	8.284	10.036	11.954	14.043	16.303	18.738
2	3.864	5.193	6.656	8.271	10.045	11.985	14.095	16.377	18.835	21.471
3	4.992	6.524	8.184	9.993	11.963	14.100	16.409	18.893	21.555	24.397
4	6.224	7.977	9.848	11.864	14.040	16.383	18.899	21.592	24.464	27.519
5	7.563	9.556	11.653	13.887	16.278	18.835	21.567	24.476	27.566	30.840
6	9.013	11.264	13.599	16.063	18.679	21.461	24.416	27.549	30.863	34.363
7	10.578	13.102	15.689	18.394	21.246	24.260	27.446	30.811	34.356	38.088
8	12.258	15.074	17.926	20.884	23.982	27.238	30.664	34.267	38.052	42.022
9	14.057	17.180	20.312	23.534	26.889	30.396	34.070	37.920	41.950	46.167
10	15.976	19.424	22.849	26.348	29.969	33.736	37.667	41.771	46.055	50.524

SS-AI 1 MeV Exposure Buildup

Exposure	1	2	3	4	5	6	7	8	9	10
1	2.583	3.539	4.563	5.658	6.822	8.054	9.349	10.704	12.115	13.581
2	3.506	4.551	5.658	6.830	8.068	9.368	10.728	12.145	13.616	15.137
3	4.489	5.631	6.821	8.070	9.379	10.746	12.170	13.647	15.174	16.748
4	5.536	6.777	8.051	9.376	10.754	12.186	13.670	15.205	16.786	18.412
5	6.644	7.987	9.345	10.744	12.189	13.684	15.228	16.817	18.450	20.125
6	7.813	9.259	10.700	12.170	13.682	15.238	16.838	18.480	20.163	21.885
7	9.040	10.589	12.113	13.655	15.231	16.846	18.500	20.194	21.925	23.691
8	10.323	11.977	13.582	15.194	16.832	18.504	20.212	21.954	23.731	25.541
9	11.659	13.417	15.104	16.785	18.484	20.211	21.969	23.759	25.580	27.430
10	13.046	14.910	16.677	18.426	20.184	21.965	23.772	25.608	27.470	29.360

SS-AI 2 MeV Exposure Buildup

Exposure	1	2	3	4	5	6	7	8	9	10
1	2.317	3.054	3.807	4.577	5.362	6.161	6.972	7.791	8.617	9.448
2	3.048	3.805	4.576	5.362	6.161	6.972	7.791	8.618	9.450	10.285
3	3.799	4.578	5.366	6.166	6.977	7.797	8.624	9.456	10.292	11.129
4	4.573	5.373	6.176	6.987	7.808	8.635	9.467	10.303	11.141	11.979
5	5.368	6.188	7.003	7.824	8.651	9.484	10.319	11.157	11.995	12.832
6	6.183	7.020	7.846	8.674	9.507	10.342	11.180	12.018	12.855	13.689
7	7.016	7.868	8.703	9.536	10.372	11.209	12.046	12.883	13.718	14.548
8	7.864	8.730	9.571	10.408	11.245	12.082	12.918	13.752	14.582	15.408
9	8.725	9.604	10.449	11.287	12.124	12.959	13.792	14.622	15.447	16.268
10	9.599	10.488	11.336	12.174	13.009	13.841	14.670	15.494	16.313	17.127

SS-Al 6 MeV Exposure Buildup

Exposure	1	2	3	4	5	6	7	8	9	10
1	1.820	2.255	2.683	3.104	3.521	3.932	4.339	4.740	5.135	5.524
2	2.231	2.646	3.061	3.474	3.884	4.289	4.689	5.083	5.471	5.853
3	2.647	3.045	3.448	3.852	4.253	4.650	5.042	5.429	5.809	6.184
4	3.074	3.453	3.843	4.236	4.627	5.015	5.399	5.777	6.149	6.515
5	3.512	3.871	4.246	4.626	5.006	5.384	5.758	6.127	6.490	6.847
6	3.960	4.298	4.657	5.023	5.390	5.757	6.120	6.478	6.832	7.179
7	4.419	4.734	5.074	5.425	5.778	6.132	6.484	6.831	7.174	7.512
8	4.889	5.178	5.498	5.831	6.170	6.510	6.849	7.185	7.516	7.843
9	5.367	5.629	5.927	6.242	6.564	6.890	7.216	7.539	7.859	8.175
10	5.855	6.086	6.361	6.656	6.962	7.272	7.584	7.894	8.202	8.506

SS-Al 10 MeV Exposure Buildup

Exposure	1	2	3	4	5	6	7	8	9	10
1	1.629	1.953	2.271	2.584	2.895	3.202	3.506	3.807	4.104	4.398
2	1.935	2.234	2.538	2.843	3.146	3.447	3.746	4.042	4.335	4.624
3	2.249	2.525	2.815	3.110	3.405	3.700	3.993	4.284	4.571	4.854
4	2.575	2.828	3.103	3.387	3.674	3.961	4.247	4.530	4.811	5.089
5	2.916	3.144	3.403	3.674	3.950	4.228	4.506	4.783	5.057	5.328
6	3.271	3.474	3.714	3.971	4.236	4.504	4.773	5.041	5.307	5.571
7	3.643	3.817	4.038	4.279	4.530	4.787	5.046	5.305	5.563	5.819
8	4.032	4.175	4.373	4.597	4.834	5.078	5.326	5.575	5.824	6.071
9	4.438	4.547	4.721	4.925	5.146	5.377	5.612	5.850	6.089	6.328
10	4.861	4.933	5.080	5.264	5.467	5.683	5.905	6.132	6.360	6.589

Polyethylene Followed by Stainless Steel (Poly-SS)

Poly-SS 65 keV Exposure Buildup

Exposure	1	2	3	4	5	6	7	8	9	10
1	1.753	1.746	1.816	1.910	2.015	2.125	2.241	2.361	2.483	2.609
2	2.374	2.167	2.163	2.216	2.298	2.393	2.499	2.612	2.729	2.853
3	3.110	2.647	2.551	2.557	2.611	2.687	2.781	2.886	2.998	3.118
4	3.980	3.194	2.987	2.936	2.956	3.011	3.091	3.186	3.291	3.407
5	5.007	3.817	3.475	3.356	3.337	3.366	3.429	3.513	3.611	3.722
6	6.214	4.526	4.021	3.823	3.756	3.756	3.799	3.870	3.958	4.064
7	7.628	5.331	4.633	4.339	4.218	4.183	4.203	4.259	4.337	4.436
8	9.279	6.245	5.316	4.912	4.727	4.651	4.645	4.683	4.748	4.839
9	11.199	7.279	6.080	5.546	5.288	5.165	5.128	5.145	5.196	5.278
10	13.427	8.450	6.933	6.249	5.904	5.728	5.655	5.649	5.683	5.754

Poly-SS 100 keV Exposure Buildup

Exposure	1	2	3	4	5	6	7	8	9	10
1	1.924	2.097	2.320	2.565	2.825	3.099	3.387	3.689	4.006	4.339
2	2.565	2.586	2.746	2.955	3.194	3.455	3.735	4.033	4.349	4.682
3	3.287	3.123	3.206	3.374	3.588	3.833	4.103	4.397	4.709	5.041
4	4.106	3.712	3.705	3.824	4.008	4.235	4.492	4.777	5.087	5.418
5	5.038	4.362	4.246	4.307	4.456	4.660	4.903	5.178	5.483	5.811
6	6.098	5.079	4.833	4.827	4.934	5.111	5.337	5.602	5.897	6.221
7	7.302	5.869	5.471	5.385	5.443	5.590	5.794	6.045	6.331	6.649
8	8.668	6.740	6.163	5.984	5.987	6.097	6.277	6.509	6.786	7.097
9	10.212	7.700	6.914	6.629	6.567	6.635	6.786	7.001	7.263	7.565
10	11.955	8.756	7.729	7.320	7.184	7.205	7.324	7.514	7.762	8.054

Poly-SS 500 keV Exposure Buildup

Exposure	1	2	3	4	5	6	7	8	9	10
1	2.615	3.496	4.455	5.496	6.623	7.840	9.148	10.549	12.045	13.638
2	3.529	4.452	5.472	6.580	7.778	9.068	10.450	11.926	13.497	15.166
3	4.531	5.493	6.571	7.745	9.012	10.373	11.827	13.377	15.023	16.767
4	5.630	6.623	7.755	8.992	10.326	11.755	13.280	14.902	16.622	18.440
5	6.830	7.845	9.025	10.321	11.719	13.215	14.809	16.502	18.293	20.185
6	8.134	9.159	10.383	11.733	13.192	14.753	16.414	18.176	20.038	22.002
7	9.543	10.567	11.828	13.228	14.745	16.369	18.095	19.924	21.856	23.890
8	11.059	12.069	13.360	14.807	16.378	18.062	19.851	21.746	23.747	25.848
9	12.682	13.666	14.979	16.466	18.086	19.836	21.685	23.642	25.705	27.873
10	14.411	15.353	16.692	18.217	19.886	21.679	23.587	25.605	27.749	29.986

Poly-SS 1 MeV Exposure Buildup

Exposure	1	2	3	4	5	6	7	8	9	10
1	2.485	3.334	4.236	5.193	6.204	7.267	8.381	9.544	10.753	12.008
2	3.342	4.232	5.181	6.186	7.243	8.351	9.508	10.712	11.960	13.251
3	4.254	5.182	6.176	7.226	8.327	9.477	10.674	11.916	13.201	14.527
4	5.222	6.185	7.220	8.311	9.452	10.641	11.876	13.154	14.473	15.832
5	6.244	7.237	8.309	9.438	10.618	11.843	13.113	14.425	15.775	17.164
6	7.319	8.337	9.442	10.606	11.820	13.080	14.378	15.723	17.106	18.518
7	8.444	9.479	10.615	11.812	13.054	14.347	15.682	17.049	18.459	19.905
8	9.614	10.664	11.826	13.052	14.323	15.645	17.008	18.401	19.837	21.307
9	10.829	11.888	13.073	14.326	15.623	16.972	18.361	19.778	21.238	22.731
10	12.084	13.149	14.353	15.629	16.951	18.323	19.736	21.175	22.657	24.170

Poly-SS 2 MeV Exposure Buildup

Exposure	1	2	3	4	5	6	7	8	9	10
1	2.288	2.999	3.728	4.477	5.245	6.032	6.835	7.653	8.484	9.325
2	2.998	3.727	4.477	5.246	6.032	6.835	7.653	8.483	9.324	10.175
3	3.717	4.467	5.236	6.024	6.827	7.644	8.474	9.316	10.166	11.024
4	4.448	5.216	6.004	6.808	7.625	8.456	9.297	10.147	11.005	11.870
5	5.189	5.974	6.779	7.598	8.429	9.271	10.122	10.980	11.845	12.714
6	5.938	6.738	7.558	8.390	9.233	10.085	10.944	11.809	12.678	13.551
7	6.693	7.506	8.339	9.183	10.036	10.897	11.763	12.633	13.507	14.382
8	7.452	8.277	9.121	9.976	10.838	11.705	12.577	13.452	14.329	15.206
9	8.213	9.048	9.903	10.767	11.636	12.510	13.387	14.265	15.143	16.022
10	8.975	9.818	10.682	11.554	12.430	13.309	14.189	15.070	15.950	16.829

Poly-SS 6 MeV Exposure Buildup

Exposure	1	2	3	4	5	6	7	8	9	10
1	1.945	2.407	2.870	3.343	3.826	4.322	4.829	5.347	5.875	6.413
2	2.443	2.931	3.419	3.914	4.420	4.937	5.463	5.998	6.543	7.094
3	2.912	3.430	3.945	4.466	4.993	5.530	6.074	6.627	7.187	7.753
4	3.360	3.909	4.452	4.997	5.546	6.103	6.666	7.234	7.809	8.388
5	3.790	4.371	4.941	5.509	6.080	6.655	7.234	7.820	8.409	9.001
6	4.204	4.816	5.411	6.003	6.594	7.188	7.784	8.384	8.988	9.592
7	4.603	5.245	5.865	6.479	7.090	7.702	8.313	8.928	9.545	10.161
8	4.987	5.658	6.303	6.938	7.567	8.196	8.823	9.452	10.082	10.710
9	5.357	6.056	6.724	7.379	8.027	8.673	9.317	9.957	10.599	11.238
10	5.714	6.438	7.129	7.804	8.469	9.131	9.789	10.443	11.097	11.746

Poly-SS 10 MeV Exposure Buildup

Exposure	1	2	3	4	5	6	7	8	9	10
1	1.817	2.205	2.593	2.994	3.411	3.846	4.300	4.775	5.271	5.788
2	2.227	2.652	3.079	3.517	3.971	4.443	4.935	5.449	5.982	6.537
3	2.603	3.069	3.534	4.009	4.500	5.009	5.538	6.088	6.657	7.249
4	2.956	3.462	3.964	4.476	5.003	5.547	6.110	6.695	7.300	7.926
5	3.288	3.834	4.372	4.919	5.480	6.058	6.655	7.274	7.912	8.572
6	3.604	4.187	4.761	5.341	5.935	6.545	7.175	7.826	8.496	9.187
7	3.905	4.524	5.131	5.743	6.368	7.010	7.670	8.351	9.052	9.775
8	4.191	4.844	5.483	6.126	6.781	7.452	8.142	8.853	9.583	10.335
9	4.463	5.150	5.819	6.491	7.175	7.875	8.592	9.331	10.090	10.869
10	4.723	5.441	6.140	6.840	7.551	8.277	9.022	9.788	10.573	11.379

Stainless Steel Followed by Polyethylene (SS-Poly)

SS-Poly 65 keV Exposure Buildup

Exposure	1	2	3	4	5	6	7	8	9	10
1	3.119	6.676	12.524	21.290	33.760	50.862	73.672	103.426	141.542	189.638
2	3.434	7.310	13.666	23.172	36.666	55.137	79.732	111.763	152.737	204.375
3	3.731	7.915	14.765	24.993	39.488	59.302	85.651	119.927	163.725	218.865
4	4.022	8.512	15.850	26.793	42.284	63.436	91.534	128.051	174.672	233.316
5	4.311	9.106	16.934	28.594	45.083	67.577	97.434	136.204	185.664	247.838
6	4.601	9.702	18.022	30.404	47.898	71.746	103.375	144.418	196.744	262.479
7	4.892	10.303	19.120	32.230	50.741	75.956	109.377	152.720	207.946	277.288
8	5.187	10.911	20.230	34.078	53.617	80.217	115.454	161.127	219.293	292.290
9	5.485	11.524	21.352	35.946	56.526	84.529	121.604	169.637	230.780	307.480
10	5.786	12.147	22.491	37.843	59.481	88.908	127.853	178.284	242.457	322.925

SS-Poly 100 keV Exposure Buildup

Exposure	1	2	3	4	5	6	7	8	9	10
1	3.079	6.419	12.092	20.883	33.750	51.828	76.434	109.077	151.476	205.577
2	3.671	7.541	14.096	24.213	38.956	59.588	87.567	124.558	172.454	233.398
3	4.240	8.633	16.063	27.498	44.116	67.309	98.681	140.061	193.524	261.411
4	4.809	9.735	18.056	30.836	49.369	75.185	110.040	155.932	215.125	290.171
5	5.388	10.863	20.101	34.265	54.775	83.300	121.753	172.314	237.441	319.905
6	5.985	12.030	22.217	37.818	60.378	91.716	133.910	189.324	260.623	350.808
7	6.604	13.241	24.417	41.511	66.207	100.475	146.566	207.040	284.774	383.010
8	7.247	14.502	26.707	45.361	72.283	109.608	159.769	225.522	309.982	416.626
9	7.918	15.816	29.097	49.379	78.629	119.148	173.559	244.836	336.321	451.766
10	8.618	17.189	31.593	53.577	85.258	129.115	187.971	265.019	363.852	488.494

SS-Poly 500 keV Exposure Buildup

Exposure	1	2	3	4	5	6	7	8	9	10
1	2.914	4.372	6.199	8.402	10.990	13.974	17.366	21.173	25.404	30.065
2	4.007	5.808	8.046	10.698	13.759	17.232	21.122	25.435	30.179	35.359
3	5.200	7.390	10.086	13.232	16.810	20.811	25.235	30.087	35.373	41.101
4	6.506	9.127	12.324	16.011	20.147	24.715	29.710	35.133	40.990	47.291
5	7.928	11.022	14.766	19.037	23.775	28.950	34.552	40.580	47.038	53.938
6	9.471	13.079	17.415	22.315	27.698	33.520	39.766	46.432	53.524	61.046
7	11.137	15.299	20.272	25.848	31.919	38.430	45.356	52.693	60.447	68.622
8	12.929	17.687	23.344	29.641	36.445	43.684	51.329	59.372	67.818	76.675
9	14.848	20.245	26.632	33.697	41.278	49.289	57.690	66.473	75.642	85.216
10	16.897	22.975	30.138	38.020	46.424	55.247	64.443	74.001	83.925	94.238

SS-Poly 1 MeV Exposure Buildup

Exposure	1	2	3	4	5	6	7	8	9	10
1	2.632	3.725	4.933	6.244	7.655	9.159	10.752	12.428	14.184	16.012
2	3.590	4.845	6.201	7.643	9.169	10.777	12.466	14.231	16.070	17.976
3	4.615	6.046	7.558	9.133	10.774	12.485	14.267	16.118	18.037	20.018
4	5.707	7.326	9.000	10.710	12.466	14.278	16.151	18.085	20.081	22.134
5	6.866	8.682	10.523	12.370	14.240	16.152	18.112	20.127	22.197	24.318
6	8.090	10.111	12.123	14.108	16.093	18.102	20.149	22.242	24.383	26.570
7	9.375	11.609	13.798	15.923	18.021	20.126	22.258	24.426	26.636	28.887
8	10.720	13.175	15.543	17.809	20.022	22.221	24.434	26.675	28.951	31.262
9	12.122	14.803	17.355	19.764	22.089	24.383	26.676	28.987	31.327	33.696
10	13.578	16.493	19.232	21.785	24.223	26.608	28.980	31.360	33.761	36.185

SS-Poly 2 MeV Exposure Buildup

Exposure	1	2	3	4	5	6	7	8	9	10
1	2.340	3.122	3.915	4.723	5.544	6.376	7.217	8.064	8.915	9.767
2	3.086	3.905	4.720	5.543	6.376	7.217	8.064	8.915	9.768	10.621
3	3.855	4.712	5.548	6.384	7.226	8.073	8.924	9.778	10.631	11.483
4	4.648	5.543	6.398	7.244	8.092	8.943	9.796	10.649	11.501	12.350
5	5.462	6.396	7.267	8.120	8.972	9.824	10.677	11.528	12.377	13.221
6	6.297	7.267	8.153	9.012	9.865	10.716	11.566	12.414	13.257	14.095
7	7.151	8.156	9.054	9.915	10.768	11.616	12.462	13.304	14.141	14.972
8	8.021	9.060	9.967	10.830	11.679	12.523	13.363	14.198	15.027	15.849
9	8.905	9.976	10.892	11.753	12.598	13.436	14.268	15.094	15.913	16.725
10	9.802	10.903	11.826	12.684	13.522	14.352	15.175	15.991	16.800	17.601

SS-Poly 6 MeV Exposure Buildup

Exposure	1	2	3	4	5	6	7	8	9	10
1	1.797	2.230	2.643	3.040	3.422	3.789	4.143	4.485	4.813	5.130
2	2.182	2.577	2.966	3.345	3.711	4.065	4.407	4.737	5.055	5.361
3	2.571	2.930	3.295	3.654	4.004	4.343	4.672	4.989	5.295	5.591
4	2.969	3.291	3.629	3.967	4.299	4.623	4.937	5.241	5.535	5.819
5	3.377	3.659	3.968	4.283	4.596	4.903	5.202	5.493	5.775	6.047
6	3.795	4.034	4.312	4.602	4.895	5.184	5.468	5.744	6.013	6.273
7	4.222	4.416	4.660	4.925	5.196	5.466	5.733	5.995	6.250	6.498
8	4.658	4.804	5.013	5.250	5.498	5.749	5.999	6.245	6.486	6.721
9	5.102	5.197	5.369	5.577	5.801	6.031	6.264	6.494	6.721	6.943
10	5.554	5.596	5.728	5.905	6.104	6.314	6.528	6.742	6.954	7.163

SS-Poly 10 MeV Exposure Buildup

Exposure	1	2	3	4	5	6	7	8	9	10
1	1.579	1.900	2.204	2.491	2.763	3.022	3.268	3.503	3.727	3.941
2	1.842	2.120	2.400	2.670	2.929	3.176	3.413	3.639	3.855	4.062
3	2.110	2.347	2.601	2.853	3.098	3.333	3.560	3.776	3.984	4.183
4	2.389	2.582	2.809	3.041	3.270	3.492	3.708	3.914	4.113	4.304
5	2.679	2.825	3.022	3.233	3.445	3.654	3.857	4.054	4.243	4.425
6	2.982	3.077	3.242	3.430	3.624	3.818	4.008	4.194	4.374	4.547
7	3.297	3.338	3.469	3.631	3.806	3.984	4.161	4.335	4.505	4.669
8	3.626	3.608	3.702	3.837	3.991	4.153	4.316	4.478	4.637	4.792
9	3.969	3.888	3.941	4.048	4.180	4.324	4.472	4.622	4.770	4.915
10	4.325	4.177	4.187	4.264	4.372	4.497	4.630	4.767	4.903	5.039

Appendix 3: Number (Flux) Buildup Factors

The following tables present the exposure buildup factors calculated in PARTISN for various materials and energies. In each table, the first material thicknesses increase along the rows, the second material thicknesses increase along columns. For example, column 2 shows fractional differences for shields with 2 mfp of the first material followed by 1-10 mfp of the second material.

Aluminum followed by Lead (Al-Pb)

Al-Pb 65 keV Number (Flux) Buildup

Flux	1	2	3	4	5	6	7	8	9	10
1	1.477	1.501	1.561	1.634	1.713	1.794	1.878	1.963	2.049	2.137
2	1.853	1.810	1.839	1.895	1.963	2.039	2.118	2.201	2.287	2.374
3	2.261	2.149	2.146	2.183	2.240	2.308	2.383	2.463	2.547	2.634
4	2.707	2.523	2.484	2.500	2.544	2.604	2.674	2.750	2.832	2.919
5	3.199	2.935	2.857	2.850	2.879	2.929	2.993	3.065	3.145	3.230
6	3.741	3.390	3.267	3.235	3.247	3.287	3.343	3.411	3.489	3.572
7	4.342	3.894	3.724	3.664	3.659	3.672	3.722	3.786	3.861	3.944
8	5.001	4.446	4.222	4.129	4.104	4.101	4.142	4.200	4.271	4.353
9	5.729	5.055	4.769	4.640	4.591	4.572	4.602	4.653	4.721	4.800
10	6.531	5.724	5.371	5.201	5.127	5.087	5.106	5.150	5.213	5.290

Al-Pb 100 keV Number (Flux) Buildup

Flux	1	2	3	4	5	6	7	8	9	10
1	3.035	3.932	5.178	7.001	9.751	14.027	20.832	31.887	50.167	80.859
2	4.347	5.527	7.279	9.951	14.114	20.758	31.573	49.495	79.661	131.128
3	5.838	7.397	9.804	13.577	19.588	29.352	45.500	72.630	118.854	198.583
4	7.534	9.560	12.770	17.897	26.188	39.831	62.640	101.334	167.821	283.365
5	9.453	12.031	16.188	22.909	34.032	52.353	83.225	135.951	227.090	386.306
6	11.629	14.858	20.135	28.752	43.126	66.979	107.420	176.857	297.449	508.993
7	14.081	18.064	24.640	35.461	53.623	83.937	135.580	224.629	379.850	653.034
8	16.837	21.685	29.753	43.112	65.645	103.434	168.061	279.879	475.374	820.356
9	19.922	25.757	35.527	51.789	79.329	125.694	205.246	343.276	585.198	1013.040
10	23.368	30.320	42.025	61.586	94.827	150.975	247.574	415.580	710.665	1233.500

Al-Pb 500 keV Number (Flux) Buildup

Flux	1	2	3	4	5	6	7	8	9	10
1	1.819	1.978	2.167	2.364	2.567	2.775	2.987	3.204	3.425	3.650
2	2.322	2.352	2.477	2.636	2.813	3.000	3.196	3.400	3.609	3.825
3	2.851	2.740	2.799	2.916	3.064	3.231	3.409	3.599	3.797	4.002
4	3.413	3.146	3.131	3.205	3.322	3.466	3.627	3.802	3.987	4.182
5	4.009	3.569	3.476	3.502	3.587	3.707	3.850	4.009	4.181	4.364
6	4.641	4.011	3.832	3.808	3.858	3.953	4.076	4.220	4.378	4.550
7	5.309	4.472	4.201	4.122	4.137	4.205	4.308	4.434	4.579	4.738
8	6.015	4.952	4.582	4.446	4.422	4.462	4.543	4.653	4.783	4.930
9	6.759	5.452	4.976	4.779	4.715	4.725	4.783	4.875	4.990	5.124
10	7.542	5.971	5.384	5.122	5.015	4.995	5.030	5.102	5.202	5.322

Al-Pb 1 MeV Number (Flux) Buildup

Flux	1	2	3	4	5	6	7	8	9	10
1	2.149	2.523	2.904	3.285	3.667	4.051	4.439	4.831	5.227	5.628
2	2.798	3.061	3.386	3.733	4.091	4.458	4.833	5.214	5.602	5.996
3	3.471	3.613	3.880	4.190	4.523	4.872	5.232	5.602	5.980	6.365
4	4.173	4.183	4.385	4.656	4.962	5.291	5.635	5.993	6.360	6.737
5	4.903	4.770	4.903	5.131	5.408	5.715	6.043	6.387	6.743	7.110
6	5.662	5.373	5.431	5.614	5.860	6.144	6.454	6.783	7.127	7.484
7	6.449	5.992	5.971	6.105	6.318	6.577	6.869	7.182	7.514	7.859
8	7.262	6.627	6.522	6.605	6.782	7.015	7.287	7.584	7.901	8.235
9	8.101	7.277	7.082	7.111	7.251	7.457	7.706	7.987	8.290	8.612
10	8.963	7.941	7.652	7.624	7.725	7.903	8.130	8.392	8.680	8.989

Al-Pb 2 MeV Number (Flux) Buildup

Flux	1	2	3	4	5	6	7	8	9	10
1	2.466	3.031	3.603	4.183	4.771	5.370	5.978	6.597	7.227	7.867
2	3.257	3.769	4.322	4.895	5.482	6.082	6.694	7.318	7.952	8.597
3	4.061	4.517	5.050	5.615	6.200	6.801	7.415	8.042	8.680	9.329
4	4.881	5.276	5.787	6.342	6.923	7.524	8.139	8.768	9.408	10.060
5	5.714	6.046	6.531	7.075	7.651	8.249	8.865	9.495	10.137	10.790
6	6.561	6.824	7.281	7.812	8.382	8.977	9.591	10.221	10.864	11.518
7	7.418	7.609	8.037	8.552	9.114	9.705	10.317	10.946	11.588	12.242
8	8.284	8.399	8.795	9.294	9.846	10.432	11.041	11.668	12.309	12.963
9	9.157	9.193	9.555	10.036	10.578	11.157	11.762	12.386	13.025	13.678
10	10.034	9.988	10.315	10.777	11.308	11.879	12.479	13.102	13.735	14.388

Al-Pb 6 MeV Number (Flux) Buildup

Flux	1	2	3	4	5	6	7	8	9	10
1	3.043	3.788	4.581	5.448	6.401	7.452	8.614	9.900	11.321	12.893
2	4.010	4.869	5.798	6.818	7.941	9.181	10.551	12.064	13.737	15.584
3	4.956	5.936	7.007	8.184	9.482	10.913	12.494	14.239	16.165	18.292
4	5.889	6.995	8.209	9.546	11.020	12.644	14.437	16.415	18.597	21.003
5	6.813	8.045	9.404	10.901	12.551	14.369	16.374	18.585	21.022	23.709
6	7.728	9.087	10.590	12.247	14.072	16.083	18.300	20.745	23.429	26.396
7	8.634	10.119	11.766	13.583	15.578	17.781	20.210	22.885	25.821	29.065
8	9.532	11.141	12.926	14.899	17.072	19.466	22.094	24.997	28.193	31.712
9	10.417	12.149	14.073	16.201	18.546	21.127	23.970	27.088	30.532	34.321
10	11.290	13.142	15.204	17.485	19.998	22.764	25.810	29.150	32.837	36.894

Al-Pb 10 MeV Number (Flux) Buildup

Flux	1	2	3	4	5	6	7	8	9	10
1	3.962	5.247	6.643	8.246	10.125	12.511	15.213	18.446	22.327	26.996
2	5.044	6.581	8.282	10.257	12.586	15.358	18.919	22.970	27.845	33.724
3	6.080	7.876	9.888	12.237	15.020	18.343	22.331	27.129	33.360	40.463
4	7.093	9.150	11.474	14.199	17.438	21.315	25.977	31.596	38.384	46.598
5	8.092	10.412	13.047	16.147	19.843	24.275	29.612	36.055	43.847	53.286
6	9.082	11.659	14.610	18.085	22.233	27.216	33.238	40.502	49.295	59.952
7	10.061	12.899	16.159	20.007	24.609	30.144	36.841	44.926	54.721	66.602
8	11.032	14.127	17.695	21.915	26.968	33.052	40.421	49.324	60.117	73.216
9	11.993	15.343	19.216	23.805	29.306	35.936	43.971	53.687	65.473	79.784
10	12.944	16.547	20.723	25.677	31.623	38.794	47.492	58.014	70.786	86.300

Lead followed by Aluminum (Pb-Al)

Pb-Al 65 keV Number (Flux) Buildup

Flux	1	2	3	4	5	6	7	8	9	10
1	1.892	2.580	3.291	4.056	4.890	5.807	6.817	7.931	9.160	10.515
2	2.037	2.762	3.509	4.310	5.184	6.142	7.198	8.360	9.642	11.054
3	2.176	2.939	3.723	4.562	5.476	6.477	7.578	8.789	10.124	11.594
4	2.314	3.116	3.937	4.814	5.768	6.812	7.959	9.220	10.608	12.136
5	2.451	3.292	4.151	5.067	6.061	7.148	8.341	9.652	11.095	12.682
6	2.588	3.468	4.365	5.320	6.355	7.485	8.725	10.086	11.583	13.230
7	2.726	3.645	4.580	5.574	6.651	7.825	9.112	10.524	12.077	13.783
8	2.863	3.822	4.796	5.830	6.948	8.167	9.501	10.965	12.573	14.340
9	3.002	4.001	5.014	6.088	7.248	8.512	9.895	11.410	13.075	14.903
10	3.141	4.181	5.233	6.347	7.550	8.859	10.291	11.859	13.581	15.471

Pb-Al 100 keV Number (Flux) Buildup

Flux	1	2	3	4	5	6	7	8	9	10
1	2.511	3.634	4.890	6.310	7.917	9.734	11.782	14.084	16.661	19.539
2	3.185	4.252	5.471	6.866	8.459	10.270	12.319	14.629	17.221	20.121
3	4.127	5.139	6.308	7.662	9.223	11.013	13.049	15.354	17.948	20.857
4	5.516	6.474	7.576	8.868	10.376	12.121	14.124	16.403	18.982	21.883
5	7.632	8.553	9.571	10.774	12.198	13.869	15.807	18.032	20.567	23.434
6	10.951	11.877	12.800	13.881	15.180	16.732	18.561	20.690	23.139	25.931
7	16.271	17.307	18.140	19.064	20.186	21.560	23.217	25.185	27.484	30.140
8	24.962	26.331	27.124	27.867	28.752	29.867	31.264	32.976	35.029	37.451
9	39.389	41.550	42.454	43.029	43.617	44.375	45.387	46.705	48.365	50.400
10	63.677	67.545	68.930	69.451	69.715	70.004	70.468	71.194	72.237	73.648

Pb-AI 500 keV Number (Flux) Buildup

Flux	1	2	3	4	5	6	7	8	9	10
1	3.308	5.744	8.651	12.051	15.966	20.409	25.397	30.939	37.043	43.721
2	3.896	6.655	9.915	13.700	18.028	22.917	28.379	34.423	41.058	48.293
3	4.435	7.508	11.118	15.283	20.027	25.362	31.301	37.854	45.026	52.827
4	4.955	8.339	12.296	16.844	22.004	27.789	34.211	41.278	48.996	57.371
5	5.466	9.163	13.469	18.402	23.983	30.223	37.134	44.723	52.994	61.954
6	5.975	9.988	14.647	19.970	25.976	32.678	40.087	48.205	57.039	66.594
7	6.487	10.819	15.834	21.551	27.990	35.161	43.074	51.733	61.138	71.298
8	7.005	11.658	17.036	23.154	30.032	37.680	46.106	55.314	65.303	76.078
9	7.528	12.510	18.255	24.781	32.105	40.238	49.187	58.953	69.537	80.940
10	8.059	13.374	19.493	26.433	34.212	42.839	52.319	62.655	73.844	85.885

Pb-AI 1 MeV Number (Flux) Buildup

Flux	1	2	3	4	5	6	7	8	9	10
1	3.634	6.086	8.820	11.836	15.124	18.672	22.464	26.486	30.724	35.166
2	4.590	7.455	10.570	13.944	17.574	21.448	25.555	29.880	34.411	39.137
3	5.481	8.758	12.259	16.000	19.980	24.192	28.624	33.264	38.100	43.121
4	6.341	10.030	13.920	18.033	22.372	26.929	31.696	36.659	41.807	47.130
5	7.187	11.290	15.573	20.063	24.766	29.676	34.783	40.077	45.544	51.177
6	8.031	12.550	17.229	22.101	27.174	32.442	37.897	43.526	49.320	55.268
7	8.876	13.814	18.894	24.154	29.603	35.235	41.042	47.014	53.138	59.407
8	9.727	15.089	20.575	26.227	32.056	38.058	44.224	50.543	57.004	63.598
9	10.585	16.375	22.272	28.323	34.537	40.914	47.443	54.115	60.917	67.842
10	11.451	17.676	23.990	30.443	37.049	43.807	50.705	57.734	64.884	72.145

Pb-AI 2 MeV Number (Flux) Buildup

Flux	1	2	3	4	5	6	7	8	9	10
1	3.689	5.700	7.751	9.869	12.053	14.294	16.585	18.917	21.282	23.674
2	4.801	7.088	9.320	11.572	13.860	16.187	18.549	20.941	23.358	25.794
3	5.887	8.467	10.897	13.293	15.694	18.110	20.545	22.999	25.466	27.946
4	6.975	9.859	12.494	15.041	17.557	20.065	22.575	25.089	27.608	30.129
5	8.074	11.269	14.116	16.818	19.452	22.053	24.638	27.213	29.782	32.344
6	9.189	12.703	15.766	18.625	21.379	24.074	26.733	29.369	31.986	34.588
7	10.322	14.161	17.445	20.463	23.338	26.127	28.861	31.556	34.221	36.861
8	11.475	15.646	19.154	22.334	25.331	28.214	31.021	33.775	36.486	39.165
9	12.648	17.155	20.890	24.235	27.354	30.331	33.211	36.021	38.778	41.489
10	13.841	18.690	22.656	26.165	29.408	32.478	35.430	38.297	41.097	43.844

Pb-AI 6 MeV Number (Flux) Buildup

Flux	1	2	3	4	5	6	7	8	9	10
1	3.455	4.674	5.882	7.089	8.292	9.488	10.674	11.848	13.010	14.156
2	4.307	5.468	6.624	7.795	8.971	10.146	11.314	12.472	13.618	14.749
3	5.213	6.327	7.425	8.553	9.696	10.843	11.988	13.125	14.251	15.364
4	6.199	7.264	8.296	9.370	10.471	11.584	12.700	13.811	14.914	16.004
5	7.284	8.291	9.244	10.252	11.301	12.371	13.451	14.531	15.606	16.671
6	8.481	9.419	10.277	11.205	12.190	13.209	14.246	15.289	16.330	17.366
7	9.804	10.659	11.403	12.236	13.145	14.102	15.088	16.086	17.090	18.090
8	11.266	12.021	12.631	13.351	14.170	15.054	15.979	16.926	17.885	18.846
9	12.882	13.519	13.972	14.559	15.271	16.070	16.925	17.813	18.721	19.637
10	14.670	15.165	15.435	15.867	16.456	17.155	17.929	18.750	19.600	20.466

Pb-AI 10 MeV Number (Flux) Buildup

Flux	1	2	3	4	5	6	7	8	9	10
1	3.905	4.826	5.821	6.840	7.865	8.890	9.911	10.926	11.933	12.932
2	5.007	5.657	6.498	7.431	8.402	9.389	10.382	11.375	12.364	13.347
3	6.238	6.611	7.275	8.101	9.003	9.943	10.901	11.866	12.831	13.793
4	7.662	7.723	8.173	8.866	9.681	10.561	11.473	12.402	13.338	14.275
5	9.333	9.028	9.217	9.744	10.450	11.252	12.107	12.992	13.891	14.797
6	11.310	10.566	10.436	10.755	11.324	12.029	12.813	13.642	14.496	15.365
7	13.662	12.388	11.864	11.926	12.323	12.909	13.604	14.364	15.164	15.987
8	16.470	14.550	13.542	13.285	13.468	13.904	14.490	15.166	15.898	16.667
9	19.831	17.124	15.519	14.868	14.786	15.037	15.487	16.061	16.712	17.415
10	23.866	20.195	17.856	16.718	16.309	16.332	16.617	17.065	17.618	18.241

Polyethylene Followed by Lead

Poly-Pb 65 keV Number (Flux) Buildup Factors

Flux	1	2	3	4	5	6	7	8	9	10
1	1.579	1.537	1.571	1.628	1.696	1.770	1.848	1.928	2.011	2.095
2	2.124	1.903	1.867	1.888	1.933	1.985	2.053	2.126	2.204	2.285
3	2.767	2.319	2.198	2.174	2.192	2.225	2.280	2.345	2.416	2.492
4	3.524	2.793	2.569	2.492	2.478	2.488	2.529	2.583	2.647	2.718
5	4.413	3.333	2.985	2.844	2.793	2.777	2.801	2.844	2.899	2.964
6	5.453	3.946	3.450	3.236	3.140	3.095	3.099	3.128	3.174	3.231
7	6.668	4.641	3.971	3.669	3.523	3.443	3.425	3.438	3.472	3.522
8	8.081	5.429	4.552	4.150	3.927	3.824	3.781	3.776	3.797	3.838
9	9.719	6.321	5.202	4.682	4.408	4.242	4.169	4.144	4.151	4.181
10	11.615	7.329	5.927	5.270	4.918	4.700	4.594	4.545	4.535	4.553

Poly-Pb 100 keV Number (Flux) Buildup Factors

Flux	1	2	3	4	5	6	7	8	9	10
1	3.310	4.181	5.458	7.366	10.276	14.830	22.118	34.006	53.732	86.956
2	5.271	6.380	8.267	11.262	16.086	23.792	36.434	57.506	93.139	154.175
3	7.824	9.235	11.964	16.478	23.928	36.064	56.283	90.433	148.853	249.942
4	11.069	12.823	16.627	23.104	33.963	51.873	82.003	133.314	221.719	375.651
5	15.124	17.246	22.374	31.297	46.418	71.568	114.149	187.056	313.256	533.889
6	20.125	22.621	29.344	41.246	61.573	95.579	153.407	252.789	425.361	727.902
7	26.224	29.083	37.696	53.165	79.742	124.392	200.560	331.799	560.199	961.391
8	33.589	36.778	47.604	67.292	101.278	158.554	256.481	425.527	720.192	1238.490
9	42.409	45.870	59.261	83.889	126.567	198.659	322.123	535.539	907.972	1563.700
10	52.890	56.537	72.877	103.241	156.026	245.353	398.518	663.527	1126.370	1941.840

Poly-Pb 500 keV Number (Flux) Buildup Factors

Flux	1	2	3	4	5	6	7	8	9	10
1	1.812	1.969	2.157	2.354	2.556	2.763	2.974	3.190	3.410	3.635
2	2.304	2.332	2.457	2.614	2.788	2.974	3.169	3.371	3.579	3.792
3	2.820	2.707	2.764	2.880	3.025	3.190	3.367	3.554	3.749	3.952
4	3.364	3.096	3.081	3.152	3.267	3.408	3.567	3.739	3.922	4.113
5	3.939	3.501	3.407	3.431	3.514	3.631	3.771	3.927	4.096	4.276
6	4.545	3.920	3.742	3.717	3.765	3.858	3.977	4.118	4.273	4.441
7	5.183	4.355	4.087	4.009	4.022	4.087	4.187	4.311	4.452	4.607
8	5.854	4.806	4.442	4.308	4.283	4.321	4.400	4.506	4.633	4.776
9	6.558	5.273	4.808	4.611	4.554	4.561	4.616	4.702	4.812	4.949
10	7.291	5.752	5.187	4.930	4.823	4.800	4.832	4.908	5.003	5.118

Poly-Pb 1 MeV Number (Flux) Buildup Factors

Flux	1	2	3	4	5	6	7	8	9	10
1	2.146	2.520	2.901	3.281	3.662	4.046	4.433	4.824	5.220	5.621
2	2.791	3.052	3.377	3.723	4.080	4.446	4.820	5.201	5.587	5.980
3	3.458	3.599	3.864	4.173	4.505	4.852	5.211	5.580	5.956	6.341
4	4.152	4.161	4.362	4.631	4.936	5.263	5.605	5.961	6.327	6.702
5	4.873	4.739	4.870	5.096	5.372	5.677	6.003	6.345	6.699	7.064
6	5.621	5.331	5.388	5.569	5.813	6.095	6.403	6.730	7.071	7.426
7	6.395	5.940	5.914	6.047	6.259	6.517	6.806	7.119	7.443	7.787
8	7.192	6.561	6.450	6.533	6.709	6.941	7.211	7.507	7.817	8.149
9	8.013	7.195	6.996	7.025	7.164	7.369	7.617	7.896	8.191	8.512
10	8.856	7.841	7.549	7.522	7.623	7.799	8.025	8.286	8.566	8.873

Poly-Pb 2 MeV Number (Flux) Buildup Factors

Flux	1	2	3	4	5	6	7	8	9	10
1	2.469	3.035	3.607	4.187	4.775	5.373	5.981	6.601	7.230	7.870
2	3.260	3.772	4.326	4.899	5.486	6.086	6.698	7.322	7.956	8.601
3	4.058	4.517	5.050	5.616	6.201	6.802	7.417	8.044	8.681	9.330
4	4.868	5.268	5.780	6.336	6.919	7.520	8.135	8.766	9.404	10.056
5	5.688	6.025	6.514	7.061	7.637	8.237	8.851	9.482	10.126	10.776
6	6.515	6.787	7.251	7.786	8.355	8.953	9.565	10.197	10.842	11.493
7	7.349	7.552	7.988	8.510	9.072	9.666	10.277	10.908	11.553	12.204
8	8.187	8.318	8.725	9.232	9.785	10.376	10.983	11.614	12.258	12.908
9	9.028	9.085	9.461	9.952	10.496	11.081	11.685	12.313	12.956	13.605
10	9.869	9.850	10.194	10.667	11.201	11.780	12.379	13.005	13.646	14.294

Poly-Pb 6 MeV Number (Flux) Buildup Factors

Flux	1	2	3	4	5	6	7	8	9	10
1	3.120	3.888	4.702	5.589	6.565	7.642	8.831	10.146	11.600	13.208
2	4.116	5.015	5.979	7.035	8.197	9.479	10.895	12.458	14.186	16.093
3	5.055	6.089	7.203	8.428	9.775	11.261	12.901	14.704	16.701	18.904
4	5.952	7.120	8.383	9.772	11.301	12.985	14.842	16.884	19.142	21.632
5	6.813	8.113	9.522	11.072	12.776	14.653	16.722	18.994	21.507	24.277
6	7.643	9.071	10.621	12.326	14.201	16.265	18.539	21.035	23.795	26.835
7	8.443	9.994	11.681	13.536	15.577	17.822	20.285	23.007	26.006	29.307
8	9.209	10.877	12.692	14.690	16.886	19.302	21.952	24.880	28.105	31.654
9	9.952	11.735	13.677	15.815	18.165	20.750	23.584	26.715	30.162	33.955
10	10.667	12.561	14.626	16.899	19.397	22.144	25.168	28.483	32.144	36.173

Poly-Pb 10 MeV Number (Flux) Buildup Factors

Flux	1	2	3	4	5	6	7	8	9	10
1	4.070	5.414	6.864	8.530	10.482	12.795	15.553	18.855	22.820	27.593
2	5.179	6.806	8.595	10.663	13.104	16.008	19.493	23.670	28.700	34.768
3	6.185	8.087	10.197	12.649	15.552	19.017	23.186	28.193	34.234	41.535
4	7.124	9.288	11.702	14.517	17.859	21.857	26.675	32.470	39.471	47.942
5	8.009	10.422	13.125	16.287	20.046	24.550	29.983	36.527	44.441	54.024
6	8.847	11.498	14.477	17.967	22.123	27.107	33.127	40.383	49.165	59.806
7	9.644	12.521	15.763	19.565	24.099	29.542	36.120	44.054	53.663	65.312
8	10.403	13.495	16.986	21.088	25.981	31.860	38.969	47.551	57.947	70.557
9	11.126	14.424	18.153	22.538	27.775	34.070	41.686	50.884	62.031	75.556
10	11.815	15.308	19.265	23.921	29.485	36.176	44.277	54.061	65.924	80.323

Lead Followed by Polyethylene (Poly-Pb)

Pb-Poly 65 keV Number Buildup Factors

Flux	1	2	3	4	5	6	7	8	9	10
1	2.794	5.344	9.105	14.372	21.510	30.947	43.174	58.754	78.331	102.637
2	3.009	5.733	9.744	15.354	22.947	32.975	45.954	62.477	83.220	108.954
3	3.216	6.111	10.369	16.316	24.359	34.969	48.692	66.148	88.048	115.198
4	3.420	6.486	10.988	17.271	25.761	36.953	51.417	69.805	92.859	121.422
5	3.623	6.858	11.605	18.225	27.161	38.935	54.143	73.462	97.673	127.654
6	3.826	7.231	12.223	19.179	28.564	40.921	56.872	77.128	102.497	133.900
7	4.029	7.605	12.842	20.137	29.972	42.916	59.616	80.812	107.350	140.184
8	4.232	7.980	13.465	21.098	31.387	44.919	62.372	84.515	112.225	146.499
9	4.437	8.357	14.091	22.066	32.811	46.937	65.149	88.244	117.138	152.864
10	4.643	8.736	14.721	23.041	34.245	48.969	67.945	92.001	122.088	159.277

Pb-Poly 100 keV Number (Flux) Buildup Factors

Flux	1	2	3	4	5	6	7	8	9	10
1	3.452	6.743	11.788	19.045	29.086	42.585	60.318	83.170	112.148	148.385
2	4.626	8.609	14.602	23.059	34.567	49.816	69.600	94.824	126.511	165.821
3	6.237	11.223	18.574	28.752	42.365	60.125	82.849	111.465	147.024	190.707
4	8.573	15.071	24.464	37.232	54.016	75.565	102.727	136.467	177.867	228.144
5	12.089	20.937	33.501	50.300	72.033	99.507	133.627	175.408	225.986	286.629
6	17.535	30.119	47.733	70.972	100.635	137.633	182.964	237.734	303.168	380.620
7	26.166	44.807	70.627	104.367	147.009	199.646	263.442	339.671	429.706	535.056
8	40.116	68.736	108.121	159.282	223.536	302.303	397.058	509.363	640.882	793.396
9	63.039	108.338	170.473	250.959	351.720	474.782	622.182	796.031	998.511	1231.920
10	101.271	174.807	275.589	406.069	569.290	768.385	1006.440	1286.570	1611.940	1985.810

Pb-Poly 500 keV Number (Flux) Buildup Factors

Flux	1	2	3	4	5	6	7	8	9	10
1	3.631	7.348	12.640	19.569	28.211	38.623	50.857	64.954	80.949	98.873
2	4.286	8.555	14.585	22.421	32.122	43.737	57.307	72.865	90.439	110.050
3	4.884	9.678	16.416	25.129	35.865	48.666	63.561	80.574	99.730	121.048
4	5.459	10.766	18.201	27.782	39.548	53.531	69.752	88.229	108.974	132.010
5	6.024	11.843	19.974	30.423	43.222	58.394	75.953	95.908	118.271	143.036
6	6.587	12.921	21.751	33.074	46.915	63.289	82.200	103.652	127.647	154.175
7	7.153	14.005	23.540	35.747	50.642	68.231	88.514	111.485	137.136	165.454
8	7.725	15.100	25.350	38.452	54.416	73.241	94.917	119.430	146.765	176.919
9	8.303	16.210	27.186	41.197	58.247	78.327	101.419	127.502	156.550	188.559
10	8.890	17.337	29.049	43.984	62.139	83.495	108.027	135.708	166.512	200.397

Pb-Poly 1 MeV Number (Flux) Buildup Factors

Flux	1	2	3	4	5	6	7	8	9	10
1	3.984	7.610	12.077	17.241	23.026	29.379	36.260	43.630	51.459	59.712
2	5.052	9.400	14.627	20.537	27.040	34.082	41.622	49.624	58.063	66.903
3	6.044	11.094	17.068	23.724	30.955	38.699	46.915	55.571	64.639	74.086
4	7.000	12.742	19.459	26.864	34.830	43.289	52.197	61.522	71.237	81.307
5	7.942	14.372	21.834	29.992	38.701	47.885	57.498	67.503	77.878	88.585
6	8.879	16.000	24.210	33.127	42.588	52.508	62.836	73.535	84.580	95.936
7	9.818	17.633	26.598	36.283	46.505	57.170	68.224	79.627	91.355	103.370
8	10.764	19.279	29.006	39.468	50.461	61.882	73.673	85.791	98.211	110.897
9	11.717	20.940	31.438	42.686	54.459	66.645	79.179	92.021	105.144	118.508
10	12.679	22.619	33.897	45.941	58.506	71.468	84.760	98.338	112.174	126.228

Pb-Poly 2 MeV Number (Flux) Buildup Factors

Flux	1	2	3	4	5	6	7	8	9	10
1	4.066	6.905	9.828	12.834	15.923	19.088	22.313	25.588	28.899	32.236
2	5.328	8.678	11.938	15.173	18.428	21.719	25.045	28.401	31.778	35.170
3	6.559	10.434	14.051	17.532	20.965	24.390	27.821	31.259	34.704	38.149
4	7.791	12.202	16.187	19.923	23.541	27.105	30.642	34.164	37.675	41.173
5	9.034	13.993	18.357	22.355	26.160	29.864	33.509	37.114	40.690	44.238
6	10.296	15.813	20.563	24.828	28.825	32.671	36.423	40.110	43.749	47.346
7	11.579	17.665	22.807	27.344	31.534	35.522	39.380	43.148	46.848	50.492
8	12.884	19.550	25.092	29.905	34.291	38.421	42.386	46.234	49.993	53.681
9	14.211	21.468	27.415	32.505	37.089	41.363	45.432	49.358	53.175	56.904
10	15.562	23.418	29.777	35.150	39.930	44.346	48.520	52.521	56.394	60.162

Pb-Poly 6 MeV Number (Flux) Buildup Factors

Flux	1	2	3	4	5	6	7	8	9	10
1	3.525	4.836	6.117	7.366	8.574	9.740	10.866	11.952	13.000	14.010
2	4.421	5.622	6.808	7.994	9.156	10.286	11.382	12.441	13.464	14.451
3	5.372	6.472	7.552	8.664	9.772	10.859	11.918	12.946	13.941	14.902
4	6.408	7.397	8.357	9.381	10.424	11.461	12.478	13.470	14.434	15.367
5	7.548	8.410	9.228	10.148	11.116	12.093	13.063	14.014	14.943	15.844
6	8.806	9.520	10.173	10.972	11.850	12.760	13.674	14.580	15.468	16.335
7	10.197	10.738	11.199	11.856	12.631	13.462	14.314	15.168	16.012	16.841
8	11.735	12.075	12.313	12.806	13.462	14.202	14.984	15.780	16.576	17.362
9	13.437	13.544	13.524	13.828	14.347	14.986	15.687	16.419	17.161	17.901
10	15.320	15.156	14.841	14.928	15.291	15.814	16.426	17.085	17.768	18.458

Pb-Poly 10 MeV Number (Flux) Buildup Factors

Flux	1	2	3	4	5	6	7	8	9	10
1	3.547	4.352	5.280	6.191	7.063	7.894	8.688	9.444	10.166	10.854
2	4.533	4.955	5.717	6.547	7.370	8.167	8.934	9.668	10.371	11.043
3	5.637	5.645	6.211	6.941	7.704	8.460	9.196	9.905	10.587	11.240
4	6.915	6.444	6.771	7.379	8.069	8.776	9.476	10.156	10.814	11.447
5	8.417	7.375	7.412	7.869	8.471	9.119	9.776	10.423	11.054	11.663
6	10.194	8.465	8.147	8.420	8.915	9.493	10.099	10.708	11.307	11.891
7	12.309	9.748	8.994	9.043	9.408	9.902	10.449	11.013	11.577	12.133
8	14.833	11.261	9.974	9.748	9.956	10.350	10.827	11.340	11.865	12.388
9	17.854	13.051	11.111	10.551	10.568	10.843	11.239	11.693	12.172	12.658
10	21.477	15.173	12.436	11.468	11.257	11.390	11.690	12.075	12.502	12.947

Stainless Steel Followed by Lead

SS- Pb 65 keV Number (Flux) Buildup Factors

Flux	1	2	3	4	5	6	7	8	9	10
1	1.253	1.335	1.419	1.504	1.590	1.675	1.762	1.849	1.936	2.024
2	1.370	1.444	1.525	1.608	1.693	1.778	1.865	1.952	2.039	2.128
3	1.483	1.553	1.632	1.713	1.797	1.883	1.969	2.056	2.144	2.234
4	1.594	1.661	1.738	1.819	1.903	1.988	2.075	2.162	2.251	2.341
5	1.706	1.770	1.846	1.927	2.010	2.095	2.182	2.270	2.360	2.450
6	1.818	1.880	1.955	2.035	2.118	2.204	2.291	2.380	2.470	2.561
7	1.931	1.991	2.065	2.145	2.228	2.314	2.401	2.491	2.582	2.675
8	2.045	2.104	2.177	2.256	2.340	2.426	2.514	2.604	2.697	2.790
9	2.160	2.217	2.290	2.369	2.453	2.540	2.629	2.719	2.812	2.907
10	2.277	2.333	2.405	2.484	2.568	2.656	2.745	2.837	2.931	3.027

SS- Pb 100 keV Number (Flux) Buildup Factors

Flux	1	2	3	4	5	6	7	8	9	10
1	2.362	3.193	4.263	5.763	7.969	11.333	16.603	25.048	38.843	61.752
2	2.791	3.728	4.955	6.696	9.284	13.265	19.547	29.683	46.342	74.165
3	3.204	4.253	5.637	7.620	10.585	15.171	22.450	34.250	53.729	86.394
4	3.620	4.786	6.331	8.557	11.904	17.103	25.387	38.864	61.185	98.724
5	4.045	5.333	7.044	9.520	13.257	19.083	28.393	43.579	68.791	111.285
6	4.484	5.898	7.782	10.517	14.656	21.126	31.490	48.433	76.610	124.184
7	4.940	6.485	8.548	11.550	16.106	23.242	34.696	53.450	84.687	137.496
8	5.413	7.096	9.345	12.626	17.613	25.441	38.024	58.655	93.061	151.291
9	5.907	7.734	10.177	13.747	19.184	27.732	41.490	64.074	101.774	165.639
10	6.423	8.399	11.044	14.916	20.823	30.121	45.103	69.722	110.854	180.586

SS- Pb 500 keV Number (Flux) Buildup Factors

Flux	1	2	3	4	5	6	7	8	9	10
1	1.827	1.992	2.184	2.385	2.591	2.801	3.016	3.235	3.458	3.685
2	2.338	2.383	2.516	2.681	2.862	3.055	3.256	3.464	3.677	3.897
3	2.877	2.791	2.862	2.989	3.144	3.318	3.503	3.699	3.903	4.114
4	3.450	3.221	3.223	3.309	3.436	3.589	3.759	3.942	4.135	4.336
5	4.059	3.672	3.600	3.641	3.738	3.868	4.021	4.190	4.372	4.564
6	4.707	4.146	3.994	3.986	4.051	4.157	4.291	4.446	4.615	4.797
7	5.393	4.643	4.403	4.344	4.373	4.455	4.570	4.709	4.865	5.036
8	6.121	5.165	4.831	4.716	4.708	4.762	4.856	4.979	5.121	5.281
9	6.890	5.711	5.276	5.102	5.054	5.080	5.151	5.256	5.384	5.532
10	7.701	6.283	5.740	5.501	5.411	5.406	5.455	5.541	5.654	5.789

SS- Pb 1 MeV Number (Flux) Buildup Factors

Flux	1	2	3	4	5	6	7	8	9	10
1	2.153	2.530	2.913	3.295	3.678	4.064	4.453	4.846	5.244	5.646
2	2.806	3.075	3.404	3.754	4.116	4.486	4.864	5.247	5.638	6.034
3	3.484	3.638	3.910	4.226	4.564	4.917	5.281	5.655	6.037	6.426
4	4.193	4.220	4.431	4.709	5.021	5.355	5.705	6.068	6.440	6.821
5	4.932	4.821	4.966	5.202	5.487	5.801	6.136	6.486	6.848	7.221
6	5.702	5.442	5.514	5.707	5.962	6.254	6.572	6.908	7.259	7.623
7	6.502	6.081	6.077	6.223	6.445	6.714	7.013	7.336	7.675	8.028
8	7.331	6.739	6.653	6.749	6.937	7.181	7.461	7.768	8.094	8.437
9	8.188	7.415	7.241	7.284	7.437	7.654	7.914	8.204	8.517	8.848
10	9.073	8.108	7.842	7.830	7.944	8.133	8.370	8.644	8.943	9.262

SS- Pb 2 MeV Number (Flux) Buildup Factors

Flux	1	2	3	4	5	6	7	8	9	10
1	2.458	3.024	3.597	4.177	4.766	5.365	5.974	6.594	7.224	7.864
2	3.249	3.761	4.315	4.889	5.477	6.078	6.691	7.315	7.950	8.596
3	4.058	4.515	5.048	5.614	6.200	6.802	7.417	8.045	8.684	9.334
4	4.890	5.286	5.796	6.351	6.934	7.535	8.152	8.782	9.424	10.077
5	5.743	6.073	6.557	7.100	7.677	8.276	8.893	9.524	10.168	10.823
6	6.616	6.875	7.330	7.859	8.429	9.025	9.640	10.271	10.915	11.571
7	7.508	7.691	8.114	8.627	9.188	9.779	10.392	11.022	11.666	12.322
8	8.416	8.518	8.907	9.402	9.953	10.538	11.147	11.775	12.417	13.072
9	9.337	9.356	9.708	10.183	10.722	11.299	11.903	12.528	13.168	13.822
10	10.272	10.202	10.515	10.969	11.495	12.064	12.662	13.283	13.920	14.572

SS- Pb 6 MeV Number (Flux) Buildup Factors

Flux	1	2	3	4	5	6	7	8	9	10
1	2.950	3.669	4.440	5.283	6.211	7.236	8.369	9.622	11.008	12.542
2	3.878	4.686	5.574	6.551	7.628	8.819	10.135	11.591	13.200	14.978
3	4.829	5.740	6.753	7.873	9.109	10.475	11.985	13.653	15.495	17.530
4	5.810	6.832	7.978	9.248	10.651	12.201	13.913	15.803	17.889	20.191
5	6.826	7.963	9.248	10.675	12.251	13.992	15.914	18.035	20.374	22.953
6	7.875	9.131	10.561	12.149	13.905	15.844	17.983	20.341	22.942	25.807
7	8.956	10.336	11.914	13.669	15.610	17.752	20.115	22.719	25.588	28.748
8	10.068	11.574	13.305	15.231	17.362	19.713	22.305	25.160	28.305	31.767
9	11.209	12.844	14.730	16.832	19.156	21.721	24.548	27.660	31.087	34.858
10	12.377	14.142	16.187	18.468	20.991	23.774	26.840	30.215	33.930	38.016

SS- Pb 10 MeV Number (Flux) Buildup Factors

Flux	1	2	3	4	5	6	7	8	9	10
1	3.901	5.124	6.469	8.017	9.830	11.976	14.533	17.589	21.256	25.665
2	5.003	6.434	8.051	9.933	12.156	14.800	17.962	21.756	26.320	31.820
3	6.130	7.799	9.715	11.963	14.631	17.818	21.641	26.238	31.780	38.471
4	7.305	9.233	11.471	14.113	17.262	21.034	25.570	31.035	37.634	45.613
5	8.539	10.744	13.328	16.393	20.057	24.457	29.758	36.156	43.892	53.259
6	9.837	12.339	15.291	18.808	23.022	28.093	34.214	41.611	50.566	61.419
7	11.205	14.021	17.365	21.361	26.162	31.949	38.942	47.405	57.661	70.103
8	12.646	15.794	19.554	24.058	29.482	36.028	43.950	53.547	65.187	79.319
9	14.161	17.659	21.858	26.901	32.983	40.334	49.240	60.038	73.147	89.072
10	15.752	19.619	24.280	29.892	36.669	44.870	54.816	66.885	81.546	99.368

Lead Followed by Stainless Steel (Pb-SS)

Pb-SS 65 keV Number (Flux) Buildup Factors

Flux	1	2	3	4	5	6	7	8	9	10
1	1.288	1.420	1.543	1.663	1.782	1.901	2.021	2.142	2.265	2.388
2	1.383	1.516	1.640	1.761	1.881	2.002	2.123	2.246	2.370	2.496
3	1.476	1.610	1.736	1.859	1.981	2.103	2.226	2.350	2.476	2.604
4	1.569	1.704	1.832	1.956	2.080	2.204	2.329	2.455	2.583	2.712
5	1.660	1.799	1.928	2.055	2.180	2.306	2.433	2.561	2.691	2.822
6	1.752	1.893	2.025	2.153	2.281	2.409	2.537	2.668	2.799	2.933
7	1.844	1.988	2.122	2.253	2.382	2.512	2.643	2.775	2.909	3.044
8	1.936	2.083	2.220	2.353	2.484	2.616	2.749	2.883	3.019	3.157
9	2.029	2.179	2.318	2.453	2.587	2.722	2.856	2.993	3.131	3.271
10	2.122	2.275	2.417	2.555	2.691	2.828	2.965	3.104	3.244	3.387

Pb-SS 100 keV Number (Flux) Buildup Factors

Flux	1	2	3	4	5	6	7	8	9	10
1	1.506	1.741	2.004	2.276	2.557	2.847	3.147	3.459	3.785	4.124
2	1.725	1.853	2.081	2.340	2.615	2.903	3.204	3.517	3.844	4.186
3	2.039	2.008	2.179	2.415	2.679	2.963	3.262	3.575	3.903	4.247
4	2.511	2.241	2.319	2.513	2.758	3.031	3.325	3.636	3.964	4.308
5	3.252	2.609	2.534	2.655	2.862	3.115	3.398	3.703	4.028	4.371
6	4.444	3.213	2.883	2.879	3.018	3.232	3.492	3.783	4.100	4.439
7	6.407	4.236	3.476	3.252	3.270	3.411	3.627	3.891	4.190	4.519
8	9.697	5.999	4.511	3.902	3.699	3.707	3.839	4.050	4.316	4.622
9	15.292	9.084	6.348	5.059	4.458	4.221	4.198	4.308	4.507	4.770
10	24.926	14.541	9.650	7.153	5.830	5.144	4.831	4.751	4.825	5.004

Pb-SS 500 keV Number (Flux) Buildup Factors

Flux	1	2	3	4	5	6	7	8	9	10
1	2.804	4.298	5.924	7.714	9.678	11.822	14.151	16.669	19.378	22.282
2	3.290	4.948	6.738	8.696	10.834	13.159	15.675	18.386	21.295	24.405
3	3.738	5.563	7.521	9.651	11.967	14.477	17.184	20.093	23.207	26.528
4	4.171	6.165	8.292	10.598	13.095	15.793	18.695	21.806	25.129	28.667
5	4.598	6.763	9.063	11.546	14.228	17.118	20.219	23.537	27.073	30.832
6	5.024	7.362	9.838	12.502	15.372	18.457	21.760	25.288	29.045	33.027
7	5.452	7.966	10.620	13.468	16.529	19.812	23.324	27.065	31.042	35.258
8	5.884	8.578	11.412	14.447	17.703	21.189	24.911	28.872	33.076	37.525
9	6.323	9.198	12.216	15.442	18.896	22.588	26.524	30.708	35.143	39.831
10	6.767	9.827	13.033	16.452	20.109	24.010	28.165	32.577	37.247	42.179

Pb-SS 1 MeV Number (Flux) Buildup Factors

Flux	1	2	3	4	5	6	7	8	9	10
1	3.185	4.874	6.685	8.635	10.725	12.947	15.298	17.773	20.363	23.067
2	3.999	5.918	7.935	10.077	12.348	14.746	17.266	19.903	22.652	25.511
3	4.761	6.917	9.148	11.491	13.953	16.533	19.229	22.036	24.950	27.969
4	5.497	7.895	10.346	12.895	15.553	18.320	21.197	24.180	27.264	30.447
5	6.223	8.867	11.540	14.299	17.157	20.117	23.180	26.342	29.599	32.951
6	6.946	9.839	12.738	15.711	18.773	21.929	25.181	28.526	31.960	35.483
7	7.672	10.815	13.945	17.134	20.405	23.760	27.204	30.735	34.351	38.047
8	8.402	11.799	15.162	18.572	22.053	25.612	29.252	32.973	36.770	40.646
9	9.139	12.793	16.392	20.026	23.721	27.486	31.325	35.238	39.222	43.278
10	9.883	13.798	17.637	21.498	25.410	29.384	33.425	37.533	41.706	45.945

Pb-SS 2 MeV Number (Flux) Buildup Factors

Flux	1	2	3	4	5	6	7	8	9	10
1	3.302	4.835	6.410	8.044	9.735	11.481	13.275	15.112	16.986	18.895
2	4.266	5.965	7.660	9.389	11.161	12.976	14.831	16.722	18.644	20.597
3	5.211	7.093	8.919	10.751	12.608	14.495	16.412	18.358	20.329	22.324
4	6.157	8.231	10.195	12.135	14.080	16.040	18.021	20.021	22.041	24.078
5	7.114	9.385	11.492	13.542	15.577	17.612	19.657	21.712	23.780	25.858
6	8.084	10.559	12.811	14.974	17.099	19.210	21.318	23.429	25.542	27.662
7	9.071	11.752	14.152	16.430	18.647	20.834	23.006	25.170	27.330	29.489
8	10.075	12.968	15.518	17.912	20.222	22.484	24.719	26.937	29.142	31.340
9	11.095	14.203	16.906	19.417	21.819	24.158	26.455	28.725	30.975	33.210
10	12.133	15.459	18.317	20.946	23.441	25.855	28.215	30.537	32.831	35.103

Pb-SS 6 MeV Number (Flux) Buildup Factors

Flux	1	2	3	4	5	6	7	8	9	10
1	3.403	4.578	5.768	7.002	8.282	9.607	10.977	12.388	13.838	15.324
2	4.246	5.432	6.627	7.869	9.162	10.502	11.887	13.314	14.778	16.278
3	5.142	6.357	7.561	8.811	10.114	11.465	12.862	14.301	15.777	17.288
4	6.119	7.369	8.582	9.837	11.145	12.504	13.909	15.356	16.841	18.359
5	7.194	8.482	9.700	10.955	12.264	13.625	15.034	16.484	17.973	19.496
6	8.379	9.708	10.927	12.176	13.479	14.836	16.242	17.692	19.180	20.703
7	9.689	11.059	12.272	13.508	14.798	16.144	17.542	18.985	20.468	21.987
8	11.138	12.547	13.748	14.962	16.230	17.558	18.940	20.370	21.842	23.351
9	12.741	14.188	15.368	16.550	17.788	19.088	20.447	21.857	23.311	24.804
10	14.513	15.996	17.146	18.284	19.480	20.743	22.070	23.452	24.882	26.353

Pb-SS 10 MeV Number (Flux) Buildup Factors

Flux	1	2	3	4	5	6	7	8	9	10
1	4.306	5.484	6.693	7.972	9.329	10.765	12.285	13.889	15.580	17.359
2	5.558	6.647	7.796	9.045	10.393	11.835	13.370	14.997	16.715	18.525
3	6.948	7.982	9.074	10.289	11.623	13.066	14.611	16.257	17.999	19.837
4	8.553	9.542	10.572	11.743	13.052	14.487	16.037	17.696	19.458	21.320
5	10.436	11.380	12.335	13.448	14.720	16.136	17.681	19.346	21.122	23.005
6	12.662	13.559	14.420	15.455	16.673	18.056	19.584	21.245	23.027	24.924
7	15.312	16.151	16.894	17.826	18.967	20.298	21.795	23.440	25.218	27.120
8	18.475	19.244	19.836	20.632	21.669	22.924	24.369	25.981	27.742	29.638
9	22.264	22.943	23.344	23.963	24.858	26.007	27.375	28.933	30.659	32.535
10	26.813	27.376	27.534	27.924	28.633	29.637	30.896	32.375	34.043	35.881

Aluminum followed by Stainless Steel (Al-SS)

Al-SS 65 keV Number (Flux) Buildup

Flux	1	2	3	4	5	6	7	8	9	10
1	1.561	1.628	1.725	1.831	1.943	2.058	2.176	2.296	2.419	2.543
2	1.959	1.965	2.034	2.127	2.232	2.343	2.459	2.580	2.704	2.831
3	2.392	2.336	2.376	2.454	2.550	2.656	2.771	2.891	3.016	3.146
4	2.865	2.744	2.753	2.814	2.900	3.001	3.113	3.233	3.359	3.491
5	3.386	3.194	3.169	3.210	3.285	3.380	3.489	3.608	3.735	3.869
6	3.960	3.690	3.626	3.646	3.708	3.796	3.900	4.019	4.148	4.283
7	4.595	4.236	4.131	4.124	4.173	4.251	4.353	4.471	4.598	4.737
8	5.294	4.838	4.685	4.650	4.683	4.751	4.848	4.964	5.091	5.234
9	6.065	5.501	5.295	5.229	5.243	5.299	5.391	5.505	5.632	5.777
10	6.914	6.231	5.965	5.864	5.857	5.901	5.985	6.097	6.224	6.372

Al-SS 100 keV Number (Flux) Buildup

Flux	1	2	3	4	5	6	7	8	9	10
1	1.925	2.133	2.377	2.639	2.915	3.205	3.508	3.826	4.159	4.507
2	2.550	2.656	2.858	3.101	3.369	3.657	3.963	4.288	4.630	4.990
3	3.239	3.233	3.387	3.606	3.863	4.148	4.457	4.787	5.138	5.510
4	4.003	3.870	3.969	4.160	4.404	4.683	4.992	5.328	5.687	6.070
5	4.852	4.574	4.607	4.765	4.991	5.265	5.573	5.912	6.279	6.671
6	5.798	5.350	5.308	5.427	5.631	5.895	6.200	6.541	6.916	7.317
7	6.849	6.207	6.077	6.149	6.327	6.578	6.878	7.220	7.600	8.011
8	8.014	7.150	6.919	6.936	7.083	7.317	7.610	7.954	8.336	8.756
9	9.305	8.188	7.840	7.794	7.904	8.118	8.400	8.741	9.127	9.554
10	10.733	9.328	8.847	8.727	8.795	8.983	9.253	9.587	9.977	10.410

Al-SS 500 keV Number (Flux) Buildup

Flux	1	2	3	4	5	6	7	8	9	10
1	3.595	5.036	6.646	8.426	10.379	12.509	14.820	17.315	19.995	22.864
2	5.178	6.704	8.445	10.370	12.474	14.761	17.229	19.883	22.726	25.759
3	6.979	8.570	10.433	12.497	14.749	17.188	19.811	22.624	25.626	28.822
4	9.014	10.644	12.615	14.811	17.205	19.792	22.567	25.536	28.697	32.053
5	11.291	12.930	14.997	17.315	19.845	22.575	25.500	28.622	31.939	35.455
6	13.817	15.433	17.580	20.011	22.670	25.540	28.610	31.882	35.354	39.026
7	16.597	18.157	20.367	22.901	25.684	28.688	31.900	35.319	38.942	42.771
8	19.634	21.103	23.360	25.988	28.886	32.019	35.369	38.932	42.706	46.688
9	22.932	24.274	26.561	29.272	32.278	35.535	39.018	42.723	46.643	50.777
10	26.495	27.675	29.973	32.755	35.862	39.237	42.849	46.693	50.758	55.042

Al-SS 1 MeV Number (Flux) Buildup

Flux	1	2	3	4	5	6	7	8	9	10
1	3.737	5.351	7.119	9.034	11.088	13.275	15.588	18.022	20.571	23.230
2	5.416	7.139	9.035	11.077	13.254	15.557	17.982	20.521	23.170	25.925
3	7.268	9.082	11.093	13.252	15.541	17.953	20.482	23.121	25.864	28.709
4	9.287	11.172	13.286	15.550	17.944	20.457	23.082	25.814	28.646	31.576
5	11.466	13.401	15.604	17.964	20.455	23.061	25.777	28.596	31.511	34.520
6	13.794	15.762	18.042	20.489	23.068	25.762	28.562	31.462	34.455	37.537
7	16.264	18.246	20.592	23.118	25.778	28.552	31.431	34.407	37.471	40.623
8	18.867	20.847	23.249	25.845	28.579	31.427	34.379	37.425	40.557	43.773
9	21.596	23.558	26.005	28.664	31.466	34.382	37.401	40.512	43.707	46.982
10	24.442	26.372	28.856	31.570	34.433	37.412	40.493	43.664	46.917	50.248

Al-SS 2 MeV Number (Flux) Buildup

Flux	1	2	3	4	5	6	7	8	9	10
1	3.670	5.158	6.716	8.338	10.020	11.756	13.540	15.366	17.230	19.127
2	5.169	6.718	8.340	10.022	11.757	13.541	15.366	17.230	19.125	21.049
3	6.732	8.333	10.012	11.747	13.530	15.355	17.217	19.113	21.035	22.983
4	8.352	9.995	11.725	13.506	15.331	17.193	19.088	21.011	22.957	24.924
5	10.020	11.699	13.471	15.294	17.155	19.050	20.973	22.919	24.886	26.869
6	11.729	13.435	15.246	17.105	18.998	20.921	22.868	24.835	26.817	28.814
7	13.472	15.200	17.043	18.933	20.854	22.802	24.769	26.753	28.749	30.755
8	15.243	16.986	18.857	20.775	22.721	24.689	26.673	28.671	30.677	32.691
9	17.036	18.790	20.685	22.626	24.592	26.577	28.576	30.581	32.595	34.614
10	18.847	20.607	22.521	24.482	26.463	28.462	30.472	32.488	34.509	36.530

Al-SS 6 MeV Number (Flux) Buildup

Flux	1	2	3	4	5	6	7	8	9	10
1	3.832	5.107	6.366	7.651	8.975	10.339	11.743	13.185	14.664	16.176
2	5.071	6.416	7.742	9.092	10.476	11.897	13.354	14.846	16.369	17.924
3	6.277	7.706	9.106	10.522	11.968	13.445	14.954	16.493	18.059	19.653
4	7.465	8.984	10.459	11.942	13.448	14.979	16.538	18.122	19.731	21.362
5	8.641	10.251	11.801	13.349	14.913	16.498	18.105	19.734	21.379	23.047
6	9.807	11.505	13.129	14.741	16.364	17.997	19.651	21.322	23.005	24.708
7	10.960	12.747	14.441	16.117	17.794	19.477	21.175	22.887	24.605	26.341
8	12.101	13.972	15.738	17.475	19.201	20.936	22.677	24.422	26.180	27.941
9	13.227	15.181	17.016	18.811	20.589	22.369	24.152	25.933	27.725	29.516
10	14.336	16.372	18.273	20.125	21.953	23.777	25.600	27.417	29.241	31.060

Al-SS 10 MeV Number (Flux) Buildup

Flux	1	2	3	4	5	6	7	8	9	10
1	4.432	5.867	7.244	8.650	10.113	11.645	13.255	14.945	16.720	18.581
2	5.676	7.229	8.721	10.242	11.822	13.473	15.202	17.013	18.909	20.891
3	6.861	8.555	10.174	11.818	13.519	15.290	17.139	19.071	21.087	23.190
4	8.019	9.861	11.611	13.380	15.203	17.095	19.065	21.116	23.254	25.476
5	9.160	11.153	13.036	14.930	16.876	18.888	20.975	23.143	25.402	27.742
6	10.289	12.432	14.449	16.468	18.534	20.665	22.870	25.160	27.530	29.987
7	11.408	13.701	15.850	17.992	20.177	22.425	24.747	27.153	29.638	32.210
8	12.515	14.957	17.236	19.500	21.804	24.168	26.604	29.124	31.723	34.407
9	13.612	16.200	18.607	20.992	23.412	25.890	28.439	31.072	33.781	36.577
10	14.697	17.430	19.963	22.466	25.001	27.592	30.252	32.995	35.814	38.719

Stainless Steel followed by Aluminum (SS-Al)

SS-Al 65 keV Exposure Buildup

Flux	1	2	3	4	5	6	7	8	9	10
1	1.952	2.639	3.352	4.120	4.959	5.881	6.897	8.018	9.254	10.618
2	2.143	2.871	3.625	4.435	5.319	6.290	7.358	8.535	9.833	11.263
3	2.325	3.098	3.894	4.748	5.679	6.699	7.820	9.055	10.415	11.913
4	2.504	3.322	4.163	5.062	6.040	7.110	8.286	9.579	11.003	12.570
5	2.683	3.547	4.433	5.378	6.404	7.526	8.757	10.110	11.598	13.235
6	2.862	3.774	4.705	5.697	6.772	7.946	9.234	10.647	12.201	13.910
7	3.043	4.002	4.980	6.019	7.145	8.372	9.717	11.193	12.814	14.596
8	3.226	4.233	5.258	6.346	7.523	8.805	10.209	11.747	13.437	15.293
9	3.410	4.467	5.540	6.678	7.906	9.244	10.706	12.309	14.069	16.000
10	3.597	4.705	5.826	7.014	8.296	9.690	11.214	12.882	14.713	16.722

SS-Al 100 keV Exposure Buildup

Flux	1	2	3	4	5	6	7	8	9	10
1	2.543	3.839	5.253	6.829	8.597	10.583	12.808	15.299	18.079	21.174
2	3.022	4.456	6.014	7.745	9.681	11.849	14.275	16.984	20.001	23.356
3	3.485	5.069	6.780	8.675	10.787	13.147	15.783	18.720	21.987	25.614
4	3.949	5.691	7.565	9.632	11.931	14.493	17.349	20.526	24.055	27.967
5	4.423	6.331	8.375	10.622	13.116	15.890	18.976	22.405	26.208	30.419
6	4.913	6.993	9.215	11.652	14.350	17.346	20.674	24.366	28.456	32.981
7	5.419	7.682	10.091	12.726	15.638	18.867	22.448	26.416	30.807	35.660
8	5.945	8.399	11.004	13.848	16.984	20.456	24.303	28.562	33.269	38.463
9	6.494	9.148	11.957	15.019	18.391	22.119	26.244	30.805	35.842	41.398
10	7.067	9.930	12.954	16.245	19.862	23.858	28.273	33.152	38.534	44.468

SS-Al 500 keV Exposure Buildup

Flux	1	2	3	4	5	6	7	8	9	10
1	4.427	7.071	10.151	13.703	17.753	22.318	27.414	33.051	39.237	45.982
2	6.483	9.763	13.445	17.588	22.230	27.393	33.095	39.347	46.157	53.538
3	8.776	12.770	17.112	21.893	27.166	32.960	39.297	46.190	53.650	61.687
4	11.325	16.103	21.160	26.625	32.567	39.025	46.026	53.588	61.721	70.436
5	14.137	19.769	25.596	31.788	38.437	45.593	53.289	61.546	70.376	79.793
6	17.218	23.775	30.426	37.390	44.785	52.672	61.092	70.071	79.623	89.764
7	20.574	28.124	35.653	43.435	51.613	60.265	69.440	79.167	89.467	100.356
8	24.209	32.823	41.286	49.931	58.933	68.384	78.344	88.849	99.922	111.584
9	28.127	37.876	47.329	56.884	66.749	77.034	87.811	99.122	110.994	123.452
10	32.332	43.290	53.789	64.300	75.067	86.222	97.847	109.993	122.691	135.970

SS-Al 1 MeV Exposure Buildup

Flux	1	2	3	4	5	6	7	8	9	10
1	4.421	6.871	9.586	12.577	15.835	19.347	23.098	27.074	31.262	35.649
2	6.559	9.451	12.519	15.818	19.357	23.129	27.123	31.328	35.731	40.322
3	8.911	12.274	15.701	19.305	23.118	27.141	31.370	35.795	40.405	45.191
4	11.474	15.327	19.117	23.024	27.104	31.371	35.827	40.464	45.273	50.247
5	14.237	18.599	22.755	26.962	31.305	35.810	40.485	45.326	50.327	55.481
6	17.190	22.077	26.604	31.109	35.708	40.445	45.332	50.370	55.555	60.881
7	20.325	25.754	30.655	35.455	40.307	45.270	50.363	55.591	60.953	66.446
8	23.631	29.618	34.896	39.991	45.093	50.275	55.568	60.980	66.513	72.165
9	27.101	33.661	39.319	44.707	50.052	55.450	60.936	66.526	72.223	78.027
10	30.729	37.875	43.918	49.597	55.183	60.791	66.465	72.227	78.081	84.032

SS-Al 2 MeV Exposure Buildup

Flux	1	2	3	4	5	6	7	8	9	10
1	4.192	6.132	8.146	10.241	12.408	14.634	16.909	19.226	21.575	23.950
2	6.032	8.127	10.236	12.404	14.631	16.908	19.225	21.575	23.952	26.349
3	7.966	10.215	12.411	14.643	16.921	19.239	21.590	23.968	26.366	28.779
4	9.989	12.387	14.661	16.949	19.269	21.621	23.999	26.398	28.811	31.233
5	12.092	14.635	16.979	19.313	21.668	24.047	26.445	28.858	31.281	33.706
6	14.267	16.950	19.357	21.729	24.113	26.512	28.924	31.346	33.773	36.198
7	16.505	19.324	21.787	24.192	26.596	29.010	31.430	33.856	36.282	38.703
8	18.801	21.751	24.263	26.694	29.114	31.535	33.959	36.383	38.802	41.216
9	21.146	24.223	26.779	29.229	31.658	34.082	36.504	38.923	41.333	43.735
10	23.535	26.736	29.330	31.794	34.227	36.649	39.065	41.473	43.870	46.256

SS-Al 6 MeV Exposure Buildup

Flux	1	2	3	4	5	6	7	8	9	10
1	3.840	5.054	6.275	7.489	8.695	9.892	11.077	12.250	13.409	14.551
2	5.089	6.213	7.389	8.576	9.761	10.939	12.107	13.261	14.402	15.526
3	6.353	7.404	8.535	9.691	10.851	12.006	13.152	14.286	15.405	16.507
4	7.654	8.632	9.714	10.834	11.963	13.091	14.211	15.321	16.416	17.494
5	8.998	9.898	10.925	12.003	13.096	14.193	15.284	16.364	17.433	18.485
6	10.385	11.200	12.166	13.195	14.249	15.309	16.367	17.417	18.456	19.481
7	11.815	12.538	13.435	14.411	15.419	16.440	17.462	18.478	19.485	20.479
8	13.285	13.908	14.730	15.646	16.605	17.582	18.565	19.544	20.516	21.478
9	14.793	15.308	16.048	16.900	17.804	18.734	19.674	20.615	21.552	22.479
10	16.337	16.737	17.389	18.172	19.018	19.897	20.792	21.690	22.588	23.480

SS-Al 10 MeV Exposure Buildup

Flux	1	2	3	4	5	6	7	8	9	10
1	4.054	5.073	6.124	7.171	8.212	9.245	10.271	11.289	12.297	13.295
2	5.235	6.083	7.059	8.065	9.077	10.089	11.096	12.097	13.090	14.073
3	6.425	7.133	8.037	8.997	9.977	10.964	11.949	12.931	13.905	14.870
4	7.659	8.233	9.061	9.971	10.914	11.870	12.830	13.787	14.740	15.685
5	8.952	9.388	10.134	10.988	11.887	12.808	13.738	14.668	15.596	16.518
6	10.312	10.601	11.257	12.048	12.898	13.779	14.674	15.574	16.473	17.369
7	11.743	11.874	12.431	13.151	13.947	14.782	15.638	16.504	17.372	18.239
8	13.249	13.210	13.658	14.300	15.033	15.819	16.632	17.459	18.294	19.129
9	14.831	14.608	14.938	15.493	16.159	16.888	17.653	18.439	19.235	20.037
10	16.492	16.071	16.271	16.731	17.323	17.991	18.703	19.443	20.199	20.963

Polyethylene Followed by Stainless Steel (Poly-SS)

Poly-SS 65 keV Exposure Buildup

Flux	1	2	3	4	5	6	7	8	9	10
1	1.668	1.668	1.736	1.826	1.926	2.032	2.143	2.257	2.374	2.494
2	2.243	2.067	2.066	2.118	2.197	2.287	2.389	2.497	2.609	2.728
3	2.917	2.520	2.436	2.444	2.495	2.569	2.659	2.760	2.866	2.981
4	3.707	3.036	2.850	2.805	2.825	2.878	2.955	3.046	3.147	3.258
5	4.632	3.621	3.313	3.205	3.189	3.217	3.278	3.359	3.452	3.559
6	5.712	4.286	3.832	3.650	3.589	3.590	3.632	3.700	3.784	3.886
7	6.969	5.039	4.411	4.142	4.030	3.998	4.018	4.072	4.146	4.241
8	8.428	5.892	5.059	4.687	4.515	4.445	4.440	4.477	4.539	4.627
9	10.117	6.856	5.781	5.290	5.050	4.935	4.902	4.919	4.968	5.046
10	12.066	7.945	6.588	5.958	5.638	5.472	5.405	5.400	5.433	5.501

Poly-SS 100 keV Exposure Buildup

Flux	1	2	3	4	5	6	7	8	9	10
1	1.952	2.121	2.346	2.594	2.858	3.136	3.429	3.736	4.058	4.396
2	2.634	2.635	2.789	2.999	3.239	3.504	3.787	4.089	4.411	4.749
3	3.410	3.201	3.271	3.435	3.648	3.895	4.168	4.465	4.781	5.119
4	4.298	3.827	3.795	3.905	4.084	4.311	4.570	4.858	5.171	5.506
5	5.314	4.520	4.366	4.411	4.552	4.753	4.996	5.273	5.580	5.911
6	6.476	5.289	4.988	4.957	5.051	5.223	5.446	5.711	6.008	6.335
7	7.802	6.140	5.665	5.545	5.585	5.722	5.921	6.171	6.457	6.778
8	9.312	7.082	6.404	6.178	6.156	6.252	6.424	6.653	6.929	7.241
9	11.027	8.123	7.207	6.860	6.765	6.815	6.956	7.165	7.424	7.726
10	12.968	9.273	8.080	7.594	7.417	7.413	7.517	7.699	7.942	8.232

Poly-SS 500 keV Exposure Buildup

Flux	1	2	3	4	5	6	7	8	9	10
1	3.589	5.021	6.624	8.396	10.341	12.463	14.764	17.249	19.918	22.776
2	5.166	6.667	8.391	10.299	12.386	14.653	17.102	19.735	22.555	25.564
3	6.962	8.505	10.337	12.372	14.596	17.004	19.595	22.374	25.341	28.499
4	8.990	10.541	12.466	14.619	16.972	19.515	22.245	25.166	28.278	31.581
5	11.259	12.780	14.780	17.041	19.514	22.187	25.052	28.111	31.363	34.810
6	13.773	15.224	17.282	19.638	22.224	25.020	28.014	31.208	34.597	38.184
7	16.535	17.875	19.971	22.410	25.102	28.014	31.133	34.456	37.979	41.704
8	19.548	20.734	22.848	25.359	28.146	31.169	34.407	37.855	41.512	45.365
9	22.815	23.802	25.912	28.478	31.349	34.490	37.840	41.406	45.181	49.164
10	26.331	27.072	29.177	31.789	34.739	37.957	41.414	45.095	49.023	53.135

Poly-SS 1 MeV Exposure Buildup

Flux	1	2	3	4	5	6	7	8	9	10
1	3.734	5.345	7.111	9.023	11.075	13.258	15.568	17.999	20.545	23.200
2	5.411	7.125	9.015	11.051	13.222	15.519	17.937	20.470	23.112	25.860
3	7.260	9.056	11.057	13.205	15.485	17.887	20.405	23.034	25.766	28.600
4	9.275	11.130	13.227	15.477	17.857	20.355	22.967	25.685	28.502	31.416
5	11.447	13.339	15.518	17.859	20.331	22.919	25.617	28.417	31.313	34.302
6	13.765	15.674	17.923	20.345	22.900	25.573	28.342	31.222	34.197	37.245
7	16.222	18.124	20.434	22.931	25.555	28.305	31.160	34.098	37.141	40.269
8	18.806	20.687	23.044	25.605	28.297	31.116	34.039	37.041	40.147	43.336
9	21.511	23.354	25.748	28.366	31.118	34.001	36.987	40.048	43.212	46.456
10	24.327	26.116	28.538	31.204	34.010	36.950	39.993	43.108	46.326	49.621

Poly-SS 2 MeV Exposure Buildup

Flux	1	2	3	4	5	6	7	8	9	10
1	3.670	5.162	6.723	8.347	10.029	11.765	13.549	15.375	17.239	19.135
2	5.162	6.719	8.345	10.030	11.766	13.550	15.376	17.239	19.135	21.058
3	6.711	8.322	10.007	11.746	13.530	15.357	17.220	19.115	21.038	22.985
4	8.308	9.963	11.701	13.487	15.313	17.177	19.073	20.996	22.943	24.910
5	9.943	11.636	13.419	15.248	17.114	19.011	20.936	22.885	24.852	26.836
6	11.609	13.332	15.155	17.022	18.922	20.849	22.799	24.768	26.753	28.750
7	13.299	15.047	16.905	18.806	20.735	22.688	24.660	26.647	28.646	30.654
8	15.007	16.774	18.663	20.594	22.550	24.525	26.516	28.518	30.528	32.545
9	16.729	18.509	20.426	22.382	24.362	26.356	28.363	30.377	32.397	34.419
10	18.458	20.249	22.188	24.168	26.167	28.179	30.198	32.222	34.249	36.276

Poly-SS 6 MeV Exposure Buildup

Flux	1	2	3	4	5	6	7	8	9	10
1	3.895	5.222	6.506	7.808	9.145	10.522	11.937	13.389	14.877	16.398
2	5.153	6.590	7.965	9.350	10.764	12.211	13.692	15.202	16.746	18.314
3	6.337	7.894	9.366	10.837	12.325	13.842	15.383	16.954	18.551	20.168
4	7.467	9.145	10.715	12.270	13.833	15.417	17.023	18.647	20.295	21.958
5	8.552	10.351	12.016	13.653	15.288	16.938	18.599	20.281	21.978	23.686
6	9.597	11.513	13.270	14.986	16.692	18.405	20.123	21.856	23.601	25.351
7	10.605	12.633	14.480	16.273	18.046	19.820	21.593	23.376	25.166	26.957
8	11.575	13.713	15.646	17.512	19.350	21.183	23.008	24.839	26.673	28.504
9	12.511	14.753	16.769	18.707	20.607	22.496	24.378	26.249	28.125	29.994
10	13.412	15.755	17.851	19.857	21.817	23.761	25.691	27.607	29.523	31.427

Poly-SS 10 MeV Exposure Buildup

Flux	1	2	3	4	5	6	7	8	9	10
1	4.508	6.052	7.490	8.943	10.449	12.022	13.670	15.399	17.212	19.110
2	5.765	7.501	9.105	10.716	12.376	14.103	15.905	17.791	19.757	21.809
3	6.906	8.840	10.613	12.381	14.194	16.071	18.023	20.058	22.172	24.373
4	7.969	10.098	12.035	13.955	15.916	17.939	20.034	22.213	24.470	26.814
5	8.971	11.288	13.382	15.450	17.553	19.715	21.948	24.263	26.657	29.138
6	9.920	12.417	14.662	16.871	19.110	21.405	23.769	26.217	28.741	31.352
7	10.823	13.491	15.882	18.224	20.593	23.016	25.506	28.079	30.729	33.465
8	11.682	14.514	17.043	19.514	22.006	24.551	27.162	29.855	32.624	35.479
9	12.501	15.489	18.149	20.743	23.355	26.015	28.742	31.550	34.433	37.403
10	13.281	16.418	19.205	21.916	24.640	27.412	30.248	33.166	36.159	39.238

Stainless Steel Followed by Polyethylene (SS-Poly)

SS-Poly 65 keV Exposure Buildup

Flux	1	2	3	4	5	6	7	8	9	10
1	2.902	5.515	9.361	14.740	22.020	31.633	44.077	59.920	79.814	104.497
2	3.192	6.030	10.198	16.014	23.871	34.231	47.620	64.643	85.991	112.447
3	3.467	6.524	11.006	17.251	25.676	36.769	51.091	69.280	92.068	120.284
4	3.737	7.012	11.806	18.477	27.468	39.294	54.546	73.902	98.131	128.109
5	4.005	7.498	12.605	19.705	29.263	41.825	58.015	78.543	104.224	135.977
6	4.273	7.986	13.409	20.940	31.070	44.374	61.509	83.223	110.369	143.915
7	4.544	8.479	14.220	22.186	32.895	46.951	65.042	87.954	116.583	151.946
8	4.817	8.976	15.039	23.447	34.743	49.559	68.619	92.746	122.880	160.084
9	5.093	9.479	15.868	24.723	36.612	52.198	72.240	97.598	129.256	168.326
10	5.372	9.989	16.710	26.018	38.510	54.880	75.920	102.530	135.739	176.708

SS-Poly 100 keV Exposure Buildup

Flux	1	2	3	4	5	6	7	8	9	10
1	3.282	6.620	11.794	19.320	29.826	44.048	62.833	87.145	118.075	156.854
2	3.924	7.777	13.729	22.350	34.334	50.498	71.774	99.226	134.052	177.603
3	4.539	8.906	15.633	25.348	38.817	56.936	80.729	111.361	150.144	198.550
4	5.152	10.044	17.564	28.399	43.388	63.514	89.897	123.804	166.666	220.086
5	5.778	11.210	19.547	31.537	48.097	70.299	99.360	136.660	183.750	242.368
6	6.423	12.416	21.599	34.788	52.980	77.339	109.185	150.014	201.505	265.537
7	7.091	13.668	23.733	38.169	58.061	84.667	119.417	163.926	220.007	289.688
8	7.784	14.970	25.955	41.694	63.359	92.312	130.094	178.446	239.324	314.905
9	8.509	16.329	28.274	45.374	68.893	100.298	141.249	193.620	259.511	341.267
10	9.263	17.749	30.696	49.218	74.675	108.642	152.907	209.480	280.613	368.825

SS-Poly 500 keV Exposure Buildup

Flux	1	2	3	4	5	6	7	8	9	10
1	4.951	9.399	15.494	23.212	32.593	43.684	56.534	71.184	87.673	106.033
2	7.362	13.372	21.300	30.995	42.438	55.645	70.648	87.483	106.185	126.784
3	10.059	17.832	27.807	39.691	53.396	68.904	86.227	105.398	126.447	149.418
4	13.064	22.800	35.038	49.323	65.491	83.483	103.294	124.950	148.480	173.934
5	16.387	28.287	43.005	59.907	78.738	99.400	121.867	146.159	172.304	200.366
6	20.035	34.303	51.722	71.455	93.155	116.673	141.965	169.048	197.961	228.738
7	24.013	40.856	61.196	83.980	108.753	135.316	163.605	193.630	225.439	259.069
8	28.328	47.953	71.442	97.498	125.554	155.355	186.816	219.942	254.784	291.398
9	32.984	55.603	82.469	112.022	143.573	176.806	211.614	248.004	286.019	325.769
10	37.986	63.814	94.287	127.564	162.824	199.686	238.020	277.826	319.167	362.164

SS-Poly 1 MeV Exposure Buildup

Flux	1	2	3	4	5	6	7	8	9	10
1	4.972	8.874	13.485	18.696	24.473	30.787	37.608	44.903	52.646	60.802
2	7.517	12.593	18.198	24.228	30.699	37.621	44.988	52.785	60.994	69.585
3	10.332	16.693	23.357	30.237	37.408	44.932	52.835	61.119	69.778	78.786
4	13.409	21.156	28.938	36.693	44.572	52.694	61.123	69.879	78.971	88.382
5	16.736	25.963	34.918	43.575	52.169	60.884	69.825	79.041	88.553	98.349
6	20.299	31.092	41.274	50.856	60.172	69.479	78.925	88.589	98.507	108.675
7	24.087	36.531	47.990	58.522	68.567	78.459	88.408	98.508	108.820	119.348
8	28.089	42.263	55.046	66.552	77.333	87.813	98.246	108.772	119.465	130.338
9	32.293	48.273	62.426	74.927	86.451	97.515	108.431	119.373	130.435	141.641
10	36.693	54.550	70.117	83.635	95.909	107.551	118.949	130.298	141.718	153.246

SS-Poly 2 MeV Exposure Buildup

Flux	1	2	3	4	5	6	7	8	9	10
1	4.736	7.560	10.427	13.387	16.442	19.578	22.778	26.027	29.312	32.623
2	6.960	10.264	13.352	16.435	19.575	22.775	26.024	29.311	32.624	35.954
3	9.305	13.108	16.407	19.600	22.809	26.059	29.345	32.659	35.989	39.329
4	11.764	16.075	19.580	22.868	26.134	29.421	32.732	36.062	39.400	42.741
5	14.325	19.154	22.855	26.227	29.536	32.849	36.175	39.511	42.849	46.182
6	16.977	22.332	26.223	29.667	33.009	36.337	39.668	43.001	46.330	49.650
7	19.710	25.597	29.672	33.178	36.542	39.875	43.203	46.525	49.838	53.136
8	22.515	28.939	33.191	36.751	40.127	43.457	46.772	50.076	53.365	56.636
9	25.383	32.348	36.772	40.376	43.755	47.073	50.368	53.646	56.906	60.144
10	28.307	35.817	40.407	44.047	47.422	50.720	53.987	57.234	60.458	63.658

SS-Poly 6 MeV Exposure Buildup

Flux	1	2	3	4	5	6	7	8	9	10
1	3.958	5.221	6.495	7.735	8.933	10.088	11.204	12.279	13.316	14.316
2	5.301	6.378	7.545	8.716	9.860	10.970	12.045	13.083	14.085	15.051
3	6.656	7.565	8.623	9.718	10.803	11.863	12.893	13.890	14.855	15.786
4	8.048	8.788	9.728	10.740	11.760	12.765	13.747	14.701	15.626	16.520
5	9.487	10.048	10.860	11.781	12.730	13.675	14.605	15.513	16.396	17.251
6	10.974	11.343	12.017	12.840	13.712	14.593	15.468	16.327	17.166	17.981
7	12.506	12.672	13.198	13.916	14.704	15.518	16.334	17.142	17.935	18.709
8	14.083	14.032	14.401	15.005	15.706	16.448	17.203	17.957	18.703	19.433
9	15.701	15.421	15.623	16.108	16.717	17.382	18.074	18.772	19.468	20.155
10	17.357	16.837	16.863	17.223	17.734	18.321	18.946	19.587	20.232	20.873

SS-Poly 10 MeV Exposure Buildup

Flux	1	2	3	4	5	6	7	8	9	10
1	3.710	4.585	5.534	6.445	7.310	8.134	8.918	9.666	10.379	11.058
2	4.789	5.375	6.203	7.042	7.856	8.639	9.390	10.107	10.793	11.448
3	5.877	6.196	6.897	7.659	8.417	9.156	9.869	10.554	11.212	11.841
4	7.005	7.053	7.620	8.296	8.993	9.684	10.357	11.007	11.634	12.236
5	8.188	7.952	8.372	8.955	9.585	10.223	10.852	11.466	12.060	12.634
6	9.432	8.893	9.154	9.636	10.192	10.773	11.356	11.930	12.491	13.034
7	10.742	9.878	9.967	10.339	10.816	11.335	11.868	12.401	12.926	13.437
8	12.119	10.908	10.811	11.064	11.455	11.909	12.389	12.878	13.365	13.844
9	13.566	11.984	11.687	11.810	12.110	12.494	12.918	13.360	13.808	14.252
10	15.084	13.106	12.594	12.579	12.781	13.091	13.456	13.849	14.255	14.664

Appendix 4: Dose Fit Parameters

The following tables present the fit parameters for equation 5.10 in the text for dose buildup factors:

$$B(x,y) = \frac{a + bx + cy^2}{f + dx + ex^2 + gy + hy^2}$$

There are three sets of fit parameters for each configuration and energy. “Low Material 2” represents shields of 1-10 mfp of the first shielding material and 1-5 mfp of the second shielding material. “High Material 2” represents shields of 1-10 mfp of the first material followed by 6-10 mfp of the second material. “Full Shield” represents 1-10 mfp of the first material followed by 1-10 mfp of the second material.

Aluminum followed by Lead

Al Pb							
Low Material 2	65	100(log fit)	500	1	2	6	10
a	3365.346	1290.396176	1303.196	525.8943	114373.7	18855.66	2546.016
b	542.4428	207.8570895	1393.361	239.3223	29486.02	3623.4	399.3518
c	36.46253	60.49370875	110.5556	41.81734	6571.835	516.0147	81.14774
d	313.9594	-197.7147757	619.3497	51.015	767.0461	-362.905	-137.774
e	-13.6243	4.913262896	-27.0236	-2.61248	-74.7197	-0.37008	3.526891
f	2821.912	3565.282173	1342.231	410.6317	78864.39	14151.35	1909.813
g	-501.834	-259.0041407	-255.452	-42.2039	-6887.53	-1744.25	-164.747
h	36.43981	46.45010221	38.27796	9.018343	1224.427	173.5504	17.08415
high Material 2	65	100(log fit)	500	1	2	6	10
a	4260.8	5869.020231	0.052002	6468.306	717.299	32388.07	2205.394
b	786.3487	14.94618888	4.714006	2136.636	89.27573	4051.455	348.6981
c	126.2261	42.48679524	0.194036	26.26709	12.15627	200.135	17.94984
d	478.7106	-785.2666686	1.839057	513.2834	1.334541	-571.227	-84.6662
e	-24.213	27.22239281	-0.06695	-22.026	-0.32619	11.24882	2.375195
f	2270.537	8244.335047	0.772951	3365.427	291.9224	15211.9	1159.368
g	-44.6279	-155.1843627	0.000439	-360.415	-10.8	-939.562	-51.879
h	4.830181	18.34446083	0.01406	13.87633	1.145808	42.20801	2.331751
Full Shield	65	100(log fit)	500	1	2	6	10
a	4130.215	1290.396176	293662.8	282.4502	7894.667	28983.79	17358.27
b	438.0913	207.8570895	234296.5	160.825	2076.392	5971.993	3268.436
c	52.181	60.49370875	8529.501	7.87556	199.4051	261.7446	235.0034
d	274.0124	-197.7147757	98724.58	40.37606	163.3664	-316.506	-803.646
e	-14.0913	4.913262896	-4002.99	-1.86641	-9.89112	-4.60907	21.59704
f	2910.232	3565.282173	247772.3	208.9265	4776.315	19064.18	11881.67
g	-328.676	-259.0041407	-35829.9	-24.0572	-379.085	-1845	-764.841
h	16.51726	46.45010221	2449.145	1.767114	32.49751	98.60564	42.98956

Lead followed by Aluminum

Pb Al							
Low Material 2	65	100(log fit)	500	1	2	6	10
a	131.8305	2301.181037	16.71297394	34.77475	8090.786	653.0277	27730.82
b	63.65827	4959.156111	15.81488452	27.98512	4877.544	227.3597	9056.828
c	1.774027	839.0224479	0.715327702	1.599069	409.2203	33.27526	1794.992
d	-3.15213	3477.604659	-0.84610141	-0.7046	13.65669	2.956679	984.0565
e	-0.02498	-109.7179088	0.023736603	0.016747	-0.6829	-0.07856	-57.7893
f	111.1328	16782.48107	16.01670671	29.90858	6426.057	530.1599	23212.47
g	-4.35679	500.2158267	-1.014090233	-2.66186	-575.05	-21.3746	-564.209
h	0.324051	476.1464258	0.084284573	0.238223	63.28511	5.879475	356.1196
High Material 2	65	100(log fit)	500	1	2	6	10
a	200.5946	-22.57210645	5942.097417	440.9165	59.96822	599.4294	-72.9039
b	100.8794	2.372327864	5784.49627	292.1612	28.80225	432.3863	250.2843
c	0.753641	1.105417036	58.70622209	2.485691	0.259808	33.19068	9.114929
d	-3.10903	1.552544355	-184.5404914	-1.45352	0.984389	56.47002	78.78365
e	-0.06752	-0.041151461	4.853761121	0.007138	-0.02979	-2.59987	-3.33378
f	157.1157	-54.69654262	4672.933023	251.9306	31.19698	477.2954	24.27567
g	-5.37698	14.91285758	-225.6756366	-17.1827	-2.50638	12.36169	12.83979
h	0.166221	-0.448508695	7.703792385	0.594452	0.087632	1.65904	-0.48552
Full Shield	65	100(log fit)	500	1	2	6	10
a	61.22135	4672.908164	19749.65439	604370.5	60880.34	34844.12	1611.672
b	31.58807	15971.98249	-2278.096019	516561.9	37162.99	21399.97	5033.369
c	0.373368	1817.913588	205.0187571	8099.117	898.6287	1590.957	154.3408
d	-1.21301	12018.84007	-778.4584519	-3577.56	920.0092	2735.063	1625.973
e	-0.016	-310.7859934	35.82370744	17.08385	-27.0204	-125.08	-72.5265
f	51.62663	36033.20534	4032.443675	475102.5	42825.08	31099.29	3099.551
g	-1.935	7446.614443	30.62337422	-38866.2	-3755.72	-1116.4	-219.697
h	0.080085	-94.84842266	3.562474437	1786.195	189.325	185.122	12.23197

Polyethylene followed by lead

Poly-Pb							
Low Material 2	65	100(log fit)	500	1	2	6	10
a	3254.125	9612.457423	3614.693	5737.282	1054.422	759.6603	2295.258
b	1447.625	1310.855657	4507.708	2641.768	271.2414	151.4314	391.474
c	128.3273	577.2097457	364.4367	461.1142	59.69399	19.09425	67.19932
d	1066.032	-1288.50773	2043.331	568.0139	7.019174	-12.8515	-112.673
e	-43.6224	25.06179313	-88.9114	-29.0672	-0.67947	-0.07991	2.642733
f	2719.868	24317.6801	3900.664	4493.014	725.9051	562.6364	1688.544
g	-729.398	-1910.840698	-749.239	-458.191	-64.0181	-74.2979	-163.496
h	68.03397	387.4922445	123.4369	99.96818	11.30609	7.451831	17.28804
High Material 2	65	100(log fit)	500	1	2	6	10
a	-46096	6965.158201	-2.92382	7883.454	24.50898	235.7944	2121.978
b	103417.5	-417.6965983	33.1417	2700.287	2.699683	31.29273	329.0393
c	6769.154	61.78337776	1.266078	32.71405	0.410702	1.194602	13.21356
d	54613.05	-917.4280647	13.10447	655.6929	-0.02866	-3.77872	-74.0109
e	-1851.02	30.22327769	-0.46395	-28.0102	-0.00803	0.066107	1.96627
f	-26869.1	7505.261297	3.588553	4139.791	9.795907	107.433	1033.68
g	6590.525	-41.8730687	0.059058	-444.088	-0.33607	-6.6439	-44.4139
h	-293.45	18.59257825	0.097551	17.21618	0.038649	0.299268	2.072313
Full Shield	65	100(log fit)	500	1	2	6	10
a	6105.932	27255.21996	25501.85	125688.9	6992.309	6603.651	39369.95
b	1906.344	5768.683843	24204.34	74126.24	1821.868	1398.644	7846.922
c	146.6161	624.2706372	840.0115	3572.274	170.348	51.924	448.9517
d	1518.083	-201.1003646	10382.08	18824.11	140.7433	-62.9909	-1622.02
e	-70.1541	-96.16852274	-414.387	-867.722	-8.49237	-1.42124	38.60128
f	3739.794	60997.52468	22608.11	94031.93	4216.243	4252.206	25990.09
g	-640.88	-4762.982043	-3371.55	-10878.3	-337.791	-421.727	-1772.74
h	31.78993	451.3136747	241.3198	809.3347	28.73127	22.99557	103.791

Lead followed by polyethylene

Pb-Poly							
Low Material 2	65	100 (log fit)	500	1	2	6	10
a	-4.63877	1290.396176	17.77728838	10.84077	1985.979	2769.245	690.9837
b	8.289172	207.8570895	32.25093339	11.46648	1403.182	1067.204	223.1085
c	0.273324	60.49370875	1.653849714	0.634587	106.0335	151.2444	41.52964
d	-0.40115	-197.7147757	-2.298833334	-0.38284	11.53066	44.67086	23.04102
e	0.016028	4.913262896	0.083711973	0.012204	-0.34739	-0.52253	-0.77377
f	3.037984	3565.282173	26.85962739	10.81877	1671.386	2290.181	587.4352
g	-0.0414	-259.0041407	-1.325580427	-0.92339	-155.396	-80.7346	-9.46962
h	0.003501	46.45010221	0.115464326	0.08189	16.45815	29.57762	10.37262
High Material 2	65	100(log fit)	500	1	2	6	10
a	-1252.15	5869.020231	457.4139313	1359.408	73.70623	142.7468	-77.5284
b	1524.587	14.94618888	1120.03515	1198.365	41.57725	362.0252	106.5661
c	15.08677	42.48679524	13.88620193	10.49264	0.23633	15.42057	2.062595
d	-56.7432	-785.266686	-50.94496679	-14.6809	1.590968	77.50362	40.60006
e	2.257104	27.22239281	1.834642537	0.465701	-0.04644	-3.09208	-1.58038
f	450.3737	8244.335047	703.5018181	885.0462	40.15721	207.2607	-26.1659
g	-5.31347	-155.1843627	-26.21996924	-57.635	-3.42512	2.658415	5.019354
h	0.188071	18.34446083	0.933007098	2.012452	0.114995	1.014992	-0.16501
Full Shield	65	100(log fit)	500	1	2	6	10
a	-45.4072	4672.908164	112.7333815	25393.79	15.96151	8792.571	-866.607
b	59.53232	15971.98249	326.4520512	29545.96	11.66441	9735.286	5739.708
c	0.901282	1817.913588	6.424866412	468.2328	0.221714	568.1511	79.9707
d	-2.5524	12018.84007	-18.00333775	-467.993	0.351094	1890.341	2240.214
e	0.102951	-310.7859934	0.668507421	14.5602	-0.0099	-78.3977	-92.6193
f	19.63924	36033.20534	231.8459426	23727.22	11.98393	9723.751	1410.66
g	-0.2534	7446.614443	-10.22839729	-1851.21	-1.11168	-376.871	-193.334
h	0.012021	-94.84842266	0.48400953	85.63643	0.053374	77.00357	9.465009

Aluminum followed by Stainless Steel

AI-SS							
Low Material 2	65	100 (log fit)	500	1	2	6	10
a	1574.986	4029.976145	11.6245	101.5984	20626.45	4588.538	5098.175
b	293.6668	1647.244474	4.424116	44.04896	8463.352	1438.614	1388.123
c	13.95239	156.9240794	1.012716	8.729929	1461.77	188.0716	132.0752
d	129.948	467.4027721	-0.28252	-1.89037	-171.247	-2.25721	-2.09006
e	-5.83614	-26.00170231	0.006491	0.046062	3.865588	-0.87759	-2.46279
f	1278.556	3109.334103	6.547682	62.3372	13566.34	3389.446	3983.338
g	-225.676	-544.143742	-0.45081	-4.82209	-1148.83	-338.126	-427.198
h	15.42216	50.40478458	0.066018	0.719908	176.2707	42.0472	43.06347
High Material 2	65	100 (log fit)	500	1	2	6	10
a	4457.023	695.7197206	124572.4	257.9224	1009.776	55.50024	12.52162
b	412.2689	126.8678912	21020.92	51.60356	201.8563	11.18867	2.49131
c	42.18459	4.806742348	3776.107	5.72863	15.19893	0.348091	0.051354
d	193.2058	32.3168737	-1857.93	-2.59798	-5.01514	0.070181	-0.00543
e	-10.8999	-1.836127145	42.06959	0.068013	0.161691	-0.00306	-0.0021
f	2439.631	322.0345189	35348.42	78.38094	352.4015	25.92013	6.76674
g	-207.588	-35.47039823	-626.013	-2.89776	-17.2135	-1.73022	-0.47052
h	7.870228	1.313008506	69.95052	0.218156	1.150199	0.07972	0.01902
Full Shield	65	100 (log fit)	500	1	2	6	10
a	1468.277	8599.509693	4610.868	167076.7	3191.054	2158.478	29505.05
b	167.2575	2338.959171	1523.666	56268.7	1049.427	698.8488	9011.568
c	16.61439	162.5453136	222.3264	7001.141	99.95776	25.95884	176.9858
d	73.93555	614.439491	-69.0832	-2167.36	-15.5551	26.85634	427.0519
e	-3.99409	-35.46583467	0.853556	49.28752	0.371238	-1.25341	-27.7911
f	989.8417	5224.440913	2086.244	79208.7	1676.747	1411.419	21285.2
g	-110.492	-633.2198774	-107.524	-4621.37	-114.056	-131.456	-2105.08
h	5.309805	32.61083855	8.970118	399.9644	9.668494	7.582437	103.09

Stainless steel followed by aluminum

SS-Al							
Low Material 2	65	100 (log fit)	500	1	2	6	10
a	100357.7	20.76189406	44.08355444	178.9738	244638.9	587.3423	4262.536
b	45985.38	16.92854041	30.32596472	99.2197	109034.5	188.3313	1090.316
c	1681.03	0.963387814	4.820663825	16.91436	18891.78	34.4028	214.4134
d	-2355.12	-0.831787885	-1.479180877	-3.59077	-1620.48	3.323465	35.73277
e	-12.5333	0.015268367	0.043512763	0.100373	49.03206	-0.05983	-1.49535
f	81089.65	17.81696486	30.17925825	116.8738	162497.2	440.5595	3355.832
g	-3714.31	-1.124562668	-2.58215799	-10.0231	-13753.2	-29.5576	-186.504
h	293.3599	0.091931852	0.276280686	1.299541	2153.891	6.281589	46.18048
high Material 2	65	100 (log fit)	500	1	2	6	10
a	1559.667	138.3356538	122.0281174	654.5824	93435.01	17.74502	404.7119
b	730.0479	116.6261182	71.61877019	243.5276	23067.46	3.299977	110.0861
c	6.883802	1.699112994	2.349106873	10.17354	1494.759	0.454174	10.5572
d	-21.9812	-3.154372169	-0.654379253	-0.48875	-38.3985	-0.00149	13.48301
e	-0.43194	0.042041048	0.006886502	-0.02244	3.430621	-0.0013	-0.63204
f	1130.083	97.43539846	46.9645673	222.6151	33484.95	8.502997	240.7536
g	-44.3021	-5.075772285	-3.621613128	-15.7096	-1812.73	-0.1024	-3.23241
h	1.405809	0.169134824	0.141206965	0.699359	112.5152	0.03686	0.982064
Full Shield	65	100 (log fit)	500	1	2	6	10
a	8675.305	52908.33014	3.016137536	7014.666	11598.55	5399.266	10484.1
b	4254.686	48872.44489	1.931057201	3007.435	3972.012	1756.733	3738.505
c	63.65558	1110.707597	0.138806808	284.4197	419.6411	186.9192	324.1541
d	-160.902	-1775.232357	-0.064848601	-99.2985	-67.1049	96.38173	521.8113
e	-1.83015	34.27371821	0.002183588	3.460598	2.75231	-3.65556	-22.5547
f	6937.795	45332.53931	1.646028884	3440.414	6073.156	3668.341	8116.974
g	-301.439	-2641.777252	-0.123320802	-234.967	-391.254	-199.609	-443.892
h	12.85956	115.6532553	0.00670162	16.44183	35.6428	25.58037	53.18794

Stainless steel followed by lead

SS-Pb							
Low Material 2	65	100 (log fit)	500	1	2	6	10
a	11604.17	568.9648825	497.9782	732.6102	126.2517	12243.27	1.36E+06
b	1523.887	183.4084122	376.6874	312.7024	32.5983	2211.972	199958.2
c	93.25505	18.53354194	30.4006	55.76032	7.371908	376.6892	45442.43
d	528.1073	-80.02886028	158.2422	63.52883	0.817561	-281.906	-76411
e	-19.3832	0.67515927	-6.983	-3.27322	-0.08176	1.521755	2021.694
f	10728.82	2206.648135	468.4137	563.8459	87.3122	9299.842	1.04E+06
g	-764.973	-91.61954802	-83.9532	-57.8272	-7.52482	-1016.95	-83306.6
h	68.27451	17.30305936	10.95591	11.87892	1.342064	100.7613	8042.522
High Material 2	65	100 (log fit)	500	1	2	6	10
a	152.8465	287.6602542	62.83458	366.3846	141.586	1426.727	39.72751
b	5.592583	32.26162317	87.40847	109.669	20.01512	158.4463	6.265618
c	0.935009	1.595497277	4.114023	1.294137	2.450601	12.19932	0.497043
d	-0.96776	-42.51386537	33.27231	25.42143	0.732742	-29.8517	-1.76138
e	-0.0266	1.140124932	-1.31576	-1.09968	-0.08352	0.679258	0.053433
f	115.902	667.4353808	47.62274	186.8013	58.95273	691.8823	22.82135
g	-3.13909	-11.37543695	-2.78685	-19.8663	-2.3407	-39.6469	-1.00093
h	0.281168	1.07989026	0.372656	0.745516	0.227098	1.780754	0.042118
Full Shield	65	100 (log fit)	500	1	2	6	10
a	121952.4	9797.370658	4227.436	22220.11	2351.958	5008.224	16400.47
b	18961.97	3012.133419	2370.221	11421.94	624.6881	963.3059	2608.865
c	-294.484	130.0448399	100.4546	592.3152	62.11739	58.02503	289.7499
d	7610.689	-711.6173799	950.0097	2759.574	49.42173	-71.658	-874.413
e	-242.809	-19.48889034	-40.113	-128.723	-3.0077	-0.10596	27.10482
f	112488.2	33344.80419	3286.53	15960.35	1430.178	3360.846	11393.74
g	-8897.51	-1165.761492	-436.809	-1790.41	-111.741	-303.225	-659.103
h	180.6699	118.0037404	28.41202	129.3086	9.617116	15.88314	35.03433

Lead followed by stainless steel

Pb-SS							
Low Material 2	65	100 (log fit)	500	1	2	6	10
a	17412.48	994964.8389	742.7159068	123.7176	8869.265	4474.246	16837.27
b	3116.339	-1.49E+06	506.7040317	83.06286	4805.786	1372.397	3841.61
c	64.2096	-66967.79796	22.06520188	5.00776	430.0865	201.0498	865.12
d	824.7281	-4.75E+06	-20.70963953	-1.75486	-17.0883	-44.9547	-124.986
e	-29.5737	241612.5724	0.379018055	0.027881	-0.34206	0.159232	-10.9084
f	16121.53	989544.3763	628.0024866	100.0126	6875.116	3563.238	12984.85
g	-1034.45	155.3700923	-43.9745048	-8.92689	-599.283	-172.946	-465.89
h	62.41298	-53269.80404	3.587623242	0.813509	66.84333	30.89384	111.871
High Material 2	65	100 (log fit)	500	1	2	6	10
a	46.73105	-11.33525037	617.9396095	275.5214	2953.033	1006.257	40.87925
b	6.826668	3.429554019	401.1883768	150.5808	1267.224	269.9517	24.30386
c	0.005205	0.259810238	3.649514132	1.346478	15.34822	26.98986	2.341458
d	1.501029	8.812473557	-8.725602348	-0.14432	35.4556	-2.86618	3.262558
e	-0.04879	-0.253318425	0.113271242	-0.02752	-1.18703	-0.27145	-0.20937
f	40.06657	-45.71619238	415.1175945	149.9779	1508.245	604.8659	31.06313
g	-2.09865	8.940524255	-22.46224354	-10.3182	-114.819	-1.965	1.546604
h	0.04923	-0.392260848	0.747487074	0.356712	4.156948	1.059968	-0.08254
Full Shield	65	100 (log fit)	500	1	2	6	10
a	44255.04	-692.5434828	3473.115012	33066.91	6694.225	7778.747	4262.687
b	9180.778	774.858477	2590.588814	23244.61	3644.35	2660.905	2154.612
c	-63.0434	39.86129654	38.34472166	380.5665	101.0204	242.3926	170.3004
d	2859.683	2351.516369	-65.77787899	-33.7613	69.5366	43.0169	311.5189
e	-96.9857	-100.0886177	0.912570863	-6.02914	-2.44536	-5.29331	-19.3493
f	41100.25	-1942.991685	2853.615327	24259.61	4587.534	5896.266	3715.551
g	-2759.21	525.4939993	-182.0358205	-2004.55	-387.084	-223.09	-147.389
h	58.99367	-26.57622361	7.997316697	92.30277	20.03838	22.93237	7.123144

Polyethylene followed by stainless steel

Poly-SS							
Low Material 2	65	100(keV)	500	1	2	6	10
a	117.1313	1670.61148	38.5367	22.66078	42542.51	7920.424	3666.416
b	50.32415	1437.738084	14.51222	9.794538	17568.01	2627.602	1089.243
c	3.632785	83.54915843	3.347258	1.945716	2965.94	281.7097	72.84767
d	30.99768	528.2442048	-0.93661	-0.42237	-333.9	34.87369	21.42824
e	-1.36791	-27.18370408	0.021117	0.010228	7.261045	-2.88203	-2.60771
f	95.68492	1523.563415	21.63136	13.8907	28000.42	5838.313	2864.497
g	-24.6567	-363.7148157	-1.44425	-1.06395	-2401.56	-668.157	-368.66
h	2.142631	33.38644754	0.219521	0.160919	365.0029	76.53595	35.26531
High Material 2	65	100 keV	500	1	2	6	10
a	-1231.18	-4.134478833	378.2973	2663.781	308.0533	466.9443	2644.342
b	1545.354	10.53107622	60.334	521.199	62.17928	104.8199	593.7437
c	104.8753	0.556458362	11.49736	59.2048	4.320386	1.779945	6.005003
d	698.1899	3.278865037	-5.70697	-27.4052	-1.3955	2.317541	7.787291
e	-26.5341	-0.153221221	0.122845	0.711389	0.045925	-0.08134	-0.77249
f	-539.895	0.099513883	106.0844	806.0545	107.5071	216.975	1398.747
g	128.9233	0.215163509	-1.54845	-28.9668	-5.45823	-15.8896	-102.04
h	-5.37464	-0.00143873	0.215119	2.264318	0.35179	0.669822	4.030144
Full Shield	65	100 keV	500	1	2	6	10
a	8498.476	3630.697587	171182.3	98843.32	14092.95	18070.49	61933.28
b	2631.22	2000.069962	57834.26	33435.61	4713.664	6461.85	19755.1
c	189.7487	81.84769348	8312.765	4143.19	420.4757	133.7865	224.5711
d	1742.518	699.391822	-2370.16	-1254.17	-55.6411	355.1162	995.8448
e	-85.8311	-35.81718211	16.69391	27.0163	1.18575	-15.3239	-60.7953
f	5179.003	2428.760641	78104.04	46954.98	7423.306	11863.68	43837.13
g	-856.847	-390.3021492	-3994.29	-2729.78	-520.364	-1243.49	-4650.32
h	42.29931	19.89197117	345.847	239.4793	42.952	65.89766	230.4715

Stainless steel followed by polyethylene

SS-Poly							
Low Material 2	65 (log fit)	100 (log fit)	500	1	2	6	10
a	35.62986	400.1692858	18.95154236	20.00285	5783.49	14796.75	744.2583
b	125.2059	1037.698615	48.35206509	17.5429	3054.514	5240.552	229.971
c	1.418532	21.55760994	6.325805657	2.414237	481.847	997.9087	44.82978
d	37.28432	267.5905278	-2.33569796	-0.49893	-14.0802	250.2099	21.17911
e	-0.62576	-3.597506095	0.087442165	0.015719	0.55482	-3.45617	-0.41826
f	305.0305	2703.889257	32.79720536	16.24825	4030.082	11303.01	611.4412
g	-12.3556	-167.1162938	-2.763169665	-1.53489	-360.863	-654.652	-25.4934
h	1.41079	20.96922733	0.265744509	0.174782	54.23844	191.1823	11.0286
High Material 2	65(Log fit)	100 (log fit)	500 (regular fit)	1	2	6	10
a	2404.644	20050.08782	4654.558399	2915.515	12674.37	151.8792	94.54931
b	4283.566	21804.78781	13524.87728	1961.598	4548.059	67.52761	82.26393
c	11.3488	93.6063068	315.7059447	29.05628	139.0725	5.484599	1.672907
d	1229.897	5191.005824	-172.9280253	23.45875	144.7915	9.231705	23.02832
e	-19.4594	-56.99657626	6.126569813	-0.99376	-4.25202	-0.33518	-0.77734
f	11149.54	62910.46994	5265.556387	1203.591	4906.548	88.94918	80.2861
g	-319.244	-2371.360462	-408.7830502	-113.882	-377.849	-1.47853	-5.92181
h	13.11733	101.2023743	15.65666536	4.299571	17.27447	0.535233	0.348954
Full Shield	65(log fit)	100 (log fit)	500	1	2	6	10
a	318.2542	504.5099188	0.975070825	30.38541	16876.05	3409.978	7111.418
b	840.0301	912.907486	6.654394088	24.80306	6709.969	1718.5	6669.063
c	3.885235	7.114688717	0.286944891	1.26246	635.478	160.1521	334.5367
d	249.1891	237.0059281	-0.161561764	-0.27455	-63.9099	224.2284	1814.031
e	-4.22227	-3.407172909	0.006533291	0.01242	4.577531	-8.00293	-66.6561
f	2094.933	2445.407579	3.266891573	19.37381	9110.953	2606.247	7335.978
g	-73.6221	-123.7581209	-0.270302005	-1.72115	-622.714	-140.545	-496.257
h	4.390347	7.821381405	0.013247409	0.095439	53.94392	23.69402	68.75328

Appendix 5: Exposure Fit Parameters

The following tables present the fit parameters for equation 5.10 in the text for dose buildup factors:

$$B(x,y) = \frac{a + bx + cy^2}{f + dx + ex^2 + gy + hy^2}$$

There are three sets of fit parameters for each configuration and energy. “Low Material 2” represents shields of 1-10 mfp of the first shielding material and 1-5 mfp of the second shielding material. “High Material 2” represents shields of 1-10 mfp of the first material followed by 6-10 mfp of the second material. “Full Shield” represents 1-10 mfp of the first material followed by 1-10 mfp of the second material.

Aluminum followed by lead

Al-Pb							
Low Material 2							
	65	100 log	500	1	2	6	10
a	40625.42	333466.4	2024.31	2506.956	30255.25	92883.4	2749.753
b	6631.003	38028.46	2120.474	1110.782	7805.833	17689.78	420.2968
c	439.7198	13361.79	170.2674	195.6004	1732.47	2513.04	86.62135
d	3236.023	-46647.3	943.0731	236.5577	202.2513	-1782.74	-150.342
e	-140.218	1161.793	-41.1396	-12.115	-19.6462	-2.84696	3.842634
f	28337.63	782155.6	2075.878	1963.087	20941.09	70360.4	2084.325
g	-5100.83	-52583.4	-388.47	-198.615	-1830.89	-8671.82	-179.398
h	370.9683	9756.267	58.86552	42.70962	324.4926	861.9574	18.6265
High Material 2							
	65	100	500	1	2	6	10
a	8445.43	404.7713	723.2483	2318.73	1215.719	18940.64	1082.051
b	1827.647	-7.91791	12662.81	759.8913	147.4769	2343.836	166.6075
c	293.562	2.761245	520.5136	9.213367	20.73728	116.3377	8.718336
d	924.3731	-53.8244	4959.468	184.1343	1.245594	-337.249	-42.0935
e	-46.176	1.866999	-180.954	-7.87976	-0.50922	6.61663	1.18152
f	3665.336	517.3684	2409.371	1220.911	494.9797	9002.713	575.6455
g	-12.0548	-7.83988	-29.2687	-129.878	-17.7946	-555.584	-25.6981
h	6.723028	1.099353	39.53854	4.982168	1.939389	24.96414	1.156459
Full Shield							
	65	100	500	1	2	6	10
a	12581.32	3113.264	1184.171	17115.57	20786.23	4907.346	4998.447
b	1357.803	539.2808	937.0085	9582.165	5439.132	1005.015	922.5406
c	162.3309	46.28575	34.22905	473.1262	523.5845	43.70111	66.85147
d	721.2974	-151.071	395.3015	2424.182	421.5103	-52.812	-233.334
e	-37.0783	-2.31791	-16.0155	-111.94	-25.5599	-0.85128	6.238317
f	7352.225	6695.933	1001.567	12738.06	12610.83	3263.446	3461.779
g	-836.694	-435.727	-143.449	-1449.16	-997.95	-316.264	-222.969
h	42.24392	37.84535	9.854421	107.126	85.60441	16.88003	12.53528

Lead followed by aluminum

Pb-Al							
Low Material 2							
	65	100 log	500	1	2	6	10
a	4459.567	2075.514	30.47865	299.8585	1040.167	801.0673	77828.98
b	2184.315	4514.61	25.65736	220.5236	597.4429	274.9714	24651.34
c	60.3367	751.7246	1.172817	12.84331	51.42878	39.99535	4864.911
d	-105.289	3171.655	-1.4166	-5.63665	1.497832	3.790854	2594.124
e	-0.89007	-99.7779	0.038346	0.127731	-0.07592	-0.09747	-152.212
f	3743.896	15527.33	28.19137	253.9189	822.3443	657.7068	65777.15
g	-147.084	448.4429	-1.81012	-22.5968	-72.8397	-26.4752	-1591.66
h	10.9064	429.9109	0.150475	2.031435	8.124528	7.25351	989.824
High Material 2							
	65	100	500	1	2	6	10
a	1794.475	-321.665	-80.4263	364.5737	50.71011	174.8841	-713.814
b	916.1441	34.82832	-68.7263	221.5147	23.08124	120.4652	3108.997
c	6.771853	15.80751	-0.70452	1.936478	0.231591	9.304107	109.9995
d	-27.3328	22.87265	2.26156	-1.05107	0.78786	15.89525	995.5897
e	-0.6213	-0.60174	-0.05705	0.00084	-0.02346	-0.7319	-42.0169
f	1400.547	-789.062	-60.665	207.5054	26.36947	138.9446	432.0265
g	-48.0384	216.4382	2.96854	-14.1394	-2.08099	3.506237	145.5026
h	1.481857	-6.58587	-0.10124	0.48946	0.073605	0.485001	-5.53685
Full Shield							
	65	100	500	1	2	6	10
a	23690.97	68.88094	13312.32	113137.7	17092.16	2432.363	9261.245
b	12405.01	246.6159	-1537.28	88129.5	9866.064	1456.921	27083.85
c	145.2128	27.67306	139.3134	1406.328	253.5341	107.8449	819.6417
d	-463.034	186.8019	-558.689	-543.821	241.7538	189.5563	8898.819
e	-6.40571	-4.83116	25.5976	-1.78809	-6.98467	-8.63248	-395.766
f	19906.61	561.6607	2900.552	87501.72	11950.89	2183.829	17325.38
g	-747.673	115.5747	22.7611	-7166.41	-1031.66	-78.3272	-1217.36
h	30.87403	-1.65889	2.672886	329.5617	52.79207	12.93263	67.60572

Polyethylene followed by lead

Poly-Pb							
Low Material 2							
	65	100	500	1	2	6	10
a	2302.071	2572.545	320.2897	9514.299	1744.384	50161.23	2302.071
b	383.0588	278.8352	390.2339	4263.928	449.1033	9903.671	383.0588
c	66.62498	136.6523	31.94051	750.0149	98.42342	1247.369	66.62498
d	-114.043	-289.093	177.0113	915.9748	11.5882	-845.957	-114.043
e	2.667244	4.458283	-7.70104	-46.8767	-1.11803	-5.8128	2.667244
f	1711.057	5668.321	343.5838	7471.166	1205.466	37493.08	1711.057
g	-165.543	-433.352	-64.7904	-749.815	-106.428	-4950.2	-165.543
h	17.51976	89.1329	10.81076	164.6374	18.74004	496.1266	17.51976
High Material 2							
	65	100	500	1	2	6	10
a	1843.573	223.3485	-1.29586	47.70061	14749.4	513.2768	1843.573
b	277.9022	-14.5625	23.07924	16.20172	1584.654	67.24861	277.9022
c	11.37842	1.930141	0.882404	0.19324	248.1536	2.587321	11.37842
d	-65.1741	-27.5274	9.160985	3.968816	-28.1043	-8.3154	-65.1741
e	1.734646	0.86876	-0.32501	-0.16908	-4.35444	0.145306	1.734646
f	908.2982	225.4601	2.932279	25.34628	5900.256	236.4326	908.2982
g	-38.9275	-0.99104	0.006023	-2.7008	-197.355	-14.5877	-38.9275
h	1.81932	0.563935	0.070625	0.10429	23.22802	0.657304	1.81932
Full Shield							
	65	100	500	1	2	6	10
a	119336.9	26432.57	1542.258	327.0399	12259.1	16923.17	119336.9
b	23300.25	5404.147	1452.036	189.5724	3179.716	3556.468	23300.25
c	1345.383	537.5094	50.60227	9.214141	297.751	131.4554	1345.383
d	-4953.39	464.8149	623.7905	48.51811	242.2157	-159.451	-4953.39
e	117.1209	-123.662	-24.882	-2.23423	-14.6292	-3.84993	117.1209
f	79667.77	53624.41	1370.412	246.1134	7413.46	11012.12	79667.77
g	-5439.38	-4366.62	-202.321	-28.1234	-592.46	-1093.08	-5439.38
h	318.611	399.0587	14.572	2.106384	50.40013	59.55944	318.611

Lead followed by polyethylene

Pb-Poly							
Low Material 2							
	65 log	100 log	500	1	2	6	10
a	50.05529	861.5893	42.00363	615.2121	1058.321	207.3674	307336.2
b	326.6194	2512.94	58.33274	561.5663	694.657	78.93512	97179.53
c	2.688163	138.7932	3.112091	32.01889	54.58237	11.06059	17812.4
d	91.11793	599.2609	-4.66809	-19.9323	5.404999	3.445909	9790.119
e	-1.38072	-5.07205	0.169022	0.624408	-0.15391	-0.0401	-312.157
f	709.9391	6251.088	54.68803	584.1483	877.7527	173.3889	263676.5
g	-22.4411	-281.976	-2.68477	-49.7614	-80.3694	-6.11783	-4294.25
h	2.435149	41.70354	0.235695	4.441924	8.676642	2.219526	4541.216
High Material 2							
	65	100	500	1	2	6	10
a	22704.4	409.3079	105.7723	300.5645	81.68136	306.8899	-842.605
b	64401.81	199.3052	184.1687	230.749	42.80864	705.4716	1264.568
c	135.056	0.94265	2.400254	2.111439	0.289	30.67193	23.44852
d	17464.76	42.57892	-9.48549	-3.03823	1.659766	153.078	488.2738
e	-252.387	-0.15498	0.340144	0.095277	-0.04755	-6.09412	-18.9455
f	148061.1	845.1034	130.7103	189.5782	44.25001	424.916	-254.683
g	-3568.28	-71.1617	-4.83267	-12.3078	-3.69534	5.927796	51.9979
h	145.5134	1.845665	0.172894	0.430605	0.125622	2.099043	-1.68417
Full Shield							
	65	100	500	1	2	6	10
a	55.39394	954.644	226.3646	27220.73	43987.49	1442.647	-232.231
b	247.207	823.1362	446.554	-3181.07	29564.33	1517.014	1699.166
c	0.873622	31.38376	9.209104	425.1951	618.4796	88.88563	23.39525
d	68.50854	91.16704	-27.7641	-1154.82	882.6216	297.9508	671.8188
e	-1.03896	4.114366	1.025083	51.69101	-24.1739	-12.2827	-27.6649
f	549.3023	2890.439	357.7025	6041.234	32467.33	1580.09	440.1484
g	-15.5665	-109.083	-15.6781	74.20974	-2945.68	-60.383	-58.311
h	0.904105	5.252979	0.746439	8.719921	144.2605	12.40775	2.860111

Aluminum followed by stainless steel

AI-SS							
Low Material 2							
	65	100 log	500	1	2	6	10
a	57831.75	2307.678	83994	16902.9	8248.466	7480.282	1413.199
b	10833.04	1654.919	31269.46	7126.574	3337.703	2307.324	376.5511
c	500.3472	411.6457	7039.09	1396.592	573.3852	302.8098	36.20536
d	4603.394	2879.583	-2023.9	-308.205	-65.5506	-3.62603	-0.90407
e	-206.959	-117.897	45.29526	7.292383	1.424522	-1.44673	-0.67731
f	44807.24	13968.75	48311.53	10575.96	5478.748	5596.136	1119.28
g	-7955.46	-2121.34	-3348.36	-820.524	-464.144	-556.01	-119.33
h	542.074	618.242	486.9909	122.0605	71.13311	69.28705	12.06017
High Material 2							
	65	100	500	1	2	6	10
a	5560.422	606.865	4624.8	7175.255	482.1351	11887.75	248.5404
b	524.94	119.8753	777.1543	1423.377	95.82053	2355.492	48.29069
c	54.47731	5.907491	133.7435	153.6703	7.139613	74.68965	1.026013
d	237.0475	202.0557	-69.3974	-72.0241	-2.34184	12.78519	-0.20155
e	-13.3773	-7.77476	1.571374	1.865149	0.075484	-0.57357	-0.03864
f	2898.673	1546.282	1360.196	2264.552	171.4404	5647.311	136.6157
g	-244.938	-124.924	-26.6184	-85.7554	-8.4082	-374.315	-9.4239
h	9.345196	8.209556	2.741265	6.325392	0.559231	17.32835	0.382485
Full Shield							
	65	100	500	1	2	6	10
a	1876.506	10539.61	811030.1	10193.43	28265.99	94.2675	3937.612
b	214.7301	5768.666	261848.2	-1263.86	9232.548	30.19639	1184.221
c	21.33888	911.8474	37321.87	363.3695	867.347	1.118615	23.30681
d	91.53803	10319.93	-12196.3	-475.863	-125.822	1.211542	58.14427
e	-4.95383	-433.806	151.3617	20.01832	2.821034	-0.05641	-3.77856
f	1205.916	47722.49	376076.5	2476.581	15070.1	62.60861	2886.486
g	-135.055	-4371.54	-19637.3	85.72764	-1029.99	-5.82296	-284.726
h	6.496763	962.7656	1617.477	9.069827	86.82618	0.335662	13.93758

Stainless steel followed by aluminum

SS-Al							
Low Material 2							
	65	100 log	500	1	2	6	10
a	64103.13	484.656	34.48958	41.11441	14193.25	122.4613	878.585
b	29802.22	384.5455	21.07777	21.18739	6142.869	38.9008	223.379
c	1079.414	21.95766	3.412758	3.64095	1064.961	7.042162	43.33178
d	-1483.23	-19.1962	-1.10714	-0.80341	-89.5598	0.74898	7.795804
e	-8.74219	0.347372	0.03192	0.021954	2.663736	-0.01385	-0.31644
f	51572.14	414.6619	23.14473	26.99868	9503.441	93.10222	701.4852
g	-2368.45	-26.2026	-1.96535	-2.29985	-801.377	-6.24854	-39.0555
h	186.4857	2.142788	0.212461	0.300719	125.9203	1.321002	9.574564
High Material 2							
	65	100	500	1	2	6	10
a	16077.53	9144.96	27202.61	5294.627	3635.742	102.6158	705.1788
b	7643.489	7480.524	14060.43	1808.543	861.5265	18.87848	185.8523
c	71.19669	109.5523	497.6131	82.144	58.2397	2.573015	18.22236
d	-221.738	-206.08	-161.131	-8.78351	-3.59676	-0.0117	22.35832
e	-4.63596	2.696299	2.168688	-0.00456	0.20655	-0.00656	-1.05038
f	11605.43	6415.096	10431.46	1842.63	1323.936	50.0726	424.6635
g	-456.297	-334.382	-780.747	-124.714	-69.5738	-0.63407	-5.25476
h	14.44629	11.14256	30.67386	5.685545	4.435286	0.216014	1.731426
Full Shield							
	65	100	500	1	2	6	10
a	173232.6	53.74397	25.00251	29001.72	1314.299	1518.138	2.42E+06
b	86246.93	48.1264	14.01738	11665.79	441.2871	488.5859	846235
c	1276.821	1.098347	1.056534	1119.278	46.37132	51.44652	73058.54
d	-3162.01	-1.77655	-0.52821	-405.501	-7.03793	27.58279	119249.4
e	-38.3107	0.033807	0.017502	13.72782	0.284345	-1.02969	-5107.59
f	138016.8	45.77421	13.39309	14498.72	698.7485	1046.416	1.89E+06
g	-6012.03	-2.67016	-0.98344	-981.741	-45.0535	-57.0714	-103036
h	255.8745	0.116904	0.054158	69.41385	4.103865	7.255705	12308.17

Stainless steel followed by lead

SS-Pb							
Low Material 2							
	65	100	500	1	2	6	10
a	3506.78	4996.287	14429.4	40359.16	3317.237	14607.88	23555
b	464.7246	1062.093	10738.55	16806.75	857.0648	2617.586	3389.715
c	27.92993	127.9116	876.7613	3017.063	193.0399	444.0231	777.3818
d	135.2561	-665.304	4511.396	3411.076	21.37297	-335.748	-1338.71
e	-4.87429	9.494033	-199.016	-175.755	-2.13326	1.656772	35.3248
f	2703.419	15091.85	13545.64	31173.3	2302.782	11201.74	18173.8
g	-193.95	-569.848	-2393.48	-3151.8	-198.669	-1225.15	-1459.74
h	17.22278	113.0814	315.1057	650.8426	35.32674	121.2181	140.947
High Material 2							
	65	100	500	1	2	6	10
a	283.7909	25.77924	52.67672	669.5314	315.0637	1554.433	322.4094
b	13.47512	1.52638	65.08942	199.1953	43.43121	171.2439	49.64944
c	1.463804	0.124428	3.033531	2.331208	5.506256	13.18436	3.985213
d	0.14118	-3.84391	24.85294	46.56806	1.341058	-32.7825	-14.4779
e	-0.08522	0.112293	-0.98466	-2.00895	-0.17375	0.742109	0.438888
f	182.2176	50.71137	38.74521	345.6087	131.1843	763.4326	187.5527
g	-6.00301	-0.72579	-2.41277	-36.5164	-5.04191	-43.7607	-8.20811
h	0.413819	0.077977	0.290238	1.366745	0.504553	1.964672	0.345562
Full Shield							
	65	100	500	1	2	6	10
a	1377.539	1417.826	14631.64	2458.413	3227.841	6731.125	189121.8
b	217.3251	324.1379	8135.526	1243.362	852.5234	1290.034	29516.91
c	-3.76377	15.5215	345.6379	64.94765	85.0493	76.73501	3295.972
d	73.62225	-90.6233	3262.25	302.5859	66.37102	-94.9277	-10178.5
e	-2.32615	-2.36499	-137.594	-14.0985	-4.04802	-0.25661	314.3946
f	1059.8	3920.379	11404.25	1777.52	1968.032	4569.814	133060.2
g	-84.8767	-130.447	-1502.9	-197.16	-153.243	-413.392	-7704.03
h	1.630818	13.52644	98.05652	14.31662	13.20454	21.60691	409.4501

Lead followed by stainless steel

Pb-SS							
Low Material 2							
	65	100	500	1	2	6	10
a	8249.779	-25.7461	135500.4	2944.711	18771.96	420.5078	15588.69
b	1481.667	40.08514	88125.01	1879.468	9895.813	126.9914	3492.291
c	30.10641	2.076269	3866.879	114.5182	897.4479	18.57892	782.1262
d	375.5455	124.7034	-3663.96	-40.1568	-36.1221	-4.24526	-122.424
e	-13.4522	-6.32388	64.32511	0.59751	-0.71393	0.015113	-9.86786
f	7297.706	-19.9583	114476.3	2384.64	14578.39	339.1044	12218.87
g	-469.047	1.515139	-8041.92	-212.548	-1263.94	-16.4055	-437.2
h	28.16817	1.75514	656.5734	19.42013	142.0096	2.932635	104.3927
High Material 2							
	65	100	500	1	2	6	10
a	937.5829	-162.685	450.4791	2612.351	1329.127	17648.67	56.58977
b	137.6707	49.46068	278.1809	1360.79	551.8624	4622.184	32.46215
c	0.078397	3.696322	2.553085	12.39907	7.06197	466.4318	3.085344
d	29.08029	126.3175	-6.15041	-1.05637	15.35804	-58.5876	4.468151
e	-0.94434	-3.65927	0.074333	-0.27116	-0.51003	-4.52567	-0.28656
f	768.1741	-656.894	302.7775	1435.788	681.4129	10742.14	43.37743
g	-40.338	128.1882	-16.4289	-98.5515	-51.2886	-31.7496	2.021009
h	0.939974	-5.62171	0.546599	3.408679	1.87074	18.91656	-0.10905
Full Shield							
	65	100	500	1	2	6	10
a	11804.36	-461.383	282269.6	2313.012	1226.439	2936.076	11657.82
b	2454.98	519.8081	200106.6	1546.537	646.9085	991.2472	5776.471
c	-17.0502	26.21951	2978.585	25.56368	18.48644	89.79433	451.2114
d	731.0419	1562.629	-5102.12	-1.18546	12.35109	17.20069	856.7513
e	-24.779	-66.4241	63.9824	-0.47237	-0.4344	-2.05197	-53.1616
f	10473.92	-1282.67	231211.4	1702.196	841.5942	2255.388	10296.49
g	-704.021	345.3192	-14804.9	-140.586	-70.4168	-85.4781	-410.382
h	15.00291	-17.4372	650.1162	6.474724	3.674914	8.764558	19.74245

Polyethylene followed by stainless steel

Poly-SS							
Low Material 2							
	65	100	500	1	2	6	10
a	9219.498	474.4231	73.45185	59585.96	10411.34	13852.24	19540.4
b	4118.966	405.2344	27.09588	25058.61	4238.201	4507.601	5659.87
c	292.9279	23.21256	6.135806	4919.367	712.0329	487.789	386.099
d	2440.549	147.3611	-1.7696	-1087.89	-78.1011	59.57827	107.3443
e	-107.933	-7.57977	0.038817	25.56002	1.627131	-5.00223	-13.6957
f	7211.856	427.7668	42.1319	37256.36	6918.871	10329.91	15450.16
g	-1908.14	-101.624	-2.83333	-2862.52	-593.496	-1175.97	-1975.35
h	166.0208	9.285423	0.427285	431.2684	90.12441	135.1502	189.5814
High Material 2							
	65	100	500	1	2	6	10
a	-1342.98	-23.6079	1386.746	11328.74	5537.643	1870.616	401.4432
b	1550.122	64.32912	220.4493	2203.625	1110.911	411.006	87.57744
c	101.9446	3.37091	40.14059	242.5954	76.45784	7.218105	0.931052
d	663.2268	19.87727	-21.118	-115.896	-24.4898	8.802974	0.99663
e	-24.9905	-0.93074	0.458066	2.973322	0.805896	-0.30695	-0.11049
f	-552.412	1.396385	403.3472	3562.979	1968.979	882.7514	215.4855
g	121.5267	1.186896	-6.68244	-131.637	-100.267	-64.1559	-15.5957
h	-5.20907	-0.00327	0.83153	10.04684	6.43824	2.718382	0.618645
Full Shield							
	65	100	500	1	2	6	10
a	16599.61	580.4622	99825.78	77590.41	17904.51	16890.56	8500.754
b	5415.804	317.45	32864.89	25809.33	5947.234	5954.55	2658.367
c	387.6431	12.78817	4618.083	3121.812	523.3663	123.9663	30.69845
d	3453.736	109.8372	-1396.58	-961.088	-62.7963	337.3343	137.6202
e	-170.782	-5.62555	10.52109	19.99272	1.195222	-14.5529	-8.42109
f	9572.038	385.1101	46645.88	37923.09	9568.669	11247.3	6102.856
g	-1623.02	-61.7245	-2412.52	-2230.75	-673.654	-1175.71	-645.272
h	80.00911	3.136803	206.2469	193.4155	55.31797	62.33785	32.00025

Stainless steel followed by polyethylene

SS-Poly							
Low Material 2							
	65 (log)	100 (log)	500 (log)	1	2	6	10
a	4507.207	899.9335	2898.407	87.91729	4645.088	657.1526	14362.96
b	21670.51	2729.846	2572.83	66.84032	2327.412	231.003	4417.673
c	221.8594	55.60148	190.4295	9.434377	371.5786	43.34794	846.2785
d	6015.438	631.6399	1005.77	-2.12416	-11.4235	11.59524	417.6663
e	-90.3111	-6.31602	-8.24362	0.066821	0.451072	-0.16147	-8.0482
f	47827.53	6914.496	11605.28	69.01021	3243.074	508.7526	11936.46
g	-1872.18	-408.474	-1375.08	-6.40831	-287.146	-29.5578	-500.047
h	210.3204	51.73085	216.6955	0.739881	43.62391	8.533817	212.6197
High Material 2							
	65 (log)	100 (log)	500	1	2	6	10
a	12978.66	12155.49	415.3634	242.5925	426.3318	224.611	3571.975
b	28219.18	14458.17	142.5752	145.2104	142.3381	95.52511	3080.872
c	67.58508	62.3983	1.179657	2.468293	5.026847	8.024342	66.84387
d	7569.806	3096.288	50.21512	1.636182	4.158251	12.95072	871.5653
e	-107.018	-23.2217	-0.08012	-0.06889	-0.11713	-0.46649	-29.2948
f	66329.82	40281.22	792.2188	101.0984	166.8929	132.4544	3066.319
g	-1837.43	-1454.71	-51.7197	-9.2291	-12.1432	-1.94465	-215.289
h	74.56843	63.24544	2.243895	0.352092	0.582078	0.798621	13.53576
Full Shield							
	65 (log)	100 (log)	500	1	2	6	10
a	10705.61	7738.586	6368.679	9118.216	2118.14	1431.135	5184.908
b	36166.37	15692.45	4479.163	6395.959	806.5251	701.7706	4636.31
c	151.3745	122.0662	75.65897	350.6454	77.65784	65.34118	238.2486
d	9985.857	3655.006	1986.449	-92.864	-7.82469	92.28786	1267.145
e	-151.144	-40.3081	-25.1568	4.089105	0.545758	-3.24622	-46.2039
f	81736.38	40846.34	19677.26	5662.886	1157.389	1102.801	5323.095
g	-2772.5	-1974.46	-1971.92	-486.265	-78.1679	-59.0103	-348.6
h	163.2522	126.7855	128.1145	27.5254	6.865483	9.933484	49.69008

Appendix 6: Dose Fit Percent Differences

The following tables present the fractional differences between the analytical fit and the dose buildup data at each thickness point. The tables labeled “Low” are for 1-10 mfp of the first material followed by 1-5 mfp of the second material. “High” is for 1-10 mfp of the first material followed by 6-10 mfp of the second material. “Full” is for 1-10 mfp of the first material followed by 1-10 mfp of the second material.

The first material thicknesses increase along the rows, the second material thicknesses increase along columns. For example, for a full shield fit, column 2 shows fractional differences for shields with 2 mfp of material 1 followed by 1-10 mfp of material 2.

Aluminum followed by lead
65 keV Al-Pb Dose (Fractional Difference)

Full	1	2	3	4	5	6	7	8	9	10
1	9.99E-02	9.65E-02	7.40E-02	5.15E-02	3.32E-02	2.02E-02	1.28E-02	1.13E-02	1.58E-02	2.56E-02
2	3.09E-03	3.05E-02	2.46E-02	1.20E-02	4.40E-04	-7.51E-03	-1.08E-02	-8.82E-03	-1.43E-03	1.19E-02
3	-4.19E-02	-1.33E-03	4.65E-04	-7.28E-03	-1.55E-02	-2.09E-02	-2.20E-02	-1.78E-02	-8.02E-03	7.02E-03
4	-5.56E-02	-1.01E-02	-5.64E-03	-1.18E-02	-1.91E-02	-2.36E-02	-2.39E-02	-1.87E-02	-7.75E-03	8.70E-03
5	-5.03E-02	-4.18E-03	4.91E-06	-6.77E-03	-1.45E-02	-1.95E-02	-1.98E-02	-1.44E-02	-3.01E-03	1.43E-02
6	-3.51E-02	9.40E-03	1.16E-02	3.01E-03	-6.20E-03	-1.22E-02	-1.32E-02	-8.18E-03	2.67E-03	2.07E-02
7	-1.83E-02	2.31E-02	2.22E-02	1.10E-02	-3.07E-04	-3.94E-03	-6.32E-03	-2.52E-03	7.86E-03	2.54E-02
8	-6.14E-03	3.26E-02	2.94E-02	1.63E-02	3.40E-03	-1.41E-03	-4.84E-03	-1.83E-03	7.88E-03	2.49E-02
9	-5.38E-03	3.19E-02	2.75E-02	1.33E-02	-5.65E-04	-6.22E-03	-1.05E-02	-8.39E-03	6.73E-04	1.70E-02
10	-2.01E-02	1.74E-02	1.34E-02	-5.32E-04	-1.44E-02	-2.04E-02	-2.50E-02	-2.34E-02	-1.52E-02	1.48E-04

Low	1	2	3	4	5	6	7	8	9	10
1	8.94E-03	2.50E-02	1.87E-02	8.61E-03	-5.17E-04	-6.99E-03	-1.01E-02	-9.51E-03	-4.61E-03	3.74E-03
2	-3.09E-02	5.98E-03	8.77E-03	3.16E-03	-3.24E-03	-7.69E-03	-9.05E-03	-6.49E-03	2.78E-06	1.09E-02
3	-3.34E-02	8.04E-03	1.18E-02	6.06E-03	-6.05E-04	-5.14E-03	-6.26E-03	-3.01E-03	4.79E-03	1.65E-02
4	-1.94E-02	1.81E-02	1.81E-02	9.47E-03	7.20E-04	-5.19E-03	-7.08E-03	-4.06E-03	3.85E-03	1.61E-02
5	-7.55E-03	2.24E-02	1.71E-02	4.75E-03	-6.56E-03	-1.42E-02	-1.72E-02	-1.48E-02	-7.30E-03	4.99E-03

High	1	2	3	4	5	6	7	8	9	10
6	-2.15E-02	1.31E-02	1.08E-02	1.05E-03	-7.43E-03	-1.16E-02	-1.00E-02	-2.00E-03	1.23E-02	3.43E-02
7	-1.88E-02	1.59E-02	1.24E-02	6.94E-04	-1.00E-02	-1.25E-02	-1.33E-02	-7.91E-03	4.16E-03	2.34E-02
8	-1.50E-02	2.10E-02	1.73E-02	4.52E-03	-7.67E-03	-1.17E-02	-1.44E-02	-1.09E-02	-8.86E-04	1.61E-02
9	-1.37E-02	2.44E-02	2.12E-02	8.00E-03	-5.17E-03	-1.05E-02	-1.47E-02	-1.29E-02	-4.67E-03	1.04E-02
10	-1.65E-02	2.44E-02	2.24E-02	9.44E-03	-4.18E-03	-1.04E-02	-1.57E-02	-1.52E-02	-8.63E-03	4.60E-03

100 keV Al-Pb Dose (Fractional Difference)

Full	1	2	3	4	5	6	7	8	9	10
1	2.57E-01	2.68E-01	2.72E-01	2.60E-01	2.31E-01	1.88E-01	1.34E-01	7.73E-02	2.52E-02	-1.50E-02
2	4.95E-03	4.99E-02	7.31E-02	7.40E-02	5.62E-02	2.43E-02	-1.43E-02	-5.17E-02	-7.99E-02	-9.10E-02
3	-1.17E-01	-5.93E-02	-2.69E-02	-1.86E-02	-2.86E-02	-5.03E-02	-7.53E-02	-9.48E-02	-9.98E-02	-8.09E-02
4	-1.69E-01	-1.03E-01	-6.43E-02	-5.00E-02	-5.32E-02	-6.60E-02	-7.86E-02	-8.13E-02	-6.36E-02	-1.26E-02
5	-1.77E-01	-1.03E-01	-5.86E-02	-3.94E-02	-4.12E-02	-4.70E-02	-4.96E-02	-3.81E-02	1.86E-04	8.20E-02
6	-1.54E-01	-7.45E-02	-2.71E-02	-6.66E-03	-7.54E-03	-1.11E-02	-9.26E-03	1.01E-02	6.10E-02	1.63E-01
7	-1.11E-01	-2.83E-02	1.82E-02	3.52E-02	2.97E-02	2.19E-02	2.03E-02	3.76E-02	8.78E-02	1.91E-01
8	-5.75E-02	2.42E-02	6.45E-02	7.17E-02	5.47E-02	3.48E-02	2.08E-02	2.46E-02	5.87E-02	1.40E-01
9	-3.59E-03	7.15E-02	9.92E-02	9.01E-02	5.50E-02	1.63E-02	-1.75E-02	-3.58E-02	-2.91E-02	1.41E-02
10	4.11E-02	1.03E-01	1.13E-01	8.20E-02	2.46E-02	-3.65E-02	-9.31E-02	-1.36E-01	-1.60E-01	-1.57E-01

Low	1	2	3	4	5	6	7	8	9	10
1	1.11E-01	9.66E-02	8.64E-02	7.36E-02	5.71E-02	3.66E-02	1.42E-02	-7.22E-03	-2.45E-02	-3.55E-02
2	-6.14E-02	-3.76E-02	-2.43E-02	-2.06E-02	-2.33E-02	-2.93E-02	-3.39E-02	-3.23E-02	-1.99E-02	7.09E-03
3	-1.04E-01	-6.24E-02	-3.76E-02	-2.66E-02	-2.37E-02	-2.35E-02	-1.99E-02	-6.50E-03	2.24E-02	7.18E-02
4	-7.48E-02	-2.26E-02	6.01E-03	1.58E-02	1.39E-02	7.47E-03	3.66E-03	8.96E-03	2.86E-02	6.67E-02
5	-4.96E-03	5.06E-02	7.36E-02	7.07E-02	4.64E-02	1.76E-02	-1.20E-02	-3.65E-02	-5.21E-02	-5.70E-02

High	1	2	3	4	5	6	7	8	9	10
6	-8.40E-02	-6.94E-02	-7.60E-02	-9.41E-02	-1.17E-01	-1.30E-01	-1.33E-01	-1.25E-01	-1.13E-01	-1.13E-01
7	-1.24E-01	-1.02E-01	-1.02E-01	-1.15E-01	-1.31E-01	-1.39E-01	-1.36E-01	-1.23E-01	-1.06E-01	-1.03E-01
8	-1.42E-01	-1.14E-01	-1.10E-01	-1.17E-01	-1.30E-01	-1.34E-01	-1.29E-01	-1.14E-01	-9.92E-02	-1.00E-01
9	-1.46E-01	-1.12E-01	-1.03E-01	-1.07E-01	-1.19E-01	-1.22E-01	-1.19E-01	-1.09E-01	-1.01E-01	-1.13E-01
10	-1.38E-01	-9.94E-02	-8.71E-02	-9.05E-02	-1.03E-01	-1.09E-01	-1.11E-01	-1.11E-01	-1.17E-01	-1.45E-01

500 keV Al-Pb Dose (Fractional Difference)

Full	1	2	3	4	5	6	7	8	9	10
1	4.71E-02	7.51E-02	6.77E-02	5.09E-02	3.30E-02	1.71E-02	4.67E-03	-3.73E-03	-7.64E-03	-6.67E-03
2	-3.10E-02	1.99E-02	2.74E-02	2.13E-02	1.12E-02	1.56E-03	-5.84E-03	-9.93E-03	-1.00E-02	-5.61E-03
3	-5.66E-02	-4.00E-03	7.31E-03	5.39E-03	-5.61E-04	-6.78E-03	-1.07E-02	-1.20E-02	-9.35E-03	-2.28E-03
4	-5.25E-02	-8.26E-03	7.97E-04	-7.98E-04	-5.39E-03	-9.83E-03	-1.19E-02	-1.12E-02	-6.56E-03	2.49E-03
5	-3.31E-02	-1.34E-03	2.51E-03	-9.07E-04	-5.71E-03	-9.56E-03	-1.08E-02	-8.73E-03	-2.75E-03	7.74E-03
6	-9.63E-03	9.85E-03	7.84E-03	1.85E-03	-3.88E-03	-7.77E-03	-8.40E-03	-5.79E-03	1.07E-03	1.26E-02
7	8.59E-03	1.95E-02	1.29E-02	4.64E-03	-2.04E-03	-6.17E-03	-6.77E-03	-3.55E-03	3.92E-03	1.62E-02
8	1.48E-02	2.31E-02	1.45E-02	5.13E-03	-1.99E-03	-5.97E-03	-6.53E-03	-2.96E-03	4.96E-03	1.77E-02
9	5.46E-03	1.80E-02	1.04E-02	1.64E-03	-5.06E-03	-8.64E-03	-8.61E-03	-4.79E-03	3.54E-03	1.67E-02
10	-2.00E-02	2.76E-03	-4.37E-04	-6.96E-03	-1.22E-02	-1.50E-02	-1.42E-02	-9.63E-03	-8.48E-04	1.26E-02

Low	1	2	3	4	5	6	7	8	9	10
1	-1.39E-02	2.82E-02	2.92E-02	1.90E-02	7.09E-03	-2.95E-03	-9.43E-03	-1.15E-02	-8.38E-03	4.78E-04
2	-3.70E-02	8.08E-03	1.36E-02	7.91E-03	-2.08E-04	-6.76E-03	-1.02E-02	-9.32E-03	-3.49E-03	8.07E-03
3	-2.14E-02	1.17E-02	1.32E-02	6.56E-03	-9.84E-04	-6.74E-03	-8.70E-03	-6.65E-03	6.40E-04	1.37E-02
4	-4.80E-03	1.85E-02	1.53E-02	6.68E-03	-1.52E-03	-7.26E-03	-8.89E-03	-6.33E-03	1.54E-03	1.52E-02
5	-8.99E-03	1.47E-02	1.08E-02	1.91E-03	-6.34E-03	-1.20E-02	-1.36E-02	-1.07E-02	-2.71E-03	1.10E-02

High	1	2	3	4	5	6	7	8	9	10
6	-1.56E-02	2.16E-03	7.09E-03	7.17E-03	5.47E-03	3.63E-03	3.37E-03	4.81E-03	9.09E-03	1.66E-02
7	-4.68E-03	3.94E-03	3.27E-03	4.69E-04	-2.58E-03	-4.92E-03	-5.39E-03	-3.58E-03	1.02E-03	8.86E-03
8	1.22E-03	7.82E-03	3.89E-03	-1.14E-03	-5.51E-03	-8.40E-03	-9.39E-03	-7.72E-03	-3.14E-03	4.73E-03
9	6.85E-04	1.12E-02	6.49E-03	2.68E-04	-5.06E-03	-8.61E-03	-9.87E-03	-8.66E-03	-4.27E-03	3.48E-03
10	-6.48E-03	1.24E-02	9.29E-03	3.03E-03	-2.67E-03	-6.80E-03	-8.42E-03	-7.31E-03	-3.16E-03	4.36E-03

1 MeV Al-Pb Dose (Fractional Difference)

Full	1	2	3	4	5	6	7	8	9	10
1	7.92E-02	8.63E-02	7.13E-02	5.13E-02	3.21E-02	1.60E-02	4.25E-03	-2.73E-03	-4.37E-03	-2.88E-04
2	-2.08E-02	1.92E-02	2.34E-02	1.61E-02	5.95E-03	-3.16E-03	-9.35E-03	-1.16E-02	-9.08E-03	-1.12E-03
3	-5.79E-02	-8.76E-03	1.94E-03	-2.68E-04	-6.19E-03	-1.17E-02	-1.47E-02	-1.41E-02	-8.75E-03	1.96E-03
4	-6.06E-02	-1.30E-02	-2.49E-03	-4.04E-03	-8.85E-03	-1.30E-02	-1.46E-02	-1.23E-02	-5.31E-03	7.24E-03
5	-4.57E-02	-3.91E-03	2.97E-03	-3.76E-04	-5.94E-03	-1.02E-02	-1.15E-02	-8.53E-03	-6.46E-04	1.30E-02
6	-2.50E-02	1.00E-02	1.23E-02	6.20E-03	-9.69E-04	-6.07E-03	-7.67E-03	-4.72E-03	3.44E-03	1.75E-02
7	-7.54E-03	2.24E-02	2.07E-02	1.19E-02	3.10E-03	-3.05E-03	-5.27E-03	-2.64E-03	5.39E-03	1.95E-02
8	4.42E-04	2.83E-02	2.44E-02	1.39E-02	3.92E-03	-3.05E-03	-5.87E-03	-3.68E-03	4.02E-03	1.79E-02
9	-4.33E-03	2.50E-02	2.11E-02	1.03E-02	-5.85E-05	-7.40E-03	-1.05E-02	-8.77E-03	-1.49E-03	1.18E-02
10	-2.24E-02	1.14E-02	9.73E-03	1.25E-04	-9.68E-03	-1.68E-02	-2.00E-02	-1.84E-02	-1.15E-02	1.18E-03

Low	1	2	3	4	5	6	7	8	9	10
1	2.06E-02	2.93E-02	2.29E-02	1.27E-02	2.73E-03	-4.93E-03	-9.19E-03	-9.43E-03	-4.87E-03	5.03E-03
2	-3.36E-02	-1.59E-03	3.61E-03	3.56E-04	-4.90E-03	-9.07E-03	-1.06E-02	-8.41E-03	-1.69E-03	1.03E-02
3	-3.31E-02	3.13E-03	8.94E-03	5.44E-03	-2.10E-04	-4.78E-03	-6.61E-03	-4.73E-03	1.80E-03	1.36E-02
4	-2.24E-02	1.48E-02	1.89E-02	1.32E-02	5.44E-03	-1.07E-03	-4.67E-03	-4.46E-03	4.33E-04	1.06E-02
5	-2.33E-02	1.70E-02	2.08E-02	1.38E-02	4.34E-03	-4.06E-03	-9.71E-03	-1.15E-02	-8.85E-03	-1.15E-03

High	1	2	3	4	5	6	7	8	9	10
6	-2.64E-02	1.46E-02	1.96E-02	1.40E-02	5.84E-03	-1.36E-03	-6.02E-03	-7.07E-03	-3.92E-03	3.99E-03
7	-2.62E-02	1.16E-02	1.53E-02	9.67E-03	2.31E-03	-3.72E-03	-6.97E-03	-6.43E-03	-1.56E-03	8.23E-03
8	-1.92E-02	1.29E-02	1.37E-02	7.10E-03	-2.75E-04	-5.71E-03	-8.01E-03	-6.28E-03	-6.99E-06	1.14E-02
9	-9.56E-03	1.55E-02	1.27E-02	4.43E-03	-3.36E-03	-8.55E-03	-1.01E-02	-7.54E-03	-1.29E-04	1.26E-02
10	-1.56E-03	1.63E-02	9.83E-03	-2.63E-05	-8.33E-03	-1.34E-02	-1.45E-02	-1.11E-02	-2.74E-03	1.10E-02

2 MeV Al-Pb Dose (Fractional Difference)

Full	1	2	3	4	5	6	7	8	9	10
1	1.46E-01	1.13E-01	8.49E-02	6.18E-02	4.26E-02	2.71E-02	1.51E-02	6.65E-03	1.78E-03	4.98E-04
2	1.46E-02	2.12E-02	1.72E-02	1.02E-02	2.78E-03	-3.54E-03	-8.03E-03	-1.02E-02	-9.59E-03	-5.92E-03
3	-4.03E-02	-1.83E-02	-1.24E-02	-1.22E-02	-1.40E-02	-1.56E-02	-1.61E-02	-1.47E-02	-1.08E-02	-3.94E-03
4	-5.51E-02	-2.78E-02	-1.87E-02	-1.61E-02	-1.59E-02	-1.57E-02	-1.45E-02	-1.14E-02	-5.81E-03	2.74E-03
5	-4.88E-02	-2.07E-02	-1.19E-02	-9.65E-03	-9.60E-03	-9.46E-03	-8.07E-03	-4.68E-03	1.39E-03	1.06E-02
6	-3.37E-02	-6.74E-03	2.53E-04	7.74E-04	-5.69E-04	-1.51E-03	-9.46E-04	1.85E-03	7.51E-03	1.64E-02
7	-1.79E-02	7.28E-03	1.19E-02	1.02E-02	6.97E-03	4.41E-03	3.61E-03	5.24E-03	9.89E-03	1.79E-02
8	-7.05E-03	1.66E-02	1.90E-02	1.52E-02	9.97E-03	5.65E-03	3.29E-03	3.47E-03	6.75E-03	1.34E-02
9	-4.06E-03	1.85E-02	1.92E-02	1.36E-02	6.72E-03	7.92E-04	-3.13E-03	-4.46E-03	-2.70E-03	2.39E-03
10	-1.00E-02	1.21E-02	1.17E-02	4.86E-03	-3.35E-03	-1.06E-02	-1.59E-02	-1.88E-02	-1.83E-02	-1.50E-02

Low	1	2	3	4	5	6	7	8	9	10
1	5.11E-02	3.57E-02	2.39E-02	1.46E-02	7.20E-03	1.50E-03	-2.45E-03	-4.69E-03	-5.02E-03	-3.40E-03
2	-2.43E-02	-1.16E-02	-7.81E-03	-6.92E-03	-6.97E-03	-6.92E-03	-6.20E-03	-4.43E-03	-1.20E-03	3.66E-03
3	-3.25E-02	-1.27E-02	-6.07E-03	-3.78E-03	-3.07E-03	-2.48E-03	-1.30E-03	8.86E-04	4.55E-03	9.86E-03
4	-1.79E-02	1.76E-03	6.18E-03	5.86E-03	4.08E-03	2.40E-03	1.55E-03	1.93E-03	3.94E-03	7.74E-03
5	-4.49E-03	1.31E-02	1.39E-02	9.72E-03	4.30E-03	-7.26E-04	-4.68E-03	-7.19E-03	-7.90E-03	-6.74E-03

High	1	2	3	4	5	6	7	8	9	10
6	-4.48E-03	1.11E-02	9.81E-03	4.52E-03	-8.89E-04	-4.72E-03	-6.29E-03	-5.19E-03	-1.05E-03	6.32E-03
7	-1.32E-02	6.41E-03	7.37E-03	3.37E-03	-1.29E-03	-4.74E-03	-6.16E-03	-5.10E-03	-1.11E-03	5.98E-03
8	-1.65E-02	6.14E-03	8.51E-03	5.14E-03	6.54E-04	-2.92E-03	-4.66E-03	-4.07E-03	-6.80E-04	5.69E-03
9	-1.77E-02	7.20E-03	1.05E-02	7.45E-03	2.82E-03	-1.15E-03	-3.47E-03	-3.62E-03	-1.11E-03	4.25E-03
10	-1.93E-02	7.50E-03	1.16E-02	8.61E-03	3.73E-03	-7.55E-04	-3.79E-03	-4.97E-03	-3.20E-03	8.25E-04

6 MeV Al-Pb Dose (Fractional Difference)

Full	1	2	3	4	5	6	7	8	9	10
1	1.32E-01	1.37E-01	1.36E-01	1.30E-01	1.19E-01	1.04E-01	8.77E-02	6.93E-02	4.99E-02	3.00E-02
2	8.31E-03	2.71E-02	3.65E-02	3.88E-02	3.60E-02	2.93E-02	1.98E-02	8.48E-03	-4.06E-03	-1.72E-02
3	-4.79E-02	-2.52E-02	-1.21E-02	-5.79E-03	-4.52E-03	-6.89E-03	-1.18E-02	-1.85E-02	-2.61E-02	-3.42E-02
4	-6.69E-02	-4.41E-02	-3.01E-02	-2.23E-02	-1.89E-02	-1.87E-02	-2.06E-02	-2.38E-02	-2.77E-02	-3.15E-02
5	-6.35E-02	-4.25E-02	-2.93E-02	-2.15E-02	-1.73E-02	-1.56E-02	-1.55E-02	-1.62E-02	-1.69E-02	-1.71E-02
6	-4.69E-02	-2.92E-02	-1.81E-02	-1.14E-02	-7.41E-03	-5.24E-03	-3.98E-03	-2.93E-03	-8.71E-04	2.00E-03
7	-2.43E-02	-1.11E-02	-3.37E-03	1.14E-03	4.16E-03	5.78E-03	7.20E-03	9.15E-03	1.28E-02	1.79E-02
8	-2.28E-03	5.40E-03	9.28E-03	1.06E-02	1.09E-02	1.10E-02	1.20E-02	1.37E-02	1.73E-02	2.34E-02
9	1.43E-02	1.56E-02	1.43E-02	1.15E-02	8.45E-03	5.92E-03	4.46E-03	5.09E-03	7.55E-03	1.30E-02
10	2.13E-02	1.56E-02	8.46E-03	7.15E-04	-6.46E-03	-1.26E-02	-1.72E-02	-1.94E-02	-1.95E-02	-1.65E-02

Low	1	2	3	4	5	6	7	8	9	10
1	2.82E-02	3.32E-02	3.55E-02	3.44E-02	3.05E-02	2.43E-02	1.66E-02	7.77E-03	-1.64E-03	-1.12E-02
2	-3.42E-02	-1.99E-02	-1.07E-02	-5.52E-03	-3.36E-03	-3.34E-03	-4.76E-03	-6.97E-03	-9.52E-03	-1.19E-02
3	-3.57E-02	-2.27E-02	-1.42E-02	-8.75E-03	-5.41E-03	-3.41E-03	-2.11E-03	-9.01E-04	6.88E-04	3.22E-03
4	-1.11E-02	-4.72E-03	-1.17E-03	6.96E-04	1.69E-03	2.40E-03	3.33E-03	5.02E-03	7.89E-03	1.25E-02
5	1.72E-02	1.39E-02	9.46E-03	4.86E-03	6.32E-04	-2.87E-03	-5.31E-03	-6.27E-03	-5.42E-03	-2.24E-03

High	1	2	3	4	5	6	7	8	9	10
6	-1.37E-03	2.07E-03	4.07E-03	5.27E-03	5.78E-03	5.55E-03	4.49E-03	2.41E-03	-2.59E-04	-4.56E-03
7	-7.53E-03	-4.94E-03	-3.38E-03	-2.11E-03	-6.57E-04	3.62E-05	2.72E-04	-8.72E-05	-7.34E-04	-2.73E-03
8	-5.58E-03	-4.58E-03	-3.69E-03	-3.02E-03	-2.13E-03	-1.17E-03	1.67E-04	8.24E-04	1.09E-03	7.45E-04
9	1.43E-03	1.39E-04	-7.72E-04	-1.41E-03	-1.39E-03	-8.79E-04	-6.54E-05	1.28E-03	2.11E-03	2.63E-03
10	1.05E-02	6.26E-03	2.91E-03	2.73E-04	-1.27E-03	-1.97E-03	-2.05E-03	-1.28E-03	-7.68E-04	-2.93E-04

10 MeV Al-Pb Dose (Fractional Difference)

Full	1	2	3	4	5	6	7	8	9	10
1	9.16E-02	1.16E-01	1.38E-01	1.53E-01	1.59E-01	1.49E-01	1.36E-01	1.16E-01	8.71E-02	5.06E-02
2	-2.00E-02	6.51E-03	2.94E-02	4.54E-02	5.39E-02	5.48E-02	4.05E-02	2.63E-02	5.20E-03	-2.29E-02
3	-7.02E-02	-4.60E-02	-2.48E-02	-9.17E-03	3.14E-04	3.79E-03	1.28E-03	-7.07E-03	-2.93E-02	-5.00E-02
4	-8.53E-02	-6.52E-02	-4.67E-02	-3.23E-02	-2.25E-02	-1.72E-02	-1.63E-02	-1.99E-02	-2.82E-02	-4.14E-02
5	-7.82E-02	-6.33E-02	-4.83E-02	-3.59E-02	-2.65E-02	-2.00E-02	-1.65E-02	-1.59E-02	-1.84E-02	-2.46E-02
6	-5.69E-02	-4.79E-02	-3.76E-02	-2.79E-02	-1.97E-02	-1.30E-02	-8.07E-03	-4.09E-03	-1.62E-03	-1.14E-03
7	-2.71E-02	-2.51E-02	-2.03E-02	-1.45E-02	-8.72E-03	-3.11E-03	2.03E-03	7.71E-03	1.34E-02	1.88E-02
8	6.36E-03	3.71E-04	-1.20E-03	-4.90E-04	1.31E-03	4.09E-03	7.50E-03	1.26E-02	1.89E-02	2.61E-02
9	3.97E-02	2.48E-02	1.57E-02	9.99E-03	6.27E-03	4.32E-03	3.69E-03	5.39E-03	8.91E-03	1.40E-02
10	6.96E-02	4.50E-02	2.74E-02	1.40E-02	3.30E-03	-5.23E-03	-1.21E-02	-1.66E-02	-1.92E-02	-2.03E-02

Low	1	2	3	4	5	6	7	8	9	10
1	9.60E-03	1.74E-02	2.94E-02	3.90E-02	4.48E-02	3.86E-02	3.41E-02	2.50E-02	1.08E-02	-8.46E-03
2	-4.41E-02	-3.49E-02	-2.29E-02	-1.24E-02	-4.41E-03	6.43E-04	-4.91E-03	-6.58E-03	-1.13E-02	-1.96E-02
3	-3.74E-02	-3.40E-02	-2.66E-02	-1.91E-02	-1.23E-02	-6.65E-03	-2.05E-03	1.58E-03	-4.03E-03	-3.20E-03
4	-4.57E-04	-7.01E-03	-7.71E-03	-6.53E-03	-4.42E-03	-1.70E-03	1.62E-03	5.77E-03	1.08E-02	1.65E-02
5	4.76E-02	2.81E-02	1.62E-02	7.87E-03	1.64E-03	-2.78E-03	-5.55E-03	-6.54E-03	-5.72E-03	-3.22E-03

High	1	2	3	4	5	6	7	8	9	10
6	-1.60E-02	-1.01E-02	-2.82E-03	3.76E-03	8.45E-03	1.10E-02	1.07E-02	8.30E-03	2.77E-03	-6.74E-03
7	-1.46E-02	-1.32E-02	-9.32E-03	-4.95E-03	-1.34E-03	1.24E-03	2.16E-03	2.11E-03	1.37E-04	-4.64E-03
8	-4.23E-03	-7.83E-03	-7.75E-03	-6.11E-03	-4.20E-03	-2.29E-03	-9.55E-04	5.07E-04	1.18E-03	2.16E-04
9	1.22E-02	3.16E-03	-1.11E-03	-2.82E-03	-3.30E-03	-2.87E-03	-2.09E-03	-2.24E-04	1.87E-03	3.36E-03
10	3.23E-02	1.73E-02	8.11E-03	2.42E-03	-1.24E-03	-3.22E-03	-4.12E-03	-3.18E-03	-1.25E-03	9.05E-04

Lead followed by aluminum

65 keV Pb-Al Dose (Fractional Difference)

Full	1	2	3	4	5	6	7	8	9	10
1	1.18E-02	1.78E-02	2.68E-02	3.07E-02	2.93E-02	2.40E-02	1.62E-02	6.94E-03	-2.80E-03	-1.23E-02
2	-1.43E-02	-4.79E-03	7.29E-03	1.41E-02	1.56E-02	1.33E-02	8.38E-03	2.10E-03	-4.70E-03	-1.12E-02
3	-2.74E-02	-1.81E-02	-5.06E-03	3.24E-03	6.68E-03	6.43E-03	3.76E-03	-1.40E-04	-4.44E-03	-8.29E-03
4	-3.11E-02	-2.43E-02	-1.19E-02	-3.21E-03	1.23E-03	2.37E-03	1.38E-03	-6.28E-04	-2.84E-03	-4.40E-03
5	-2.74E-02	-2.49E-02	-1.44E-02	-6.31E-03	-1.64E-03	2.73E-04	4.17E-04	-1.43E-04	-6.53E-04	-2.57E-04
6	-1.76E-02	-2.12E-02	-1.37E-02	-6.92E-03	-2.69E-03	-5.79E-04	2.67E-04	7.09E-04	1.51E-03	3.52E-03
7	-3.15E-03	-1.41E-02	-1.05E-02	-5.88E-03	-2.71E-03	-9.44E-04	6.06E-05	1.08E-03	2.79E-03	6.03E-03
8	1.50E-02	-4.50E-03	-5.63E-03	-3.83E-03	-2.30E-03	-1.39E-03	-6.81E-04	4.64E-04	2.68E-03	6.73E-03
9	3.57E-02	6.64E-03	6.10E-05	-1.54E-03	-2.16E-03	-2.59E-03	-2.62E-03	-1.76E-03	5.17E-04	4.96E-03
10	5.79E-02	1.85E-02	5.93E-03	4.15E-04	-2.82E-03	-5.01E-03	-6.22E-03	-6.07E-03	-4.15E-03	2.36E-04

Low	1	2	3	4	5	6	7	8	9	10
1	4.61E-04	-6.40E-04	6.26E-03	1.06E-02	1.15E-02	9.56E-03	5.94E-03	1.62E-03	-2.64E-03	-6.08E-03
2	-1.33E-02	-1.40E-02	-6.03E-03	-4.03E-05	2.78E-03	3.10E-03	1.90E-03	1.81E-04	-1.33E-03	-1.82E-03
3	-9.21E-03	-1.51E-02	-9.32E-03	-4.06E-03	-1.04E-03	6.90E-05	8.85E-05	-8.53E-05	2.49E-04	1.90E-03
4	7.99E-03	-6.98E-03	-6.03E-03	-3.42E-03	-1.75E-03	-1.13E-03	-1.01E-03	-6.21E-04	6.50E-04	3.58E-03
5	3.50E-02	7.76E-03	1.78E-03	1.40E-04	-8.83E-04	-1.91E-03	-2.73E-03	-2.72E-03	-1.42E-03	1.89E-03

High	1	2	3	4	5	6	7	8	9	10
6	-8.29E-03	-8.91E-03	-1.06E-03	4.54E-03	6.73E-03	6.22E-03	4.04E-03	1.15E-03	-1.61E-03	-3.40E-03
7	-5.13E-03	-9.90E-03	-3.93E-03	9.89E-04	3.22E-03	3.23E-03	1.92E-03	1.96E-04	-1.16E-03	-1.30E-03
8	1.87E-03	-7.96E-03	-4.53E-03	-8.07E-04	1.05E-03	1.22E-03	4.73E-04	-3.72E-04	-5.70E-04	7.21E-04
9	1.19E-02	-3.83E-03	-3.48E-03	-1.42E-03	-3.26E-04	-3.26E-04	-8.12E-04	-1.04E-03	-3.36E-04	2.15E-03
10	2.43E-02	2.00E-03	-1.25E-03	-1.26E-03	-1.30E-03	-1.79E-03	-2.31E-03	-2.20E-03	-8.41E-04	2.59E-03

100 keV Pb-AI Dose (Fractional Difference)

Full	1	2	3	4	5	6	7	8	9	10
1	7.72E-02	1.16E-01	1.22E-01	1.10E-01	8.85E-02	6.48E-02	4.25E-02	2.42E-02	1.14E-02	5.24E-03
2	-5.19E-02	3.13E-03	2.00E-02	1.51E-02	-7.75E-04	-2.08E-02	-4.07E-02	-5.80E-02	-7.09E-02	-7.83E-02
3	-9.49E-02	-3.40E-02	-1.03E-02	-1.01E-02	-2.27E-02	-4.12E-02	-6.08E-02	-7.87E-02	-9.31E-02	-1.03E-01
4	-9.63E-02	-3.55E-02	-5.74E-03	9.90E-04	-6.80E-03	-2.23E-02	-4.07E-02	-5.87E-02	-7.40E-02	-8.52E-02
5	-7.64E-02	-2.38E-02	9.93E-03	2.45E-02	2.45E-02	1.54E-02	1.50E-03	-1.37E-02	-2.76E-02	-3.83E-02
6	-4.62E-02	-1.19E-02	1.99E-02	4.06E-02	5.03E-02	5.12E-02	4.64E-02	3.87E-02	3.07E-02	2.44E-02
7	-1.09E-02	-6.31E-03	1.47E-02	3.58E-02	5.27E-02	6.45E-02	7.19E-02	7.63E-02	7.95E-02	8.33E-02
8	2.78E-02	-7.51E-03	-6.87E-03	6.09E-03	2.34E-02	4.17E-02	5.98E-02	7.73E-02	9.48E-02	1.13E-01
9	7.10E-02	-1.26E-02	-3.99E-02	-4.33E-02	-3.38E-02	-1.67E-02	5.54E-03	3.15E-02	6.06E-02	9.29E-02
10	1.21E-01	-1.73E-02	-7.75E-02	-1.02E-01	-1.07E-01	-9.85E-02	-8.01E-02	-5.38E-02	-2.05E-02	1.94E-02

Low	1	2	3	4	5	6	7	8	9	10
1	1.84E-02	1.10E-02	5.97E-03	-8.17E-04	-7.46E-03	-1.15E-02	-1.07E-02	-3.33E-03	1.26E-02	3.88E-02
2	-2.53E-02	-6.10E-03	-1.84E-03	-5.98E-03	-1.32E-02	-1.94E-02	-2.19E-02	-1.85E-02	-7.40E-03	1.32E-02
3	-1.55E-02	1.18E-02	1.96E-02	1.54E-02	5.91E-03	-4.16E-03	-1.15E-02	-1.36E-02	-8.74E-03	4.92E-03
4	-7.87E-03	2.08E-02	3.29E-02	3.18E-02	2.33E-02	1.22E-02	2.15E-03	-4.16E-03	-4.56E-03	2.66E-03
5	-3.95E-02	-1.36E-02	4.69E-03	1.19E-02	1.05E-02	4.34E-03	-3.15E-03	-9.12E-03	-1.13E-02	-7.65E-03

High	1	2	3	4	5	6	7	8	9	10
6	-1.43E-01	-1.22E-01	-9.91E-02	-8.37E-02	-7.70E-02	-7.76E-02	-8.34E-02	-9.22E-02	-1.02E-01	-1.11E-01
7	-1.07E-01	-1.15E-01	-1.07E-01	-9.91E-02	-9.57E-02	-9.75E-02	-1.04E-01	-1.14E-01	-1.27E-01	-1.40E-01
8	-1.01E-01	-1.25E-01	-1.24E-01	-1.17E-01	-1.10E-01	-1.05E-01	-1.04E-01	-1.05E-01	-1.10E-01	-1.17E-01
9	-9.68E-02	-1.37E-01	-1.44E-01	-1.39E-01	-1.30E-01	-1.20E-01	-1.11E-01	-1.03E-01	-9.60E-02	-9.10E-02
10	-7.91E-02	-1.38E-01	-1.55E-01	-1.57E-01	-1.50E-01	-1.39E-01	-1.26E-01	-1.11E-01	-9.52E-02	-7.93E-02

500 keV Pb-AI Dose (Fractional Difference)

Full	1	2	3	4	5	6	7	8	9	10
1	1.39E-02	6.21E-02	7.84E-02	7.86E-02	7.03E-02	5.75E-02	4.21E-02	2.51E-02	7.15E-03	-1.17E-02
2	-5.53E-02	-5.84E-04	2.34E-02	3.13E-02	3.05E-02	2.48E-02	1.60E-02	5.31E-03	-6.92E-03	-2.05E-02
3	-8.37E-02	-3.18E-02	-6.43E-03	4.85E-03	8.21E-03	6.98E-03	2.83E-03	-3.35E-03	-1.12E-02	-2.06E-02
4	-8.80E-02	-4.38E-02	-2.04E-02	-8.40E-03	-2.94E-03	-1.30E-03	-2.18E-03	-4.92E-03	-9.24E-03	-1.52E-02
5	-7.59E-02	-4.30E-02	-2.39E-02	-1.30E-02	-6.93E-03	-3.65E-03	-2.28E-03	-2.37E-03	-3.84E-03	-6.84E-03
6	-5.24E-02	-3.33E-02	-2.04E-02	-1.22E-02	-6.72E-03	-2.84E-03	-7.43E-05	1.77E-03	2.55E-03	1.92E-03
7	-2.11E-02	-1.78E-02	-1.28E-02	-8.45E-03	-4.70E-03	-1.13E-03	2.19E-03	5.19E-03	7.56E-03	8.79E-03
8	1.48E-02	6.18E-04	-3.46E-03	-4.13E-03	-3.05E-03	-7.36E-04	2.33E-03	5.72E-03	8.94E-03	1.14E-02
9	5.26E-02	1.97E-02	5.49E-03	-1.16E-03	-3.67E-03	-3.46E-03	-1.52E-03	1.44E-03	4.74E-03	7.60E-03
10	8.97E-02	3.73E-02	1.22E-02	-1.17E-03	-8.08E-03	-1.08E-02	-1.08E-02	-9.15E-03	-6.62E-03	-4.13E-03

Low	1	2	3	4	5	6	7	8	9	10
1	-1.77E-02	1.17E-02	2.39E-02	2.67E-02	2.45E-02	1.98E-02	1.34E-02	6.00E-03	-2.43E-03	-1.21E-02
2	-5.27E-02	-2.42E-02	-9.07E-03	-1.71E-03	1.51E-03	2.44E-03	1.93E-03	3.21E-04	-2.40E-03	-6.54E-03
3	-3.87E-02	-2.47E-02	-1.54E-02	-9.65E-03	-5.83E-03	-2.96E-03	-6.84E-04	1.01E-03	1.89E-03	1.50E-03
4	4.29E-03	-4.50E-03	-6.59E-03	-6.71E-03	-5.71E-03	-3.77E-03	-1.20E-03	1.59E-03	4.16E-03	5.83E-03
5	6.42E-02	2.69E-02	9.50E-03	3.09E-04	-4.20E-03	-5.62E-03	-5.01E-03	-3.16E-03	-8.39E-04	1.11E-03

High	1	2	3	4	5	6	7	8	9	10
6	-3.16E-02	-9.36E-03	2.51E-03	7.72E-03	9.10E-03	8.30E-03	6.14E-03	3.04E-03	-9.29E-04	-5.91E-03
7	-2.29E-02	-1.03E-02	-2.48E-03	1.36E-03	2.80E-03	3.01E-03	2.39E-03	1.18E-03	-6.41E-04	-3.36E-03
8	-7.70E-03	-5.96E-03	-3.24E-03	-1.58E-03	-7.05E-04	-1.10E-04	3.32E-04	5.98E-04	5.20E-04	-2.33E-04
9	1.22E-02	1.93E-03	-1.22E-03	-2.47E-03	-2.78E-03	-2.32E-03	-1.32E-03	-9.58E-06	1.30E-03	2.15E-03
10	3.53E-02	1.20E-02	2.24E-03	-2.54E-03	-4.61E-03	-4.82E-03	-3.75E-03	-1.84E-03	4.32E-04	2.52E-03

1 MeV Pb-Al Dose (Fractional Difference)

Full	1	2	3	4	5	6	7	8	9	10
1	9.05E-02	1.12E-01	1.11E-01	9.76E-02	7.96E-02	5.98E-02	3.99E-02	2.06E-02	2.31E-03	-1.48E-02
2	-1.90E-02	2.24E-02	3.72E-02	3.83E-02	3.24E-02	2.29E-02	1.17E-02	6.14E-05	-1.16E-02	-2.28E-02
3	-6.71E-02	-2.26E-02	-1.68E-03	6.17E-03	6.86E-03	3.56E-03	-1.88E-03	-8.38E-03	-1.53E-02	-2.22E-02
4	-8.19E-02	-4.11E-02	-1.93E-02	-8.74E-03	-4.57E-03	-4.15E-03	-5.87E-03	-8.76E-03	-1.22E-02	-1.58E-02
5	-7.57E-02	-4.29E-02	-2.34E-02	-1.26E-02	-7.05E-03	-4.60E-03	-3.97E-03	-4.35E-03	-5.23E-03	-6.30E-03
6	-5.60E-02	-3.41E-02	-1.92E-02	-1.01E-02	-4.58E-03	-1.34E-03	5.89E-04	1.82E-03	2.74E-03	3.57E-03
7	-2.81E-02	-1.93E-02	-1.08E-02	-4.74E-03	-5.82E-04	2.41E-03	4.77E-03	6.84E-03	8.92E-03	1.11E-02
8	3.44E-03	-2.62E-03	-1.85E-03	-7.03E-05	1.80E-03	3.69E-03	5.71E-03	7.96E-03	1.06E-02	1.35E-02
9	3.45E-02	1.24E-02	4.45E-03	1.09E-03	-1.46E-04	-1.00E-04	9.01E-04	2.71E-03	5.26E-03	8.45E-03
10	6.12E-02	2.26E-02	5.32E-03	-3.79E-03	-8.73E-03	-1.11E-02	-1.17E-02	-1.09E-02	-8.93E-03	-6.02E-03

Low	1	2	3	4	5	6	7	8	9	10
1	7.87E-03	2.91E-02	3.53E-02	3.34E-02	2.75E-02	1.98E-02	1.13E-02	2.54E-03	-6.25E-03	-1.50E-02
2	-5.09E-02	-2.31E-02	-8.16E-03	-9.53E-04	1.89E-03	2.23E-03	1.08E-03	-9.72E-04	-3.66E-03	-6.89E-03
3	-4.33E-02	-2.84E-02	-1.73E-02	-9.93E-03	-5.09E-03	-1.85E-03	3.41E-04	1.79E-03	2.62E-03	2.85E-03
4	-1.31E-03	-9.02E-03	-8.77E-03	-6.79E-03	-4.35E-03	-1.78E-03	7.70E-04	3.20E-03	5.42E-03	7.27E-03
5	5.62E-02	2.05E-02	5.61E-03	-1.31E-03	-4.30E-03	-5.09E-03	-4.53E-03	-3.19E-03	-1.44E-03	3.60E-04

High	1	2	3	4	5	6	7	8	9	10
6	-1.43E-02	-2.35E-03	5.20E-03	8.28E-03	8.42E-03	6.77E-03	4.12E-03	9.79E-04	-2.32E-03	-5.61E-03
7	-1.40E-02	-7.28E-03	-1.42E-03	1.66E-03	2.67E-03	2.38E-03	1.35E-03	-3.17E-05	-1.49E-03	-2.93E-03
8	-6.12E-03	-6.21E-03	-3.19E-03	-1.06E-03	4.74E-05	4.31E-04	4.40E-04	3.12E-04	2.36E-04	2.86E-04
9	6.53E-03	-1.50E-03	-2.24E-03	-1.83E-03	-1.31E-03	-8.17E-04	-2.74E-04	4.19E-04	1.35E-03	2.53E-03
10	2.16E-02	4.65E-03	-6.35E-04	-2.58E-03	-3.19E-03	-3.10E-03	-2.45E-03	-1.34E-03	2.38E-04	2.23E-03

2 MeV Pb-Al Dose (Fractional Difference)

Full	1	2	3	4	5	6	7	8	9	10
1	1.22E-01	1.14E-01	9.94E-02	8.04E-02	6.02E-02	4.04E-02	2.17E-02	4.64E-03	-1.07E-02	-2.43E-02
2	6.04E-03	2.71E-02	3.39E-02	3.18E-02	2.47E-02	1.53E-02	4.99E-03	-5.27E-03	-1.49E-02	-2.37E-02
3	-4.73E-02	-1.79E-02	-1.84E-03	4.67E-03	5.23E-03	2.34E-03	-2.34E-03	-7.80E-03	-1.33E-02	-1.85E-02
4	-6.54E-02	-3.70E-02	-1.82E-02	-7.85E-03	-3.20E-03	-2.15E-03	-3.20E-03	-5.38E-03	-7.92E-03	-1.04E-02
5	-6.14E-02	-3.93E-02	-2.19E-02	-1.08E-02	-4.44E-03	-1.35E-03	-2.71E-04	-3.28E-04	-8.29E-04	-1.32E-03
6	-4.36E-02	-3.11E-02	-1.78E-02	-8.10E-03	-1.85E-03	1.86E-03	3.95E-03	5.10E-03	5.89E-03	6.75E-03
7	-1.84E-02	-1.76E-02	-1.02E-02	-3.46E-03	1.44E-03	4.76E-03	7.00E-03	8.65E-03	1.02E-02	1.18E-02
8	8.79E-03	-3.40E-03	-2.93E-03	-1.35E-04	2.58E-03	4.78E-03	6.56E-03	8.19E-03	9.96E-03	1.21E-02
9	3.33E-02	7.87E-03	9.01E-04	-7.36E-04	-6.82E-04	-5.16E-05	8.93E-04	2.14E-03	3.85E-03	6.16E-03
10	5.11E-02	1.30E-02	-1.27E-03	-7.42E-03	-1.02E-02	-1.13E-02	-1.14E-02	-1.08E-02	-9.34E-03	-7.10E-03

Low	1	2	3	4	5	6	7	8	9	10
1	2.79E-02	3.17E-02	3.07E-02	2.60E-02	1.94E-02	1.22E-02	4.92E-03	-1.96E-03	-8.23E-03	-1.38E-02
2	-3.58E-02	-1.86E-02	-7.30E-03	-1.34E-03	1.07E-03	1.37E-03	5.02E-04	-9.18E-04	-2.49E-03	-3.97E-03
3	-3.38E-02	-2.49E-02	-1.50E-02	-7.76E-03	-3.05E-03	-9.87E-05	1.73E-03	2.90E-03	3.77E-03	4.56E-03
4	-8.33E-04	-9.54E-03	-8.03E-03	-4.93E-03	-2.09E-03	2.26E-04	2.11E-03	3.71E-03	5.24E-03	6.81E-03
5	4.19E-02	1.21E-02	1.90E-03	-1.98E-03	-3.45E-03	-3.86E-03	-3.71E-03	-3.18E-03	-2.30E-03	-1.08E-03

High	1	2	3	4	5	6	7	8	9	10
6	-5.72E-03	1.50E-04	6.13E-03	8.56E-03	8.04E-03	5.65E-03	2.37E-03	-1.10E-03	-4.20E-03	-6.57E-03
7	-9.14E-03	-6.31E-03	-7.47E-04	2.49E-03	3.36E-03	2.63E-03	1.10E-03	-5.97E-04	-1.95E-03	-2.60E-03
8	-4.61E-03	-6.69E-03	-3.02E-03	-1.84E-04	1.09E-03	1.21E-03	7.89E-04	3.24E-04	2.88E-04	9.48E-04
9	4.81E-03	-3.55E-03	-2.86E-03	-1.32E-03	-3.78E-04	-6.33E-06	1.71E-04	5.20E-04	1.43E-03	3.19E-03
10	1.61E-02	5.82E-04	-2.47E-03	-2.85E-03	-2.76E-03	-2.58E-03	-2.18E-03	-1.34E-03	2.31E-04	2.75E-03

6 MeV Pb-Al Dose (Fractional Difference)

Full	1	2	3	4	5	6	7	8	9	10
1	3.46E-02	4.76E-02	4.28E-02	3.19E-02	2.03E-02	1.05E-02	3.80E-03	8.65E-04	2.12E-03	7.88E-03
2	-2.58E-02	4.04E-03	1.04E-02	7.11E-03	9.67E-04	-4.69E-03	-8.14E-03	-8.42E-03	-4.92E-03	2.80E-03
3	-4.34E-02	-1.19E-02	-2.51E-03	-3.09E-03	-7.04E-03	-1.09E-02	-1.29E-02	-1.18E-02	-7.18E-03	1.53E-03
4	-3.79E-02	-1.12E-02	-2.79E-03	-3.46E-03	-7.20E-03	-1.08E-02	-1.25E-02	-1.11E-02	-6.25E-03	2.69E-03
5	-2.29E-02	-2.41E-03	3.49E-03	1.59E-03	-2.91E-03	-7.02E-03	-9.07E-03	-8.12E-03	-3.55E-03	5.10E-03
6	-7.57E-03	7.57E-03	1.13E-02	8.18E-03	2.80E-03	-2.06E-03	-4.77E-03	-4.45E-03	-4.90E-04	7.54E-03
7	1.99E-03	1.40E-02	1.67E-02	1.32E-02	7.35E-03	2.02E-03	-1.26E-03	-1.50E-03	1.70E-03	8.98E-03
8	2.47E-03	1.37E-02	1.72E-02	1.43E-02	8.89E-03	3.59E-03	9.59E-05	-5.52E-04	2.14E-03	8.69E-03
9	-7.52E-03	5.23E-03	1.10E-02	1.01E-02	5.98E-03	1.49E-03	-1.71E-03	-2.48E-03	-1.23E-04	5.83E-03
10	-2.77E-02	-1.17E-02	-2.25E-03	-1.41E-04	-2.02E-03	-5.04E-03	-7.37E-03	-7.77E-03	-5.44E-03	1.45E-04

Low	1	2	3	4	5	6	7	8	9	10
1	3.52E-02	1.89E-02	1.02E-02	4.67E-03	1.01E-03	-1.30E-03	-2.48E-03	-2.69E-03	-1.97E-03	-3.72E-04
2	-1.12E-02	-7.25E-03	-5.36E-03	-4.66E-03	-4.29E-03	-3.79E-03	-2.88E-03	-1.45E-03	6.05E-04	3.32E-03
3	-1.83E-02	-8.85E-03	-4.17E-03	-2.32E-03	-1.59E-03	-1.10E-03	-4.01E-04	8.47E-04	2.63E-03	5.06E-03
4	-1.08E-02	-1.07E-03	3.11E-03	3.78E-03	3.01E-03	1.93E-03	1.10E-03	9.20E-04	1.38E-03	2.59E-03
5	-4.21E-03	4.85E-03	8.09E-03	7.19E-03	4.50E-03	1.40E-03	-1.37E-03	-3.51E-03	-4.84E-03	-5.31E-03

High	1	2	3	4	5	6	7	8	9	10
6	-1.43E-02	2.59E-03	7.51E-03	5.31E-03	6.94E-04	-3.45E-03	-5.47E-03	-4.41E-03	3.68E-04	9.32E-03
7	-7.21E-03	5.40E-03	8.72E-03	5.64E-03	3.22E-04	-4.51E-03	-7.28E-03	-6.95E-03	-3.13E-03	4.83E-03
8	-4.26E-03	6.75E-03	1.01E-02	7.25E-03	1.94E-03	-3.16E-03	-6.39E-03	-6.70E-03	-3.61E-03	3.43E-03
9	-7.40E-03	4.39E-03	9.46E-03	8.00E-03	3.55E-03	-1.12E-03	-4.36E-03	-5.05E-03	-2.50E-03	3.76E-03
10	-1.72E-02	-2.77E-03	5.44E-03	6.52E-03	3.84E-03	2.41E-04	-2.47E-03	-3.06E-03	-7.56E-04	4.99E-03

10 MeV Pb-Al Dose (Fractional Difference)

Full	1	2	3	4	5	6	7	8	9	10
1	-2.67E-02	7.05E-02	7.37E-02	5.31E-02	2.93E-02	9.30E-03	-4.52E-03	-1.12E-02	-1.03E-02	-1.21E-03
2	-6.77E-02	3.52E-02	4.73E-02	3.33E-02	1.43E-02	-2.22E-03	-1.33E-02	-1.78E-02	-1.49E-02	-4.05E-03
3	-7.51E-02	1.79E-02	3.22E-02	2.16E-02	5.40E-03	-8.78E-03	-1.79E-02	-2.07E-02	-1.63E-02	-4.14E-03
4	-6.25E-02	1.27E-02	2.52E-02	1.58E-02	1.31E-03	-1.13E-02	-1.91E-02	-2.07E-02	-1.51E-02	-1.81E-03
5	-4.03E-02	1.42E-02	2.31E-02	1.39E-02	4.59E-04	-1.10E-02	-1.78E-02	-1.83E-02	-1.19E-02	2.38E-03
6	-1.68E-02	1.76E-02	2.27E-02	1.37E-02	1.28E-03	-9.12E-03	-1.49E-02	-1.45E-02	-7.20E-03	7.89E-03
7	1.57E-03	1.88E-02	2.12E-02	1.31E-02	2.14E-03	-6.93E-03	-1.15E-02	-1.01E-02	-1.93E-03	1.40E-02
8	1.03E-02	1.47E-02	1.63E-02	1.03E-02	1.61E-03	-5.49E-03	-8.48E-03	-5.86E-03	3.42E-03	2.03E-02
9	6.45E-03	2.87E-03	5.99E-03	3.50E-03	-1.75E-03	-6.08E-03	-6.93E-03	-2.64E-03	7.99E-03	2.60E-02
10	-1.14E-02	-1.81E-02	-1.12E-02	-8.53E-03	-9.17E-03	-9.80E-03	-7.81E-03	-1.33E-03	1.10E-02	3.04E-02

Low	1	2	3	4	5	6	7	8	9	10
1	2.60E-02	1.98E-02	9.87E-03	9.20E-04	-5.70E-03	-9.33E-03	-9.59E-03	-6.26E-03	9.20E-04	1.22E-02
2	-1.54E-02	2.78E-03	2.91E-03	-1.93E-03	-6.91E-03	-9.97E-03	-1.02E-02	-7.15E-03	-3.68E-04	1.04E-02
3	-2.48E-02	6.09E-03	1.10E-02	6.83E-03	7.88E-04	-4.07E-03	-6.33E-03	-5.32E-03	-6.40E-04	7.96E-03
4	-3.01E-02	1.11E-02	2.06E-02	1.70E-02	9.56E-03	2.41E-03	-2.52E-03	-4.34E-03	-2.56E-03	3.04E-03
5	-4.69E-02	5.46E-03	2.17E-02	2.06E-02	1.31E-02	4.47E-03	-2.67E-03	-7.13E-03	-8.28E-03	-5.84E-03

High	1	2	3	4	5	6	7	8	9	10
6	-3.46E-02	1.43E-02	2.65E-02	2.11E-02	1.00E-02	-3.37E-04	-6.98E-03	-8.32E-03	-3.41E-03	8.45E-03
7	-1.46E-02	1.09E-02	1.83E-02	1.28E-02	2.79E-03	-6.49E-03	-1.22E-02	-1.28E-02	-7.41E-03	4.77E-03
8	-1.59E-03	8.02E-03	1.28E-02	8.20E-03	-2.54E-04	-8.16E-03	-1.28E-02	-1.27E-02	-6.71E-03	5.83E-03
9	2.98E-03	2.77E-03	7.38E-03	5.03E-03	-1.06E-03	-7.04E-03	-1.03E-02	-9.09E-03	-2.40E-03	1.07E-02
10	-1.08E-03	-6.45E-03	1.48E-04	1.44E-03	-1.28E-03	-4.58E-03	-5.82E-03	-3.19E-03	4.58E-03	1.85E-02

Polyethylene followed by Lead

65 keV Poly-Pb Dose (Fractional Difference)

Full	1	2	3	4	5	6	7	8	9	10
1	1.33E-01	1.17E-01	8.52E-02	5.93E-02	4.21E-02	3.31E-02	3.19E-02	3.82E-02	5.18E-02	7.39E-02
2	4.92E-03	3.79E-02	2.60E-02	1.10E-02	6.19E-04	4.55E-04	2.82E-03	1.20E-02	2.85E-02	5.30E-02
3	-5.16E-02	1.24E-03	-3.08E-03	-1.39E-02	-2.15E-02	-1.96E-02	-1.55E-02	-4.71E-03	1.33E-02	3.94E-02
4	-6.53E-02	-7.59E-03	-1.18E-02	-2.30E-02	-3.08E-02	-2.89E-02	-2.46E-02	-1.34E-02	5.15E-03	3.20E-02
5	-5.34E-02	9.74E-04	-7.40E-03	-2.14E-02	-3.12E-02	-3.06E-02	-2.72E-02	-1.65E-02	1.88E-03	2.89E-02
6	-2.85E-02	1.81E-02	3.82E-03	-1.42E-02	-2.66E-02	-2.79E-02	-2.59E-02	-1.63E-02	1.43E-03	2.81E-02
7	-2.33E-03	3.58E-02	1.61E-02	-5.60E-03	-2.07E-02	-2.39E-02	-2.35E-02	-1.50E-02	1.74E-03	2.77E-02
8	1.38E-02	4.70E-02	2.43E-02	3.49E-04	-1.23E-02	-2.13E-02	-2.22E-02	-1.49E-02	9.43E-04	2.61E-02
9	9.97E-03	4.58E-02	2.42E-02	3.49E-04	-1.70E-02	-2.24E-02	-2.40E-02	-1.76E-02	-2.69E-03	2.16E-02
10	-2.04E-02	2.82E-02	1.28E-02	-7.98E-03	-2.40E-02	-2.89E-02	-3.07E-02	-2.47E-02	-1.05E-02	1.29E-02

Low	1	2	3	4	5	6	7	8	9	10
1	-3.44E-03	2.15E-02	1.55E-02	5.90E-03	-1.68E-03	-5.60E-03	-5.27E-03	-3.75E-04	8.99E-03	2.40E-02
2	-3.82E-02	7.17E-03	5.65E-03	-2.73E-03	-9.77E-03	-9.25E-03	-8.43E-03	-2.87E-03	7.75E-03	2.39E-02
3	-2.43E-02	1.95E-02	1.28E-02	6.58E-04	-8.82E-03	-9.78E-03	-9.82E-03	-4.64E-03	6.01E-03	2.25E-02
4	-1.89E-03	3.47E-02	2.09E-02	3.97E-03	-8.75E-03	-1.19E-02	-1.35E-02	-9.35E-03	6.06E-04	1.67E-02
5	-8.25E-03	3.15E-02	1.62E-02	-2.68E-03	-1.70E-02	-2.16E-02	-2.43E-02	-2.12E-02	-1.21E-02	3.17E-03

High	1	2	3	4	5	6	7	8	9	10
6	-2.78E-03	-1.08E-02	-9.34E-03	-5.76E-03	-9.96E-04	9.26E-03	1.69E-02	2.67E-02	3.89E-02	5.42E-02
7	9.08E-04	-3.10E-03	-8.47E-03	-1.13E-02	-1.17E-02	-5.52E-03	-1.22E-03	5.69E-03	1.55E-02	2.85E-02
8	1.09E-03	6.80E-03	-2.15E-03	-9.85E-03	-1.04E-02	-1.24E-02	-1.14E-02	-7.35E-03	-1.40E-04	1.05E-02
9	-1.44E-03	1.68E-02	6.84E-03	-4.28E-03	-1.27E-02	-1.38E-02	-1.58E-02	-1.46E-02	-9.88E-03	-1.59E-03
10	-5.49E-03	2.61E-02	1.69E-02	3.64E-03	-7.63E-03	-1.15E-02	-1.63E-02	-1.75E-02	-1.52E-02	-9.16E-03

100 keV Poly-Pb Dose (Fractional Difference)

Full	1	2	3	4	5	6	7	8	9	10
1	3.00E-01	3.39E-01	3.44E-01	3.21E-01	2.75E-01	2.15E-01	1.49E-01	8.91E-02	4.67E-02	3.44E-02
2	-1.98E-02	6.92E-02	1.00E-01	9.21E-02	5.38E-02	6.21E-03	-4.29E-02	-8.15E-02	-9.76E-02	-7.63E-02
3	-1.71E-01	-5.97E-02	-1.69E-02	-1.68E-02	-4.65E-02	-8.34E-02	-1.18E-01	-1.37E-01	-1.27E-01	-6.81E-02
4	-2.34E-01	-1.03E-01	-5.13E-02	-4.53E-02	-6.87E-02	-9.72E-02	-1.19E-01	-1.21E-01	-8.44E-02	1.73E-02
5	-2.42E-01	-9.19E-02	-3.17E-02	-2.21E-02	-4.26E-02	-6.63E-02	-8.00E-02	-6.74E-02	-7.42E-03	1.36E-01
6	-2.16E-01	-4.48E-02	2.14E-02	3.06E-02	8.00E-03	-1.64E-02	-2.81E-02	-9.00E-03	6.44E-02	2.34E-01
7	-1.71E-01	2.04E-02	8.83E-02	9.13E-02	5.98E-02	2.71E-02	8.57E-03	2.24E-02	9.17E-02	2.57E-01
8	-1.22E-01	8.51E-02	1.48E-01	1.38E-01	9.09E-02	4.21E-02	7.49E-03	3.62E-03	4.98E-02	1.78E-01
9	-8.46E-02	1.32E-01	1.83E-01	1.54E-01	8.53E-02	1.54E-02	-4.11E-02	-7.04E-02	-5.88E-02	1.47E-02
10	-6.89E-02	1.47E-01	1.81E-01	1.29E-01	3.83E-02	-5.30E-02	-1.31E-01	-1.86E-01	-2.09E-01	-1.88E-01

Low	1	2	3	4	5	6	7	8	9	10
1	1.26E-01	1.28E-01	1.15E-01	9.28E-02	6.43E-02	3.26E-02	2.70E-03	-1.98E-02	-2.88E-02	-1.77E-02
2	-9.32E-02	-3.26E-02	-1.28E-02	-1.44E-02	-3.15E-02	-4.76E-02	-5.86E-02	-5.61E-02	-3.13E-02	2.66E-02
3	-1.54E-01	-5.77E-02	-1.95E-02	-1.13E-02	-2.22E-02	-3.25E-02	-3.56E-02	-2.14E-02	2.07E-02	1.04E-01
4	-1.35E-01	-7.25E-03	4.19E-02	4.98E-02	3.26E-02	1.30E-02	-1.10E-03	1.43E-04	2.59E-02	8.66E-02
5	-8.04E-02	7.30E-02	1.22E-01	1.15E-01	7.53E-02	2.79E-02	-1.83E-02	-5.46E-02	-7.52E-02	-7.55E-02

High	1	2	3	4	5	6	7	8	9	10
6	-1.23E-01	-2.08E-02	-2.16E-02	-6.30E-02	-1.17E-01	-1.58E-01	-1.78E-01	-1.69E-01	-1.31E-01	-7.20E-02
7	-1.97E-01	-7.72E-02	-6.14E-02	-8.81E-02	-1.29E-01	-1.59E-01	-1.70E-01	-1.56E-01	-1.19E-01	-7.25E-02
8	-2.43E-01	-1.05E-01	-7.47E-02	-8.90E-02	-1.20E-01	-1.43E-01	-1.50E-01	-1.38E-01	-1.11E-01	-8.72E-02
9	-2.69E-01	-1.14E-01	-6.98E-02	-7.41E-02	-9.84E-02	-1.18E-01	-1.27E-01	-1.23E-01	-1.14E-01	-1.19E-01
10	-2.83E-01	-1.10E-01	-5.28E-02	-4.93E-02	-7.01E-02	-9.05E-02	-1.06E-01	-1.16E-01	-1.30E-01	-1.66E-01

500 keV Poly-Pb Dose (Fractional Difference)

Full	1	2	3	4	5	6	7	8	9	10
1	4.04E-02	7.45E-02	6.85E-02	5.19E-02	3.37E-02	1.73E-02	4.26E-03	-4.92E-03	-9.45E-03	-9.16E-03
2	-3.39E-02	2.03E-02	2.86E-02	2.25E-02	1.23E-02	2.26E-03	-5.65E-03	-1.05E-02	-1.12E-02	-7.49E-03
3	-5.66E-02	-3.14E-03	8.41E-03	6.49E-03	3.72E-04	-6.13E-03	-1.07E-02	-1.23E-02	-1.02E-02	-3.79E-03
4	-5.03E-02	-7.47E-03	1.39E-03	-1.72E-04	-4.78E-03	-9.17E-03	-1.18E-02	-1.14E-02	-7.23E-03	1.18E-03
5	-2.96E-02	-1.05E-03	2.35E-03	-9.14E-04	-5.54E-03	-9.35E-03	-1.07E-02	-8.88E-03	-3.32E-03	6.59E-03
6	-6.04E-03	9.31E-03	6.84E-03	1.17E-03	-4.17E-03	-7.82E-03	-8.38E-03	-5.92E-03	6.33E-04	1.16E-02
7	1.14E-02	1.80E-02	1.11E-02	3.46E-03	-2.61E-03	-6.14E-03	-6.52E-03	-3.48E-03	3.77E-03	1.56E-02
8	1.63E-02	2.09E-02	1.23E-02	3.76E-03	-2.55E-03	-5.94E-03	-5.97E-03	-2.45E-03	5.34E-03	1.77E-02
9	5.51E-03	1.54E-02	8.29E-03	1.24E-03	-5.95E-03	-8.43E-03	-7.58E-03	-3.02E-03	5.62E-03	1.70E-02
10	-2.04E-02	1.25E-03	-2.75E-03	-7.69E-03	-1.15E-02	-1.29E-02	-1.13E-02	-7.80E-03	1.35E-03	1.49E-02

Low	1	2	3	4	5	6	7	8	9	10
1	-1.64E-02	2.88E-02	3.00E-02	1.96E-02	7.35E-03	-2.90E-03	-9.49E-03	-1.17E-02	-8.51E-03	5.73E-04
2	-3.64E-02	8.79E-03	1.39E-02	7.91E-03	-2.57E-04	-6.92E-03	-1.04E-02	-9.66E-03	-3.73E-03	8.01E-03
3	-1.93E-02	1.23E-02	1.30E-02	6.19E-03	-1.42E-03	-7.18E-03	-9.28E-03	-7.00E-03	3.76E-04	1.36E-02
4	-3.45E-03	1.84E-02	1.48E-02	6.19E-03	-1.92E-03	-7.37E-03	-9.24E-03	-6.44E-03	1.51E-03	1.53E-02
5	-9.72E-03	1.39E-02	1.03E-02	1.76E-03	-6.19E-03	-1.16E-02	-1.31E-02	-1.01E-02	-2.04E-03	1.17E-02

High	1	2	3	4	5	6	7	8	9	10
6	-1.36E-02	1.44E-03	6.97E-03	7.72E-03	6.30E-03	4.33E-03	3.57E-03	4.18E-03	7.34E-03	1.34E-02
7	-3.02E-03	2.36E-03	2.36E-03	5.12E-04	-1.94E-03	-3.93E-03	-4.62E-03	-3.55E-03	1.42E-04	6.74E-03
8	2.35E-03	5.66E-03	2.44E-03	-1.46E-03	-5.01E-03	-7.48E-03	-8.30E-03	-7.15E-03	-3.28E-03	3.53E-03
9	1.24E-03	8.74E-03	4.76E-03	5.05E-04	-5.29E-03	-7.89E-03	-8.62E-03	-7.06E-03	-2.86E-03	2.58E-03
10	-5.91E-03	1.08E-02	6.85E-03	2.26E-03	-2.00E-03	-4.89E-03	-5.84E-03	-6.20E-03	-2.11E-03	5.00E-03

1 MeV Poly-Pb Dose (Fractional Difference)

Full	1	2	3	4	5	6	7	8	9	10
1	7.63E-02	8.53E-02	7.09E-02	5.11E-02	3.19E-02	1.58E-02	3.95E-03	-3.06E-03	-4.70E-03	-5.95E-04
2	-2.23E-02	1.90E-02	2.36E-02	1.63E-02	6.08E-03	-3.12E-03	-9.38E-03	-1.17E-02	-9.17E-03	-1.20E-03
3	-5.84E-02	-8.54E-03	2.32E-03	8.32E-05	-5.93E-03	-1.15E-02	-1.46E-02	-1.40E-02	-8.73E-03	2.00E-03
4	-6.04E-02	-1.25E-02	-2.05E-03	-3.69E-03	-8.59E-03	-1.29E-02	-1.45E-02	-1.23E-02	-5.27E-03	7.29E-03
5	-4.50E-02	-3.43E-03	3.31E-03	-1.52E-04	-5.80E-03	-1.01E-02	-1.15E-02	-8.54E-03	-6.59E-04	1.30E-02
6	-2.42E-02	1.04E-02	1.25E-02	6.24E-03	-9.91E-04	-6.13E-03	-7.68E-03	-4.82E-03	3.50E-03	1.75E-02
7	-7.02E-03	2.23E-02	2.11E-02	1.20E-02	3.01E-03	-3.29E-03	-5.58E-03	-3.10E-03	5.57E-03	1.96E-02
8	7.60E-04	2.80E-02	2.46E-02	1.40E-02	3.78E-03	-3.33E-03	-6.19E-03	-4.12E-03	4.22E-03	1.79E-02
9	-4.30E-03	2.45E-02	2.12E-02	1.03E-02	-2.37E-04	-7.67E-03	-1.09E-02	-9.16E-03	-1.24E-03	1.20E-02
10	-2.25E-02	1.09E-02	9.96E-03	2.24E-04	-9.67E-03	-1.69E-02	-2.00E-02	-1.85E-02	-1.10E-02	1.59E-03

Low	1	2	3	4	5	6	7	8	9	10
1	2.01E-02	2.92E-02	2.29E-02	1.26E-02	2.69E-03	-5.01E-03	-9.28E-03	-9.49E-03	-4.88E-03	5.11E-03
2	-3.36E-02	-1.47E-03	3.75E-03	4.47E-04	-4.85E-03	-9.07E-03	-1.06E-02	-8.43E-03	-1.67E-03	1.04E-02
3	-3.31E-02	3.28E-03	9.07E-03	5.52E-03	-1.84E-04	-4.80E-03	-6.64E-03	-4.77E-03	1.77E-03	1.36E-02
4	-2.24E-02	1.49E-02	1.90E-02	1.32E-02	5.44E-03	-1.10E-03	-4.73E-03	-4.53E-03	3.70E-04	1.05E-02
5	-2.34E-02	1.70E-02	2.09E-02	1.39E-02	4.39E-03	-4.03E-03	-9.70E-03	-1.15E-02	-8.86E-03	-1.17E-03

High	1	2	3	4	5	6	7	8	9	10
6	-2.64E-02	1.46E-02	1.96E-02	1.40E-02	5.87E-03	-1.31E-03	-5.91E-03	-7.05E-03	-3.79E-03	3.93E-03
7	-2.61E-02	1.13E-02	1.56E-02	9.89E-03	2.39E-03	-3.77E-03	-7.10E-03	-6.74E-03	-1.30E-03	8.29E-03
8	-1.88E-02	1.26E-02	1.41E-02	7.27E-03	-2.25E-04	-5.79E-03	-8.16E-03	-6.59E-03	2.46E-04	1.14E-02
9	-9.21E-03	1.50E-02	1.28E-02	4.47E-03	-3.42E-03	-8.71E-03	-1.04E-02	-7.90E-03	7.51E-05	1.25E-02
10	-1.27E-03	1.58E-02	9.94E-03	-3.76E-06	-8.37E-03	-1.35E-02	-1.46E-02	-1.14E-02	-2.44E-03	1.11E-02

2 MeV Poly-Pb Dose (Fractional Difference)

Full	1	2	3	4	5	6	7	8	9	10
1	1.47E-01	1.13E-01	8.54E-02	6.22E-02	4.29E-02	2.72E-02	1.51E-02	6.42E-03	1.26E-03	-3.89E-04
2	1.51E-02	2.15E-02	1.75E-02	1.05E-02	3.06E-03	-3.31E-03	-7.90E-03	-1.02E-02	-9.87E-03	-6.51E-03
3	-4.03E-02	-1.84E-02	-1.23E-02	-1.20E-02	-1.37E-02	-1.53E-02	-1.58E-02	-1.45E-02	-1.08E-02	-4.25E-03
4	-5.54E-02	-2.81E-02	-1.88E-02	-1.61E-02	-1.57E-02	-1.54E-02	-1.42E-02	-1.14E-02	-5.60E-03	2.58E-03
5	-4.95E-02	-2.12E-02	-1.23E-02	-9.99E-03	-9.40E-03	-9.31E-03	-7.56E-03	-4.32E-03	1.46E-03	1.08E-02
6	-3.44E-02	-7.24E-03	-2.44E-04	3.23E-04	-4.62E-04	-1.44E-03	-4.80E-04	2.19E-03	7.59E-03	1.67E-02
7	-1.84E-02	6.87E-03	1.14E-02	9.70E-03	6.99E-03	4.39E-03	3.99E-03	5.50E-03	9.90E-03	1.81E-02
8	-7.08E-03	1.64E-02	1.86E-02	1.47E-02	9.96E-03	5.56E-03	3.56E-03	3.61E-03	6.65E-03	1.35E-02
9	-3.46E-03	1.88E-02	1.91E-02	1.32E-02	6.70E-03	6.28E-04	-2.97E-03	-4.47E-03	-2.98E-03	2.33E-03
10	-8.65E-03	1.28E-02	1.19E-02	4.63E-03	-3.31E-03	-1.08E-02	-1.58E-02	-1.88E-02	-1.89E-02	-1.53E-02

Low	1	2	3	4	5	6	7	8	9	10
1	5.12E-02	3.58E-02	2.41E-02	1.48E-02	7.35E-03	1.66E-03	-2.37E-03	-4.71E-03	-5.15E-03	-3.69E-03
2	-2.45E-02	-1.18E-02	-7.87E-03	-6.89E-03	-6.88E-03	-6.80E-03	-6.08E-03	-4.34E-03	-1.19E-03	3.57E-03
3	-3.27E-02	-1.30E-02	-6.26E-03	-3.86E-03	-3.06E-03	-2.40E-03	-1.19E-03	1.00E-03	4.64E-03	9.89E-03
4	-1.78E-02	1.58E-03	5.99E-03	5.71E-03	4.00E-03	2.39E-03	1.58E-03	1.79E-03	4.09E-03	7.70E-03
5	-3.94E-03	1.34E-02	1.38E-02	9.39E-03	4.32E-03	-8.87E-04	-4.53E-03	-7.17E-03	-8.09E-03	-6.61E-03

High	1	2	3	4	5	6	7	8	9	10
6	-3.21E-03	1.14E-02	9.46E-03	3.88E-03	-1.08E-03	-4.93E-03	-6.04E-03	-5.02E-03	-1.14E-03	6.30E-03
7	-1.27E-02	6.38E-03	6.89E-03	2.76E-03	-1.36E-03	-4.79E-03	-5.76E-03	-4.80E-03	-1.15E-03	5.92E-03
8	-1.63E-02	5.89E-03	7.98E-03	4.59E-03	7.03E-04	-2.83E-03	-4.14E-03	-3.70E-03	-7.25E-04	5.52E-03
9	-1.78E-02	6.88E-03	1.00E-02	6.99E-03	2.98E-03	-9.53E-04	-2.88E-03	-3.25E-03	-1.24E-03	3.90E-03
10	-1.93E-02	7.32E-03	1.13E-02	8.34E-03	4.06E-03	-4.31E-04	-3.13E-03	-4.45E-03	-3.56E-03	2.92E-04

6 MeV Poly-Pb Dose (Fractional Difference)

Full	1	2	3	4	5	6	7	8	9	10
1	1.33E-01	1.40E-01	1.41E-01	1.36E-01	1.26E-01	1.12E-01	9.52E-02	7.72E-02	5.81E-02	3.86E-02
2	3.89E-03	2.38E-02	3.41E-02	3.70E-02	3.44E-02	2.80E-02	1.88E-02	7.74E-03	-4.41E-03	-1.70E-02
3	-5.19E-02	-2.90E-02	-1.53E-02	-8.97E-03	-7.75E-03	-1.02E-02	-1.51E-02	-2.13E-02	-2.88E-02	-3.64E-02
4	-6.91E-02	-4.65E-02	-3.21E-02	-2.45E-02	-2.13E-02	-2.13E-02	-2.33E-02	-2.62E-02	-2.99E-02	-3.34E-02
5	-6.38E-02	-4.32E-02	-2.97E-02	-2.21E-02	-1.82E-02	-1.67E-02	-1.68E-02	-1.71E-02	-1.77E-02	-1.75E-02
6	-4.56E-02	-2.84E-02	-1.71E-02	-1.06E-02	-6.87E-03	-4.95E-03	-3.86E-03	-2.36E-03	-5.40E-04	2.79E-03
7	-2.22E-02	-9.60E-03	-1.53E-03	2.87E-03	5.31E-03	6.75E-03	8.50E-03	1.05E-02	1.38E-02	1.94E-02
8	2.66E-04	7.31E-03	1.12E-02	1.24E-02	1.26E-02	1.26E-02	1.35E-02	1.52E-02	1.89E-02	2.54E-02
9	1.61E-02	1.65E-02	1.51E-02	1.22E-02	9.01E-03	6.31E-03	5.11E-03	5.20E-03	7.67E-03	1.33E-02
10	2.17E-02	1.49E-02	7.49E-03	-4.11E-04	-7.77E-03	-1.41E-02	-1.90E-02	-2.14E-02	-2.16E-02	-1.86E-02

Low	1	2	3	4	5	6	7	8	9	10
1	2.66E-02	3.39E-02	3.74E-02	3.69E-02	3.30E-02	2.66E-02	1.85E-02	9.29E-03	-5.30E-04	-1.04E-02
2	-3.71E-02	-2.15E-02	-1.15E-02	-6.10E-03	-3.98E-03	-4.18E-03	-5.91E-03	-8.44E-03	-1.12E-02	-1.37E-02
3	-3.68E-02	-2.33E-02	-1.39E-02	-8.43E-03	-5.24E-03	-3.51E-03	-2.53E-03	-1.19E-03	2.44E-04	2.82E-03
4	-1.05E-02	-4.13E-03	-3.30E-05	1.82E-03	2.66E-03	3.16E-03	3.89E-03	5.85E-03	8.76E-03	1.37E-02
5	1.77E-02	1.37E-02	9.49E-03	4.72E-03	2.62E-04	-3.48E-03	-6.10E-03	-6.77E-03	-5.84E-03	-2.34E-03

High	1	2	3	4	5	6	7	8	9	10
6	-1.65E-03	1.59E-03	4.22E-03	5.51E-03	5.97E-03	5.57E-03	4.33E-03	2.65E-03	-3.48E-04	-4.26E-03
7	-7.75E-03	-5.49E-03	-3.28E-03	-1.88E-03	-8.67E-04	-3.03E-04	2.11E-04	-2.44E-04	-1.28E-03	-2.94E-03
8	-5.31E-03	-4.71E-03	-3.58E-03	-2.74E-03	-1.82E-03	-9.46E-04	2.43E-04	8.12E-04	1.11E-03	1.08E-03
9	1.78E-03	-1.03E-04	-8.31E-04	-1.31E-03	-1.26E-03	-8.29E-04	2.71E-04	1.09E-03	1.95E-03	2.76E-03
10	1.10E-02	6.01E-03	2.76E-03	2.80E-04	-1.23E-03	-1.99E-03	-2.18E-03	-1.49E-03	-9.15E-04	-1.31E-04

10 MeV Poly-Pb Dose (Fractional Difference)

Full	1	2	3	4	5	6	7	8	9	10
1	1.01E-01	1.26E-01	1.48E-01	1.62E-01	1.66E-01	1.60E-01	1.47E-01	1.25E-01	9.63E-02	6.09E-02
2	-2.01E-02	7.07E-03	2.89E-02	4.33E-02	4.95E-02	4.82E-02	3.92E-02	2.43E-02	3.35E-03	-2.31E-02
3	-7.23E-02	-4.74E-02	-2.69E-02	-1.25E-02	-4.76E-03	-3.20E-03	-7.79E-03	-1.71E-02	-3.13E-02	-5.00E-02
4	-8.75E-02	-6.63E-02	-4.79E-02	-3.41E-02	-2.54E-02	-2.15E-02	-2.23E-02	-2.65E-02	-3.43E-02	-4.53E-02
5	-8.00E-02	-6.36E-02	-4.81E-02	-3.56E-02	-2.67E-02	-2.11E-02	-1.88E-02	-1.85E-02	-2.03E-02	-2.38E-02
6	-5.84E-02	-4.76E-02	-3.60E-02	-2.58E-02	-1.77E-02	-1.16E-02	-7.37E-03	-3.62E-03	-3.20E-04	2.89E-03
7	-2.85E-02	-2.45E-02	-1.80E-02	-1.13E-02	-5.45E-03	-2.81E-04	4.25E-03	9.63E-03	1.60E-02	2.39E-02
8	5.02E-03	9.03E-04	1.17E-03	2.84E-03	4.79E-03	7.09E-03	9.70E-03	1.41E-02	2.06E-02	2.96E-02
9	3.81E-02	2.48E-02	1.74E-02	1.26E-02	8.89E-03	6.24E-03	4.47E-03	4.99E-03	7.88E-03	1.37E-02
10	6.77E-02	4.43E-02	2.81E-02	1.54E-02	4.39E-03	-5.12E-03	-1.35E-02	-1.96E-02	-2.36E-02	-2.50E-02

Low	1	2	3	4	5	6	7	8	9	10
1	9.54E-03	2.07E-02	3.37E-02	4.29E-02	4.69E-02	4.56E-02	3.91E-02	2.76E-02	1.14E-02	-9.57E-03
2	-4.81E-02	-3.61E-02	-2.34E-02	-1.31E-02	-6.30E-03	-3.14E-03	-3.83E-03	-7.19E-03	-1.35E-02	-2.25E-02
3	-4.08E-02	-3.49E-02	-2.65E-02	-1.85E-02	-1.22E-02	-7.60E-03	-4.84E-03	-2.66E-03	-1.18E-03	-1.20E-04
4	-3.06E-03	-7.31E-03	-6.69E-03	-4.59E-03	-2.35E-03	-5.78E-05	2.11E-03	5.51E-03	1.02E-02	1.66E-02
5	4.49E-02	2.71E-02	1.64E-02	8.97E-03	3.04E-03	-1.64E-03	-5.41E-03	-7.03E-03	-6.53E-03	-3.45E-03

High	1	2	3	4	5	6	7	8	9	10
6	-1.11E-02	-7.25E-03	-1.01E-03	4.67E-03	8.47E-03	1.02E-02	9.37E-03	6.82E-03	1.91E-03	-5.83E-03
7	-1.24E-02	-1.22E-02	-8.54E-03	-4.41E-03	-1.19E-03	9.19E-04	1.43E-03	1.23E-03	-3.04E-04	-3.62E-03
8	-4.23E-03	-8.34E-03	-7.80E-03	-5.85E-03	-3.89E-03	-2.18E-03	-1.19E-03	1.89E-05	8.43E-04	8.97E-04
9	1.04E-02	1.42E-03	-1.80E-03	-2.69E-03	-2.78E-03	-2.34E-03	-1.88E-03	-4.26E-04	1.45E-03	3.42E-03
10	2.93E-02	1.48E-02	7.21E-03	2.75E-03	-2.05E-04	-2.02E-03	-3.22E-03	-2.86E-03	-1.48E-03	5.77E-04

Lead Followed by Polyethylene

65 keV Pb-Poly Dose (Fractional Difference)

Full	1	2	3	4	5	6	7	8	9	10
1	-6.93E-01	-1.30E-01	2.10E-02	5.56E-02	5.65E-02	4.98E-02	4.29E-02	3.47E-02	1.93E-02	-1.34E-02
2	-6.59E-01	-1.47E-01	-1.02E-02	2.19E-02	2.46E-02	2.18E-02	2.01E-02	1.84E-02	1.03E-02	-1.52E-02
3	-5.96E-01	-1.42E-01	-2.43E-02	1.56E-03	3.44E-03	2.47E-03	4.44E-03	7.91E-03	5.98E-03	-1.30E-02
4	-5.07E-01	-1.19E-01	-2.49E-02	-8.28E-03	-9.44E-03	-1.03E-02	-6.02E-03	1.39E-03	4.68E-03	-8.71E-03
5	-3.97E-01	-8.03E-02	-1.44E-02	-9.57E-03	-1.57E-02	-1.78E-02	-1.26E-02	-2.37E-03	5.10E-03	-3.50E-03
6	-2.69E-01	-2.95E-02	5.39E-03	-3.76E-03	-1.64E-02	-2.12E-02	-1.62E-02	-4.34E-03	6.23E-03	1.47E-03
7	-1.26E-01	3.18E-02	3.29E-02	7.82E-03	-1.28E-02	-2.14E-02	-1.78E-02	-5.47E-03	7.01E-03	4.99E-03
8	2.94E-02	1.02E-01	6.68E-02	2.42E-02	-5.66E-03	-1.93E-02	-1.81E-02	-6.47E-03	6.68E-03	6.15E-03
9	1.95E-01	1.79E-01	1.06E-01	4.42E-02	4.05E-03	-1.56E-02	-1.79E-02	-8.11E-03	4.37E-03	4.02E-03
10	3.69E-01	2.62E-01	1.49E-01	6.71E-02	1.56E-02	-1.09E-02	-1.77E-02	-1.10E-02	-4.67E-04	-2.04E-03

Low	1	2	3	4	5	6	7	8	9	10
1	-4.81E-01	-7.31E-02	1.88E-02	2.95E-02	2.17E-02	1.40E-02	1.14E-02	1.21E-02	9.33E-03	-8.49E-03
2	-4.10E-01	-6.55E-02	5.64E-03	9.55E-03	4.94E-04	-5.40E-03	-4.27E-03	1.83E-03	5.81E-03	-4.67E-03
3	-2.83E-01	-2.11E-02	1.81E-02	8.36E-03	-6.46E-03	-1.41E-02	-1.21E-02	-3.25E-03	5.12E-03	-1.40E-04
4	-1.08E-01	5.29E-02	5.09E-02	2.20E-02	-2.51E-03	-1.49E-02	-1.47E-02	-5.56E-03	4.71E-03	2.33E-03
5	1.04E-01	1.51E-01	1.00E-01	4.72E-02	9.83E-03	-9.93E-03	-1.40E-02	-6.98E-03	2.60E-03	5.49E-04

High	1	2	3	4	5	6	7	8	9	10
6	-4.44E-01	-7.53E-02	7.09E-03	1.61E-02	9.10E-03	3.29E-03	3.11E-03	6.78E-03	7.64E-03	-5.74E-03
7	-3.40E-01	-3.86E-02	1.76E-02	1.53E-02	3.28E-03	-4.13E-03	-3.84E-03	1.88E-03	6.01E-03	-3.49E-03
8	-2.26E-01	5.79E-03	3.40E-02	1.90E-02	1.16E-03	-8.67E-03	-8.66E-03	-1.62E-03	5.09E-03	-1.13E-03
9	-1.04E-01	5.66E-02	5.53E-02	2.67E-02	2.04E-03	-1.10E-02	-1.20E-02	-4.32E-03	4.23E-03	6.01E-04
10	2.56E-02	1.13E-01	8.07E-02	3.75E-02	5.36E-03	-1.15E-02	-1.42E-02	-6.68E-03	2.93E-03	1.15E-03

100 keV Pb-Poly Dose (Fractional Difference)

Full	1	2	3	4	5	6	7	8	9	10
1	3.29E-01	1.49E-01	6.24E-02	2.49E-02	9.34E-03	6.82E-04	-9.73E-03	-2.71E-02	-5.41E-02	-9.16E-02
2	1.37E-01	3.22E-02	-1.27E-02	-2.15E-02	-1.46E-02	-4.67E-03	2.88E-04	-4.74E-03	-2.24E-02	-5.35E-02
3	2.39E-02	-3.91E-02	-5.74E-02	-4.61E-02	-2.22E-02	2.68E-03	2.05E-02	2.60E-02	1.64E-02	-9.11E-03
4	-4.05E-02	-8.04E-02	-8.22E-02	-5.74E-02	-2.15E-02	1.43E-02	4.19E-02	5.56E-02	5.25E-02	3.13E-02
5	-6.93E-02	-9.87E-02	-9.22E-02	-6.03E-02	-1.78E-02	2.40E-02	5.69E-02	7.53E-02	7.56E-02	5.68E-02
6	-6.87E-02	-9.74E-02	-8.97E-02	-5.68E-02	-1.38E-02	2.82E-02	6.09E-02	7.88E-02	7.84E-02	5.87E-02
7	-4.10E-02	-7.73E-02	-7.51E-02	-4.74E-02	-9.85E-03	2.62E-02	5.27E-02	6.44E-02	5.84E-02	3.39E-02
8	1.37E-02	-3.83E-02	-4.78E-02	-3.11E-02	-4.77E-03	1.96E-02	3.44E-02	3.48E-02	1.87E-02	-1.42E-02
9	9.69E-02	2.06E-02	-7.35E-03	-7.10E-03	2.86E-03	1.08E-02	9.48E-03	-5.19E-03	-3.47E-02	-7.83E-02
10	2.11E-01	1.00E-01	4.66E-02	2.48E-02	1.38E-02	1.51E-03	-1.90E-02	-5.11E-02	-9.53E-02	-1.51E-01

Low	1	2	3	4	5	6	7	8	9	10
1	6.74E-02	4.29E-02	2.73E-02	1.88E-02	1.19E-02	4.33E-03	-4.53E-03	-1.44E-02	-2.48E-02	-3.52E-02
2	-3.50E-02	-2.26E-02	-1.57E-02	-7.40E-03	-4.80E-04	3.57E-03	4.70E-03	3.36E-03	2.79E-04	-3.81E-03
3	-5.46E-02	-3.44E-02	-2.31E-02	-1.06E-02	7.12E-04	9.41E-03	1.52E-02	1.85E-02	1.99E-02	2.01E-02
4	-1.78E-02	-1.17E-02	-1.09E-02	-5.67E-03	1.18E-03	7.51E-03	1.26E-02	1.64E-02	1.92E-02	2.14E-02
5	5.89E-02	3.03E-02	6.33E-03	-6.18E-03	-1.21E-02	-1.48E-02	-1.58E-02	-1.58E-02	-1.52E-02	-1.38E-02

High	1	2	3	4	5	6	7	8	9	10
6	-4.13E-02	-4.27E-02	-3.31E-02	-1.51E-02	5.41E-03	2.53E-02	4.27E-02	5.69E-02	6.76E-02	7.47E-02
7	-9.97E-02	-7.66E-02	-4.85E-02	-1.66E-02	1.50E-02	4.37E-02	6.86E-02	8.93E-02	1.06E-01	1.18E-01
8	-1.32E-01	-9.30E-02	-5.41E-02	-1.56E-02	1.96E-02	5.02E-02	7.57E-02	9.63E-02	1.12E-01	1.24E-01
9	-1.33E-01	-8.55E-02	-4.36E-02	-6.13E-03	2.52E-02	5.01E-02	6.90E-02	8.27E-02	9.20E-02	9.76E-02
10	-9.50E-02	-4.73E-02	-1.10E-02	1.66E-02	3.59E-02	4.75E-02	5.30E-02	5.37E-02	5.07E-02	4.50E-02

500 keV Pb-Poly Dose (Fractional Difference)

Full	1	2	3	4	5	6	7	8	9	10
1	-1.14E-01	4.16E-02	9.06E-02	9.93E-02	9.20E-02	7.80E-02	6.06E-02	4.03E-02	1.66E-02	-1.17E-02
2	-1.72E-01	-2.69E-02	2.39E-02	3.88E-02	3.94E-02	3.39E-02	2.51E-02	1.33E-02	-2.67E-03	-2.40E-02
3	-1.85E-01	-5.80E-02	-1.14E-02	4.82E-03	9.37E-03	9.18E-03	6.36E-03	6.68E-04	-9.21E-03	-2.51E-02
4	-1.72E-01	-6.59E-02	-2.72E-02	-1.27E-02	-6.66E-03	-3.60E-03	-2.14E-03	-2.99E-03	-7.89E-03	-1.91E-02
5	-1.39E-01	-5.80E-02	-2.98E-02	-1.92E-02	-1.36E-02	-8.85E-03	-4.40E-03	-1.49E-03	-2.36E-03	-9.60E-03
6	-9.21E-02	-3.88E-02	-2.34E-02	-1.85E-02	-1.48E-02	-9.74E-03	-3.47E-03	2.20E-03	4.58E-03	5.79E-04
7	-3.57E-02	-1.18E-02	-1.08E-02	-1.32E-02	-1.29E-02	-8.78E-03	-1.87E-03	5.49E-03	1.02E-02	8.61E-03
8	2.69E-02	2.01E-02	5.08E-03	-5.92E-03	-1.02E-02	-8.26E-03	-1.94E-03	5.92E-03	1.18E-02	1.16E-02
9	9.29E-02	5.41E-02	2.22E-02	1.43E-03	-8.65E-03	-1.01E-02	-5.59E-03	1.47E-03	7.29E-03	7.44E-03
10	1.59E-01	8.82E-02	3.85E-02	7.15E-03	-9.72E-03	-1.57E-02	-1.43E-02	-9.40E-03	-5.07E-03	-5.74E-03

Low	1	2	3	4	5	6	7	8	9	10
1	-1.02E-01	-4.93E-04	2.96E-02	3.48E-02	3.17E-02	2.63E-02	2.01E-02	1.25E-02	1.82E-03	-1.40E-02
2	-1.19E-01	-3.59E-02	-9.74E-03	-2.55E-03	-6.67E-04	5.19E-04	1.81E-03	2.15E-03	-5.54E-04	-8.89E-03
3	-7.76E-02	-2.65E-02	-1.43E-02	-1.24E-02	-1.14E-02	-8.51E-03	-3.75E-03	1.15E-03	3.56E-03	3.00E-04
4	6.04E-04	1.03E-02	1.97E-03	-6.76E-03	-1.10E-02	-9.99E-03	-5.10E-03	1.32E-03	6.17E-03	5.67E-03
5	1.01E-01	6.34E-02	2.98E-02	6.61E-03	-6.22E-03	-1.04E-02	-8.46E-03	-3.50E-03	8.42E-04	6.05E-04

High	1	2	3	4	5	6	7	8	9	10
6	-9.58E-02	-1.79E-02	5.23E-03	1.02E-02	9.96E-03	8.95E-03	7.99E-03	6.18E-03	1.72E-03	-7.51E-03
7	-6.86E-02	-1.22E-02	1.47E-03	2.54E-03	1.37E-03	1.19E-03	2.17E-03	3.00E-03	1.54E-03	-4.68E-03
8	-3.36E-02	2.31E-04	3.27E-03	-5.35E-04	-3.51E-03	-3.63E-03	-1.39E-03	1.46E-03	2.51E-03	-1.22E-03
9	7.13E-03	1.74E-02	8.96E-03	-5.71E-04	-6.12E-03	-6.91E-03	-4.09E-03	1.68E-04	3.14E-03	1.52E-03
10	5.18E-02	3.79E-02	1.72E-02	1.16E-03	-7.68E-03	-9.85E-03	-7.16E-03	-2.16E-03	2.03E-03	2.04E-03

1 MeV Pb-Poly Dose (Fractional Difference)

Full	1	2	3	4	5	6	7	8	9	10
1	6.26E-02	1.16E-01	1.21E-01	1.09E-01	8.97E-02	6.87E-02	4.71E-02	2.60E-02	5.29E-03	-1.47E-02
2	-4.48E-02	2.14E-02	4.12E-02	4.29E-02	3.68E-02	2.68E-02	1.51E-02	2.35E-03	-1.10E-02	-2.45E-02
3	-9.00E-02	-2.52E-02	-7.55E-04	7.42E-03	8.08E-03	4.85E-03	-6.27E-04	-7.58E-03	-1.57E-02	-2.46E-02
4	-1.01E-01	-4.39E-02	-2.00E-02	-9.43E-03	-5.18E-03	-4.37E-03	-5.70E-03	-8.60E-03	-1.28E-02	-1.81E-02
5	-9.10E-02	-4.50E-02	-2.47E-02	-1.44E-02	-8.70E-03	-5.59E-03	-4.22E-03	-4.27E-03	-5.65E-03	-8.21E-03
6	-6.65E-02	-3.49E-02	-2.06E-02	-1.23E-02	-6.75E-03	-2.67E-03	2.76E-04	2.15E-03	2.82E-03	2.34E-03
7	-3.33E-02	-1.82E-02	-1.17E-02	-7.13E-03	-2.97E-03	1.01E-03	4.58E-03	7.54E-03	9.56E-03	1.05E-02
8	4.12E-03	8.58E-04	-1.92E-03	-2.25E-03	-5.76E-04	2.30E-03	5.64E-03	8.92E-03	1.16E-02	1.35E-02
9	4.16E-02	1.88E-02	5.60E-03	-6.29E-04	-2.39E-03	-1.48E-03	8.74E-04	3.75E-03	6.44E-03	8.55E-03
10	7.53E-02	3.23E-02	8.06E-03	-4.80E-03	-1.08E-02	-1.26E-02	-1.20E-02	-1.02E-02	-8.14E-03	-6.35E-03

Low	1	2	3	4	5	6	7	8	9	10
1	-1.49E-02	2.89E-02	3.94E-02	3.78E-02	3.16E-02	2.35E-02	1.44E-02	4.78E-03	-5.51E-03	-1.65E-02
2	-6.83E-02	-2.48E-02	-7.95E-03	-9.54E-04	1.84E-03	2.48E-03	1.69E-03	-3.13E-04	-3.68E-03	-8.48E-03
3	-5.29E-02	-2.83E-02	-1.78E-02	-1.16E-02	-6.95E-03	-3.07E-03	5.24E-05	2.15E-03	2.86E-03	1.98E-03
4	-1.11E-03	-5.26E-03	-8.36E-03	-8.65E-03	-6.73E-03	-3.50E-03	2.16E-04	3.65E-03	6.12E-03	7.19E-03
5	6.79E-02	2.94E-02	8.25E-03	-2.35E-03	-6.51E-03	-6.86E-03	-5.16E-03	-2.73E-03	-5.77E-04	6.07E-04

High	1	2	3	4	5	6	7	8	9	10
6	-2.59E-02	-9.13E-04	6.90E-03	8.93E-03	8.65E-03	7.19E-03	4.92E-03	1.93E-03	-1.85E-03	-6.36E-03
7	-2.24E-02	-5.34E-03	-2.10E-04	1.49E-03	2.06E-03	2.11E-03	1.65E-03	6.42E-04	-1.12E-03	-3.64E-03
8	-1.11E-02	-3.36E-03	-2.13E-03	-1.75E-03	-1.14E-03	-3.18E-04	4.31E-04	8.72E-04	6.67E-04	-2.74E-04
9	5.33E-03	2.56E-03	-1.05E-03	-2.82E-03	-2.88E-03	-1.88E-03	-4.18E-04	9.97E-04	1.94E-03	2.21E-03
10	2.46E-02	1.02E-02	9.35E-04	-3.65E-03	-5.00E-03	-4.39E-03	-2.74E-03	-7.89E-04	8.94E-04	2.03E-03

2 MeV Pb-Poly Dose (Fractional Difference)

Full	1	2	3	4	5	6	7	8	9	10
1	1.15E-01	1.16E-01	1.03E-01	8.35E-02	6.24E-02	4.14E-02	2.16E-02	3.53E-03	-1.25E-02	-2.65E-02
2	5.81E-04	2.86E-02	3.69E-02	3.48E-02	2.71E-02	1.67E-02	5.40E-03	-5.73E-03	-1.61E-02	-2.53E-02
3	-5.18E-02	-1.67E-02	6.43E-04	7.29E-03	7.40E-03	3.76E-03	-1.78E-03	-8.01E-03	-1.42E-02	-1.98E-02
4	-6.93E-02	-3.63E-02	-1.64E-02	-5.81E-03	-1.42E-03	-9.53E-04	-2.71E-03	-5.54E-03	-8.66E-03	-1.15E-02
5	-6.49E-02	-3.91E-02	-2.08E-02	-9.39E-03	-3.14E-03	-4.32E-04	1.06E-04	-4.89E-04	-1.44E-03	-2.24E-03
6	-4.64E-02	-3.13E-02	-1.74E-02	-7.39E-03	-1.08E-03	2.42E-03	4.14E-03	4.91E-03	5.38E-03	6.04E-03
7	-2.00E-02	-1.81E-02	-1.04E-02	-3.35E-03	1.78E-03	5.06E-03	7.11E-03	8.56E-03	9.90E-03	1.16E-02
8	8.72E-03	-3.84E-03	-3.67E-03	-5.92E-04	2.47E-03	4.81E-03	6.63E-03	8.26E-03	1.01E-02	1.23E-02
9	3.50E-02	7.48E-03	-3.36E-04	-1.75E-03	-1.27E-03	-2.87E-04	9.06E-04	2.39E-03	4.36E-03	7.00E-03
10	5.44E-02	1.25E-02	-3.20E-03	-9.20E-03	-1.14E-02	-1.19E-02	-1.15E-02	-1.04E-02	-8.40E-03	-5.56E-03

Low	1	2	3	4	5	6	7	8	9	10
1	2.12E-02	3.16E-02	3.24E-02	2.80E-02	2.11E-02	1.32E-02	5.30E-03	-2.20E-03	-9.00E-03	-1.50E-02
2	-3.98E-02	-1.90E-02	-6.57E-03	-1.60E-04	2.28E-03	2.29E-03	9.99E-04	-8.78E-04	-2.87E-03	-4.69E-03
3	-3.50E-02	-2.54E-02	-1.52E-02	-7.54E-03	-2.58E-03	3.72E-04	2.03E-03	2.97E-03	3.60E-03	4.20E-03
4	1.17E-03	-9.84E-03	-9.06E-03	-5.70E-03	-2.45E-03	1.35E-04	2.15E-03	3.80E-03	5.33E-03	6.94E-03
5	4.74E-02	1.21E-02	1.76E-04	-3.66E-03	-4.58E-03	-4.43E-03	-3.84E-03	-2.95E-03	-1.75E-03	-2.15E-04

High	1	2	3	4	5	6	7	8	9	10
6	-6.80E-03	7.82E-04	6.69E-03	9.10E-03	8.46E-03	5.85E-03	2.29E-03	-1.42E-03	-4.66E-03	-7.03E-03
7	-1.02E-02	-5.82E-03	-3.79E-04	2.87E-03	3.71E-03	2.83E-03	1.09E-03	-7.65E-04	-2.20E-03	-2.80E-03
8	-5.48E-03	-6.30E-03	-2.85E-03	-1.97E-05	1.29E-03	1.33E-03	7.75E-04	2.28E-04	1.69E-04	9.83E-04
9	4.26E-03	-3.22E-03	-2.89E-03	-1.35E-03	-3.61E-04	-4.85E-06	1.13E-04	4.62E-04	1.44E-03	3.38E-03
10	1.61E-02	8.38E-04	-2.75E-03	-3.17E-03	-2.95E-03	-2.71E-03	-2.28E-03	-1.33E-03	4.17E-04	3.25E-03

6 MeV Pb-Poly Dose (Fractional Difference)

Full	1	2	3	4	5	6	7	8	9	10
1	7.02E-03	4.59E-02	4.37E-02	3.03E-02	1.61E-02	4.84E-03	-1.82E-03	-3.24E-03	8.76E-04	1.08E-02
2	-4.14E-02	9.54E-03	1.68E-02	9.92E-03	3.08E-04	-7.44E-03	-1.14E-02	-1.07E-02	-4.77E-03	6.72E-03
3	-5.01E-02	-2.63E-03	6.25E-03	1.41E-03	-6.44E-03	-1.27E-02	-1.55E-02	-1.37E-02	-6.92E-03	5.32E-03
4	-3.87E-02	-4.05E-04	6.29E-03	9.86E-04	-6.84E-03	-1.29E-02	-1.55E-02	-1.35E-02	-6.58E-03	5.79E-03
5	-2.07E-02	8.14E-03	1.17E-02	5.09E-03	-3.48E-03	-1.01E-02	-1.30E-02	-1.14E-02	-4.74E-03	7.31E-03
6	-5.28E-03	1.67E-02	1.82E-02	1.05E-02	1.24E-03	-5.98E-03	-9.48E-03	-8.40E-03	-2.35E-03	9.09E-03
7	1.95E-03	2.09E-02	2.23E-02	1.47E-02	5.30E-03	-2.22E-03	-6.15E-03	-5.63E-03	-2.34E-04	1.04E-02
8	-1.70E-03	1.82E-02	2.18E-02	1.58E-02	7.20E-03	-4.45E-05	-4.09E-03	-3.95E-03	8.86E-04	1.08E-02
9	-1.68E-02	7.21E-03	1.52E-02	1.23E-02	5.69E-03	-5.25E-04	-4.18E-03	-4.07E-03	3.85E-04	9.68E-03
10	-4.23E-02	-1.20E-02	2.14E-03	3.83E-03	1.89E-04	-4.21E-03	-6.90E-03	-6.44E-03	-2.08E-03	6.75E-03

Low	1	2	3	4	5	6	7	8	9	10
1	3.49E-02	1.62E-02	6.58E-03	1.25E-03	-1.72E-03	-3.10E-03	-3.30E-03	-2.49E-03	-8.24E-04	1.65E-03
2	-9.22E-03	-5.63E-03	-4.85E-03	-4.83E-03	-4.70E-03	-4.09E-03	-2.92E-03	-1.10E-03	1.32E-03	4.40E-03
3	-1.73E-02	-5.79E-03	-1.87E-03	-1.09E-03	-1.15E-03	-1.08E-03	-5.67E-04	5.87E-04	2.38E-03	4.88E-03
4	-1.32E-02	1.36E-03	5.75E-03	5.42E-03	3.65E-03	1.88E-03	6.27E-04	1.59E-04	4.86E-04	1.65E-03
5	-1.19E-02	5.45E-03	1.04E-02	9.07E-03	5.50E-03	1.69E-03	-1.60E-03	-4.01E-03	-5.49E-03	-5.98E-03

High	1	2	3	4	5	6	7	8	9	10
6	-2.50E-02	1.05E-02	1.70E-02	1.11E-02	2.25E-03	-5.03E-03	-8.68E-03	-7.67E-03	-1.49E-03	1.03E-02
7	-1.41E-02	1.13E-02	1.52E-02	8.72E-03	-1.93E-04	-7.40E-03	-1.10E-02	-1.00E-02	-3.97E-03	7.57E-03
8	-8.24E-03	1.15E-02	1.47E-02	8.45E-03	-1.13E-04	-7.11E-03	-1.07E-02	-9.79E-03	-3.96E-03	7.26E-03
9	-9.35E-03	8.83E-03	1.33E-02	8.52E-03	9.58E-04	-5.46E-03	-8.77E-03	-7.88E-03	-2.25E-03	8.63E-03
10	-1.79E-02	2.12E-03	9.86E-03	7.72E-03	1.96E-03	-3.36E-03	-6.10E-03	-5.00E-03	5.80E-04	1.12E-02

10 MeV Pb-Poly Dose (Fractional Difference)

Full	1	2	3	4	5	6	7	8	9	10
1	-3.18E-02	8.96E-02	7.42E-02	4.11E-02	1.20E-02	-8.71E-03	-2.03E-02	-2.29E-02	-1.67E-02	-1.61E-03
2	-6.07E-02	6.44E-02	5.72E-02	2.96E-02	4.09E-03	-1.40E-02	-2.35E-02	-2.45E-02	-1.69E-02	-4.78E-04
3	-6.61E-02	4.85E-02	4.55E-02	2.17E-02	-1.03E-03	-1.70E-02	-2.49E-02	-2.44E-02	-1.56E-02	1.88E-03
4	-5.65E-02	3.91E-02	3.77E-02	1.66E-02	-3.86E-03	-1.81E-02	-2.46E-02	-2.30E-02	-1.31E-02	5.39E-03
5	-3.90E-02	3.35E-02	3.24E-02	1.35E-02	-4.99E-03	-1.77E-02	-2.30E-02	-2.03E-02	-9.51E-03	9.87E-03
6	-1.94E-02	2.93E-02	2.82E-02	1.16E-02	-4.99E-03	-1.62E-02	-2.03E-02	-1.67E-02	-5.03E-03	1.52E-02
7	-3.25E-03	2.38E-02	2.36E-02	9.78E-03	-4.59E-03	-1.42E-02	-1.71E-02	-1.25E-02	5.13E-05	2.10E-02
8	5.46E-03	1.51E-02	1.74E-02	7.30E-03	-4.29E-03	-1.19E-02	-1.34E-02	-7.76E-03	5.63E-03	2.74E-02
9	3.58E-03	1.58E-03	8.36E-03	3.20E-03	-4.84E-03	-1.01E-02	-9.89E-03	-2.98E-03	1.14E-02	3.40E-02
10	-1.08E-02	-1.82E-02	-4.66E-03	-3.39E-03	-6.92E-03	-9.13E-03	-6.87E-03	1.51E-03	1.70E-02	4.05E-02

Low	1	2	3	4	5	6	7	8	9	10
1	3.23E-02	1.54E-02	2.16E-03	-5.81E-03	-9.71E-03	-1.04E-02	-8.23E-03	-3.54E-03	3.52E-03	1.29E-02
2	-8.23E-03	5.01E-03	7.09E-04	-4.84E-03	-8.45E-03	-9.54E-03	-8.11E-03	-4.20E-03	2.04E-03	1.06E-02
3	-2.35E-02	1.04E-02	1.11E-02	5.03E-03	-7.23E-04	-4.35E-03	-5.44E-03	-3.91E-03	1.22E-04	6.58E-03
4	-3.66E-02	1.67E-02	2.30E-02	1.65E-02	8.15E-03	1.38E-03	-2.91E-03	-4.47E-03	-3.37E-03	3.00E-04
5	-6.03E-02	1.38E-02	2.86E-02	2.36E-02	1.39E-02	4.55E-03	-2.68E-03	-7.28E-03	-9.18E-03	-8.44E-03

High	1	2	3	4	5	6	7	8	9	10
6	-3.36E-02	3.26E-02	3.80E-02	2.34E-02	6.79E-03	-5.62E-03	-1.17E-02	-1.08E-02	-2.52E-03	1.35E-02
7	-1.35E-02	1.92E-02	2.40E-02	1.23E-02	-1.80E-03	-1.24E-02	-1.72E-02	-1.53E-02	-6.38E-03	1.00E-02
8	-7.02E-04	9.97E-03	1.54E-02	6.53E-03	-5.29E-03	-1.43E-02	-1.80E-02	-1.54E-02	-6.03E-03	1.06E-02
9	3.53E-03	1.73E-03	9.68E-03	4.37E-03	-4.93E-03	-1.23E-02	-1.50E-02	-1.18E-02	-1.99E-03	1.50E-02
10	-8.82E-04	-7.68E-03	5.03E-03	4.36E-03	-1.83E-03	-7.29E-03	-8.84E-03	-4.91E-03	5.31E-03	2.25E-02

Stainless Steel Followed by Lead

65 keV SS-Pb Dose (Fractional Difference)

Full	1	2	3	4	5	6	7	8	9	10
1	1.43E-02	1.72E-02	1.54E-02	1.17E-02	7.21E-03	2.79E-03	-1.20E-03	-4.36E-03	-6.58E-03	-7.62E-03
2	-3.20E-03	5.97E-03	7.66E-03	6.26E-03	3.54E-03	5.57E-04	-2.18E-03	-4.21E-03	-5.35E-03	-5.36E-03
3	-1.20E-02	-1.12E-04	3.33E-03	3.26E-03	1.64E-03	-3.75E-04	-2.20E-03	-3.35E-03	-3.62E-03	-2.74E-03
4	-1.56E-02	-2.75E-03	1.42E-03	1.97E-03	9.54E-04	-4.40E-04	-1.62E-03	-2.10E-03	-1.65E-03	-7.93E-06
5	-1.57E-02	-3.02E-03	1.14E-03	1.80E-03	1.01E-03	-5.55E-05	-8.25E-04	-7.91E-04	2.54E-04	2.56E-03
6	-1.34E-02	-1.69E-03	1.86E-03	2.21E-03	1.33E-03	3.61E-04	-2.77E-04	1.28E-04	1.70E-03	4.64E-03
7	-9.48E-03	5.76E-04	3.07E-03	2.75E-03	1.57E-03	5.06E-04	1.39E-04	8.28E-04	2.81E-03	5.88E-03
8	-4.73E-03	3.00E-03	3.96E-03	2.68E-03	9.59E-04	-3.21E-04	-6.83E-04	1.98E-04	2.14E-03	6.11E-03
9	2.02E-04	4.98E-03	4.04E-03	1.57E-03	-8.36E-04	-2.45E-03	-2.86E-03	-1.81E-03	8.61E-04	4.91E-03
10	4.28E-03	5.54E-03	2.39E-03	-1.41E-03	-4.59E-03	-6.55E-03	-7.02E-03	-5.82E-03	-2.81E-03	1.73E-03

Low	1	2	3	4	5	6	7	8	9	10
1	5.49E-03	7.48E-03	6.10E-03	3.71E-03	1.11E-03	-1.09E-03	-2.65E-03	-3.22E-03	-2.73E-03	-9.69E-04
2	-8.18E-03	-5.66E-04	1.11E-03	6.41E-04	-5.48E-04	-1.62E-03	-2.18E-03	-1.86E-03	-5.19E-04	2.08E-03
3	-1.01E-02	-1.06E-03	1.25E-03	1.15E-03	2.28E-04	-6.08E-04	-9.36E-04	-3.47E-04	1.30E-03	4.25E-03
4	-6.51E-03	1.78E-03	3.35E-03	2.60E-03	1.14E-03	-1.12E-04	-7.41E-04	-3.71E-04	1.16E-03	4.05E-03
5	-1.94E-03	4.53E-03	4.57E-03	2.58E-03	9.52E-05	-1.98E-03	-3.29E-03	-3.46E-03	-2.38E-03	1.49E-04

High	1	2	3	4	5	6	7	8	9	10
6	-5.97E-04	4.12E-03	3.55E-03	1.68E-03	-2.64E-04	-1.63E-03	-2.35E-03	-1.97E-03	-5.68E-04	1.90E-03
7	-4.30E-03	1.56E-03	1.94E-03	7.29E-04	-6.83E-04	-1.70E-03	-2.02E-03	-1.48E-03	-1.70E-05	2.05E-03
8	-5.38E-03	1.19E-03	2.06E-03	1.18E-03	-4.83E-05	-9.85E-04	-1.34E-03	-9.14E-04	-1.86E-05	2.21E-03
9	-5.10E-03	1.84E-03	2.93E-03	2.11E-03	8.46E-04	-2.47E-04	-8.24E-04	-7.01E-04	2.27E-04	1.63E-03
10	-4.71E-03	2.37E-03	3.46E-03	2.53E-03	1.03E-03	-3.63E-04	-1.32E-03	-1.65E-03	-1.24E-03	-4.02E-04

100 keV SS-Pb Dose (Fractional Difference)

Full	1	2	3	4	5	6	7	8	9	10
1	1.66E-01	1.27E-01	1.13E-01	1.00E-01	8.16E-02	5.57E-02	2.55E-02	-3.57E-03	-2.37E-02	-2.57E-02
2	4.36E-02	2.88E-02	2.95E-02	2.83E-02	1.96E-02	3.41E-03	-1.67E-02	-3.42E-02	-4.07E-02	-2.57E-02
3	-2.54E-02	-2.66E-02	-1.58E-02	-9.02E-03	-9.80E-03	-1.81E-02	-2.96E-02	-3.74E-02	-3.20E-02	-1.21E-03
4	-6.26E-02	-5.50E-02	-3.72E-02	-2.42E-02	-1.92E-02	-2.16E-02	-2.69E-02	-2.72E-02	-1.24E-02	3.13E-02
5	-7.73E-02	-6.40E-02	-4.14E-02	-2.42E-02	-1.55E-02	-1.46E-02	-1.62E-02	-1.22E-02	8.28E-03	6.01E-02
6	-7.53E-02	-5.84E-02	-3.30E-02	-1.38E-02	-3.89E-03	-2.30E-03	-3.54E-03	8.79E-04	2.22E-02	7.56E-02
7	-6.04E-02	-4.20E-02	-1.57E-02	3.12E-03	1.15E-02	1.06E-02	6.17E-03	6.68E-03	2.33E-02	7.07E-02
8	-3.59E-02	-1.79E-02	6.95E-03	2.30E-02	2.70E-02	2.04E-02	9.00E-03	1.31E-03	7.98E-03	4.23E-02
9	-4.73E-03	1.07E-02	3.19E-02	4.25E-02	3.93E-02	2.39E-02	2.22E-03	-1.73E-02	-2.48E-02	-8.87E-03
10	3.02E-02	4.10E-02	5.62E-02	5.89E-02	4.59E-02	1.91E-02	-1.54E-02	-4.93E-02	-7.35E-02	-7.85E-02

Low	1	2	3	4	5	6	7	8	9	10
1	7.68E-02	4.04E-02	3.13E-02	2.80E-02	2.28E-02	1.33E-02	6.00E-04	-1.15E-02	-1.77E-02	-1.12E-02
2	-1.00E-02	-2.46E-02	-1.98E-02	-1.25E-02	-8.52E-03	-9.26E-03	-1.26E-02	-1.41E-02	-7.31E-03	1.55E-02
3	-3.77E-02	-4.12E-02	-2.86E-02	-1.59E-02	-7.68E-03	-4.95E-03	-5.16E-03	-3.23E-03	7.71E-03	3.61E-02
4	-2.80E-02	-2.63E-02	-1.08E-02	2.59E-03	9.53E-03	9.15E-03	4.42E-03	6.18E-04	4.65E-03	2.46E-02
5	7.72E-03	9.61E-03	2.34E-02	3.22E-02	3.17E-02	2.13E-02	4.02E-03	-1.45E-02	-2.78E-02	-2.90E-02

High	1	2	3	4	5	6	7	8	9	10
6	-4.34E-02	-7.98E-02	-9.34E-02	-1.02E-01	-1.10E-01	-1.18E-01	-1.24E-01	-1.27E-01	-1.23E-01	-1.12E-01
7	-6.56E-02	-9.59E-02	-1.05E-01	-1.10E-01	-1.14E-01	-1.19E-01	-1.24E-01	-1.25E-01	-1.20E-01	-1.08E-01
8	-7.73E-02	-1.03E-01	-1.08E-01	-1.10E-01	-1.12E-01	-1.16E-01	-1.20E-01	-1.21E-01	-1.18E-01	-1.08E-01
9	-8.05E-02	-1.02E-01	-1.04E-01	-1.04E-01	-1.06E-01	-1.10E-01	-1.16E-01	-1.19E-01	-1.20E-01	-1.15E-01
10	-7.69E-02	-9.58E-02	-9.61E-02	-9.52E-02	-9.73E-02	-1.03E-01	-1.12E-01	-1.20E-01	-1.27E-01	-1.30E-01

500 keV SS-Pb Dose (Fractional Difference)

Full	1	2	3	4	5	6	7	8	9	10
1	6.06E-02	7.60E-02	6.53E-02	4.82E-02	3.10E-02	1.64E-02	5.25E-03	-1.71E-03	-4.10E-03	-1.52E-03
2	-2.42E-02	1.86E-02	2.39E-02	1.76E-02	8.33E-03	-3.18E-04	-6.52E-03	-9.30E-03	-7.95E-03	-1.94E-03
3	-5.51E-02	-6.08E-03	4.22E-03	2.20E-03	-3.39E-03	-8.75E-03	-1.20E-02	-1.19E-02	-7.96E-03	6.41E-04
4	-5.51E-02	-1.01E-02	-1.03E-03	-2.76E-03	-7.29E-03	-1.12E-02	-1.28E-02	-1.12E-02	-5.43E-03	5.05E-03
5	-3.85E-02	-2.21E-03	2.47E-03	-1.18E-03	-6.23E-03	-9.97E-03	-1.10E-02	-8.35E-03	-1.65E-03	1.01E-02
6	-1.64E-02	1.04E-02	9.69E-03	3.28E-03	-3.13E-03	-7.35E-03	-8.30E-03	-5.31E-03	2.18E-03	1.47E-02
7	2.24E-03	2.16E-02	1.65E-02	7.50E-03	-2.78E-04	-5.14E-03	-6.45E-03	-3.34E-03	4.49E-03	1.75E-02
8	1.03E-02	2.66E-02	1.90E-02	8.58E-03	-2.67E-05	-5.29E-03	-6.55E-03	-3.56E-03	4.44E-03	1.78E-02
9	3.48E-03	2.21E-02	1.50E-02	4.66E-03	-3.87E-03	-9.20E-03	-1.01E-02	-6.99E-03	1.16E-03	1.46E-02
10	-1.93E-02	6.64E-03	3.00E-03	-5.44E-03	-1.28E-02	-1.72E-02	-1.80E-02	-1.43E-02	-5.93E-03	7.63E-03

Low	1	2	3	4	5	6	7	8	9	10
1	-6.97E-03	2.68E-02	2.68E-02	1.73E-02	6.17E-03	-3.17E-03	-9.20E-03	-1.10E-02	-8.02E-03	4.94E-04
2	-3.70E-02	6.08E-03	1.21E-02	7.14E-03	-1.82E-04	-6.32E-03	-9.47E-03	-8.61E-03	-2.93E-03	8.25E-03
3	-2.58E-02	9.99E-03	1.29E-02	7.00E-03	-2.29E-04	-5.69E-03	-7.83E-03	-5.75E-03	1.27E-03	1.40E-02
4	-8.69E-03	1.82E-02	1.62E-02	7.92E-03	-4.05E-04	-6.22E-03	-8.29E-03	-5.94E-03	1.57E-03	1.49E-02
5	-8.46E-03	1.63E-02	1.25E-02	3.03E-03	-5.82E-03	-1.19E-02	-1.40E-02	-1.17E-02	-4.32E-03	8.91E-03

High	1	2	3	4	5	6	7	8	9	10
6	-2.12E-02	5.44E-03	8.82E-03	6.30E-03	2.79E-03	4.06E-04	3.01E-04	3.23E-03	9.79E-03	2.05E-02
7	-1.10E-02	8.48E-03	7.15E-03	1.85E-03	-3.24E-03	-6.47E-03	-7.16E-03	-4.39E-03	2.14E-03	1.29E-02
8	-3.75E-03	1.30E-02	8.60E-03	1.13E-03	-5.40E-03	-9.59E-03	-1.07E-02	-8.54E-03	-2.29E-03	8.28E-03
9	-2.07E-03	1.62E-02	1.09E-02	2.20E-03	-5.36E-03	-1.05E-02	-1.21E-02	-1.04E-02	-4.50E-03	5.71E-03
10	-7.03E-03	1.64E-02	1.22E-02	3.46E-03	-4.49E-03	-9.93E-03	-1.23E-02	-1.08E-02	-5.34E-03	4.48E-03

1 MeV SS-Pb Dose (Fractional Difference)

Full	1	2	3	4	5	6	7	8	9	10
1	8.66E-02	8.83E-02	7.17E-02	5.14E-02	3.23E-02	1.65E-02	5.01E-03	-1.82E-03	-3.41E-03	5.74E-04
2	-1.67E-02	1.94E-02	2.26E-02	1.53E-02	5.33E-03	-3.46E-03	-9.38E-03	-1.14E-02	-8.80E-03	-9.20E-04
3	-5.60E-02	-9.60E-03	6.38E-04	-1.42E-03	-7.02E-03	-1.22E-02	-1.50E-02	-1.42E-02	-8.80E-03	1.82E-03
4	-6.04E-02	-1.43E-02	-3.77E-03	-5.08E-03	-9.55E-03	-1.34E-02	-1.48E-02	-1.24E-02	-5.41E-03	7.02E-03
5	-4.67E-02	-5.39E-03	1.89E-03	-1.04E-03	-6.27E-03	-1.03E-02	-1.14E-02	-8.46E-03	-6.26E-04	1.28E-02
6	-2.66E-02	8.77E-03	1.17E-02	6.07E-03	-7.97E-04	-5.74E-03	-7.29E-03	-4.38E-03	3.66E-03	1.75E-02
7	-9.19E-03	2.15E-02	2.06E-02	1.23E-02	3.69E-03	-2.39E-03	-4.58E-03	-2.16E-03	5.68E-03	1.95E-02
8	-7.29E-04	2.78E-02	2.47E-02	1.46E-02	4.74E-03	-2.27E-03	-5.14E-03	-3.23E-03	4.18E-03	1.77E-02
9	-4.68E-03	2.49E-02	2.16E-02	1.11E-02	7.43E-04	-6.72E-03	-1.01E-02	-8.60E-03	-1.67E-03	1.12E-02
10	-2.19E-02	1.15E-02	1.02E-02	6.57E-04	-9.25E-03	-1.66E-02	-2.00E-02	-1.88E-02	-1.24E-02	-1.63E-04

Low	1	2	3	4	5	6	7	8	9	10
1	2.34E-02	2.95E-02	2.25E-02	1.24E-02	2.75E-03	-4.68E-03	-8.81E-03	-9.08E-03	-4.75E-03	4.69E-03
2	-3.27E-02	-2.35E-03	2.77E-03	-2.13E-04	-5.15E-03	-9.03E-03	-1.04E-02	-8.16E-03	-1.65E-03	9.89E-03
3	-3.32E-02	2.06E-03	8.08E-03	4.98E-03	-2.59E-04	-4.54E-03	-6.29E-03	-4.36E-03	1.97E-03	1.34E-02
4	-2.23E-02	1.40E-02	1.83E-02	1.30E-02	5.57E-03	-6.93E-04	-4.19E-03	-4.02E-03	6.68E-04	1.04E-02
5	-2.24E-02	1.65E-02	2.04E-02	1.36E-02	4.39E-03	-3.84E-03	-9.44E-03	-1.13E-02	-8.87E-03	-1.56E-03

High	1	2	3	4	5	6	7	8	9	10
6	-2.55E-02	1.46E-02	1.95E-02	1.39E-02	5.81E-03	-1.41E-03	-6.14E-03	-7.30E-03	-4.31E-03	3.38E-03
7	-2.64E-02	1.12E-02	1.51E-02	9.69E-03	2.40E-03	-3.63E-03	-6.85E-03	-6.48E-03	-1.72E-03	7.90E-03
8	-2.00E-02	1.24E-02	1.37E-02	7.27E-03	-3.21E-05	-5.47E-03	-7.75E-03	-6.16E-03	9.20E-06	1.12E-02
9	-1.05E-02	1.51E-02	1.28E-02	4.80E-03	-2.97E-03	-8.20E-03	-9.92E-03	-7.33E-03	-2.35E-06	1.26E-02
10	-2.03E-03	1.63E-02	1.02E-02	4.37E-04	-7.94E-03	-1.31E-02	-1.43E-02	-1.10E-02	-2.73E-03	1.10E-02

2 MeV SS-Pb Dose (Fractional Difference)

Full	1	2	3	4	5	6	7	8	9	10
1	1.44E-01	1.12E-01	8.42E-02	6.14E-02	4.24E-02	2.71E-02	1.54E-02	7.23E-03	2.65E-03	1.70E-03
2	1.42E-02	2.09E-02	1.69E-02	9.87E-03	2.58E-03	-3.65E-03	-8.03E-03	-1.00E-02	-9.22E-03	-5.29E-03
3	-4.02E-02	-1.83E-02	-1.25E-02	-1.24E-02	-1.42E-02	-1.59E-02	-1.63E-02	-1.49E-02	-1.08E-02	-3.80E-03
4	-5.45E-02	-2.74E-02	-1.86E-02	-1.62E-02	-1.61E-02	-1.61E-02	-1.49E-02	-1.18E-02	-6.14E-03	2.53E-03
5	-4.79E-02	-2.01E-02	-1.16E-02	-9.59E-03	-9.74E-03	-9.76E-03	-8.46E-03	-5.12E-03	9.71E-04	1.02E-02
6	-3.27E-02	-6.05E-03	6.82E-04	9.57E-04	-5.94E-04	-1.71E-03	-1.26E-03	1.47E-03	7.11E-03	1.61E-02
7	-1.72E-02	7.84E-03	1.23E-02	1.05E-02	7.04E-03	4.33E-03	3.43E-03	5.00E-03	9.63E-03	1.77E-02
8	-6.88E-03	1.68E-02	1.93E-02	1.54E-02	1.01E-02	5.71E-03	3.28E-03	3.42E-03	6.71E-03	1.34E-02
9	-4.65E-03	1.83E-02	1.92E-02	1.37E-02	6.85E-03	9.43E-04	-2.97E-03	-4.28E-03	-2.48E-03	2.69E-03
10	-1.16E-02	1.11E-02	1.12E-02	4.67E-03	-3.34E-03	-1.05E-02	-1.57E-02	-1.83E-02	-1.80E-02	-1.45E-02

Low	1	2	3	4	5	6	7	8	9	10
1	5.09E-02	3.53E-02	2.36E-02	1.43E-02	6.93E-03	1.38E-03	-2.48E-03	-4.60E-03	-4.81E-03	-3.09E-03
2	-2.39E-02	-1.14E-02	-7.77E-03	-7.01E-03	-7.05E-03	-7.00E-03	-6.27E-03	-4.47E-03	-1.21E-03	3.68E-03
3	-3.20E-02	-1.24E-02	-5.90E-03	-3.71E-03	-3.05E-03	-2.51E-03	-1.38E-03	7.94E-04	4.44E-03	9.73E-03
4	-1.77E-02	1.89E-03	6.31E-03	5.95E-03	4.14E-03	2.43E-03	1.54E-03	1.89E-03	3.87E-03	7.63E-03
5	-5.07E-03	1.28E-02	1.37E-02	9.71E-03	4.37E-03	-6.36E-04	-4.58E-03	-7.09E-03	-7.83E-03	-6.69E-03

High	1	2	3	4	5	6	7	8	9	10
6	-5.82E-03	1.08E-02	1.01E-02	4.93E-03	-5.25E-04	-4.51E-03	-6.24E-03	-5.26E-03	-1.14E-03	6.36E-03
7	-1.37E-02	6.53E-03	7.73E-03	3.72E-03	-1.10E-03	-4.75E-03	-6.33E-03	-5.34E-03	-1.30E-03	6.03E-03
8	-1.64E-02	6.51E-03	8.92E-03	5.40E-03	6.96E-04	-3.09E-03	-4.96E-03	-4.38E-03	-8.45E-04	5.89E-03
9	-1.74E-02	7.63E-03	1.09E-02	7.57E-03	2.71E-03	-1.44E-03	-3.84E-03	-3.92E-03	-1.15E-03	4.70E-03
10	-1.91E-02	7.73E-03	1.17E-02	8.49E-03	3.40E-03	-1.21E-03	-4.25E-03	-5.11E-03	-3.27E-03	1.52E-03

6 MeV SS-Pb Dose (Fractional Difference)

Full	1	2	3	4	5	6	7	8	9	10
1	1.31E-01	1.31E-01	1.27E-01	1.19E-01	1.08E-01	9.31E-02	7.65E-02	5.83E-02	3.91E-02	1.92E-02
2	1.46E-02	3.03E-02	3.76E-02	3.89E-02	3.57E-02	2.89E-02	1.96E-02	8.47E-03	-4.02E-03	-1.73E-02
3	-4.14E-02	-2.06E-02	-8.69E-03	-2.96E-03	-1.74E-03	-3.88E-03	-8.52E-03	-1.49E-02	-2.24E-02	-3.07E-02
4	-6.22E-02	-4.05E-02	-2.74E-02	-1.99E-02	-1.64E-02	-1.58E-02	-1.73E-02	-2.02E-02	-2.39E-02	-2.80E-02
5	-6.10E-02	-4.07E-02	-2.83E-02	-2.07E-02	-1.63E-02	-1.43E-02	-1.38E-02	-1.41E-02	-1.48E-02	-1.53E-02
6	-4.66E-02	-2.92E-02	-1.88E-02	-1.23E-02	-8.23E-03	-5.76E-03	-4.15E-03	-2.77E-03	-1.12E-03	1.37E-03
7	-2.59E-02	-1.26E-02	-5.24E-03	-8.36E-04	1.93E-03	3.88E-03	5.65E-03	7.86E-03	1.10E-02	1.56E-02
8	-4.81E-03	3.56E-03	6.91E-03	8.23E-03	8.74E-03	9.15E-03	1.00E-02	1.20E-02	1.54E-02	2.10E-02
9	1.16E-02	1.43E-02	1.29E-02	1.03E-02	7.57E-03	5.44E-03	4.34E-03	4.78E-03	7.17E-03	1.21E-02
10	1.94E-02	1.60E-02	9.21E-03	1.96E-03	-4.72E-03	-1.03E-02	-1.45E-02	-1.67E-02	-1.68E-02	-1.42E-02

Low	1	2	3	4	5	6	7	8	9	10
1	3.09E-02	3.22E-02	3.25E-02	3.06E-02	2.67E-02	2.10E-02	1.39E-02	6.01E-03	-2.54E-03	-1.14E-02
2	-2.97E-02	-1.75E-02	-9.81E-03	-5.29E-03	-3.17E-03	-2.83E-03	-3.73E-03	-5.37E-03	-7.41E-03	-9.41E-03
3	-3.36E-02	-2.17E-02	-1.40E-02	-9.04E-03	-5.74E-03	-3.53E-03	-1.93E-03	-4.38E-04	1.29E-03	3.70E-03
4	-1.16E-02	-5.19E-03	-2.05E-03	-3.64E-04	6.49E-04	1.47E-03	2.53E-03	4.24E-03	6.91E-03	1.10E-02
5	1.55E-02	1.36E-02	9.52E-03	5.16E-03	1.18E-03	-2.10E-03	-4.40E-03	-5.38E-03	-4.83E-03	-2.38E-03

High	1	2	3	4	5	6	7	8	9	10
6	-1.83E-04	2.97E-03	4.05E-03	4.66E-03	5.00E-03	4.95E-03	4.26E-03	2.72E-03	-6.14E-05	-4.37E-03
7	-6.95E-03	-4.09E-03	-3.13E-03	-2.29E-03	-1.35E-03	-4.41E-04	1.82E-04	2.80E-04	-5.77E-04	-2.70E-03
8	-5.45E-03	-3.68E-03	-3.59E-03	-3.27E-03	-2.47E-03	-1.34E-03	-1.23E-04	9.00E-04	1.28E-03	6.53E-04
9	6.94E-04	7.53E-04	-6.75E-04	-1.53E-03	-1.55E-03	-8.87E-04	1.81E-04	1.37E-03	2.21E-03	2.31E-03
10	8.60E-03	6.40E-03	2.90E-03	2.51E-04	-1.24E-03	-1.76E-03	-1.59E-03	-1.04E-03	-5.86E-04	-6.43E-04

10 MeV SS-Pb Dose (Fractional Difference)

Full	1	2	3	4	5	6	7	8	9	10
1	8.62E-02	1.02E-01	1.20E-01	1.33E-01	1.40E-01	1.39E-01	1.29E-01	1.11E-01	8.29E-02	4.48E-02
2	-1.64E-02	4.46E-03	2.41E-02	3.93E-02	4.86E-02	5.14E-02	4.70E-02	3.48E-02	1.40E-02	-1.63E-02
3	-6.32E-02	-4.36E-02	-2.53E-02	-1.07E-02	-4.95E-04	4.55E-03	3.78E-03	-3.48E-03	-1.83E-02	-4.17E-02
4	-7.64E-02	-6.06E-02	-4.53E-02	-3.22E-02	-2.23E-02	-1.59E-02	-1.38E-02	-1.68E-02	-2.59E-02	-4.29E-02
5	-6.85E-02	-5.76E-02	-4.62E-02	-3.56E-02	-2.66E-02	-1.95E-02	-1.52E-02	-1.43E-02	-1.82E-02	-2.88E-02
6	-4.73E-02	-4.22E-02	-3.54E-02	-2.80E-02	-2.06E-02	-1.37E-02	-7.90E-03	-3.88E-03	-3.08E-03	-7.57E-03
7	-1.90E-02	-2.04E-02	-1.87E-02	-1.52E-02	-1.05E-02	-4.75E-03	1.42E-03	7.34E-03	1.16E-02	1.22E-02
8	1.15E-02	3.23E-03	-1.07E-03	-2.39E-03	-1.31E-03	1.93E-03	6.82E-03	1.27E-02	1.84E-02	2.17E-02
9	4.05E-02	2.47E-02	1.37E-02	6.62E-03	2.78E-03	1.92E-03	3.53E-03	7.02E-03	1.11E-02	1.37E-02
10	6.47E-02	4.09E-02	2.26E-02	8.79E-03	-1.23E-03	-7.83E-03	-1.16E-02	-1.32E-02	-1.39E-02	-1.59E-02

Low	1	2	3	4	5	6	7	8	9	10
1	1.02E-02	1.49E-02	2.40E-02	3.17E-02	3.60E-02	3.61E-02	3.16E-02	2.22E-02	7.66E-03	-1.25E-02
2	-3.91E-02	-3.07E-02	-2.03E-02	-1.12E-02	-4.34E-03	-2.99E-04	6.83E-04	-1.53E-03	-7.32E-03	-1.72E-02
3	-3.41E-02	-3.01E-02	-2.36E-02	-1.71E-02	-1.13E-02	-6.55E-03	-3.02E-03	-7.01E-04	8.38E-05	-1.18E-03
4	-1.30E-03	-5.80E-03	-6.58E-03	-5.82E-03	-4.29E-03	-2.11E-03	5.96E-04	3.93E-03	7.72E-03	1.16E-02
5	4.13E-02	2.56E-02	1.48E-02	6.96E-03	1.13E-03	-2.83E-03	-5.05E-03	-5.45E-03	-4.14E-03	-1.46E-03

High	1	2	3	4	5	6	7	8	9	10
6	-2.34E-02	-1.48E-02	-6.22E-03	1.15E-03	6.94E-03	1.07E-02	1.20E-02	1.03E-02	4.23E-03	-7.66E-03
7	-1.69E-02	-1.39E-02	-9.76E-03	-5.59E-03	-1.82E-03	1.32E-03	3.33E-03	3.64E-03	1.07E-03	-6.13E-03
8	-3.21E-03	-5.82E-03	-6.42E-03	-5.78E-03	-4.38E-03	-2.37E-03	-2.05E-04	1.58E-03	1.86E-03	-1.17E-03
9	1.47E-02	6.20E-03	6.71E-04	-2.57E-03	-3.97E-03	-3.67E-03	-2.07E-03	3.53E-04	2.55E-03	2.70E-03
10	3.41E-02	1.96E-02	8.92E-03	1.42E-03	-3.32E-03	-5.44E-03	-5.30E-03	-3.34E-03	-5.44E-04	1.31E-03

Lead followed by Stainless Steel

65 keV Pb-SS Dose (Fractional Difference)

Full	1	2	3	4	5	6	7	8	9	10
1	8.26E-03	8.82E-03	9.68E-03	8.97E-03	6.95E-03	4.20E-03	1.26E-03	-1.47E-03	-3.55E-03	-4.85E-03
2	-2.25E-03	1.32E-03	3.90E-03	4.42E-03	3.43E-03	1.61E-03	-4.54E-04	-2.34E-03	-3.58E-03	-4.02E-03
3	-7.34E-03	-2.59E-03	7.55E-04	1.92E-03	1.54E-03	3.23E-04	-1.11E-03	-2.33E-03	-2.88E-03	-2.60E-03
4	-9.04E-03	-4.04E-03	-5.09E-04	8.84E-04	8.00E-04	-3.92E-05	-1.03E-03	-1.76E-03	-1.75E-03	-8.40E-04
5	-8.51E-03	-3.83E-03	-5.19E-04	7.98E-04	7.76E-04	1.11E-04	-5.89E-04	-9.33E-04	-4.61E-04	9.80E-04
6	-6.47E-03	-2.54E-03	2.43E-04	1.25E-03	1.11E-03	4.77E-04	-5.84E-05	-1.19E-04	7.32E-04	2.64E-03
7	-3.66E-03	-7.92E-04	1.23E-03	1.74E-03	1.33E-03	5.97E-04	1.69E-04	3.07E-04	1.47E-03	3.79E-03
8	-6.45E-04	9.20E-04	2.01E-03	1.90E-03	1.12E-03	2.26E-04	-1.93E-04	9.59E-05	1.53E-03	4.23E-03
9	1.82E-03	1.95E-03	2.00E-03	1.18E-03	-2.67E-05	-1.11E-03	-1.56E-03	-1.22E-03	5.33E-04	3.60E-03
10	3.09E-03	1.71E-03	6.71E-04	-8.67E-04	-2.51E-03	-3.79E-03	-4.34E-03	-3.81E-03	-1.88E-03	1.55E-03

Low	1	2	3	4	5	6	7	8	9	10
1	4.30E-03	2.45E-03	2.95E-03	2.96E-03	2.21E-03	9.80E-04	-3.86E-04	-1.58E-03	-2.24E-03	-2.26E-03
2	-3.51E-03	-2.63E-03	-5.97E-04	5.17E-04	6.89E-04	2.77E-04	-2.95E-04	-7.29E-04	-6.23E-04	1.35E-04
3	-4.32E-03	-3.18E-03	-1.05E-03	1.99E-04	5.64E-04	4.23E-04	1.78E-04	1.31E-04	6.76E-04	1.93E-03
4	-1.31E-03	-1.35E-03	-4.73E-05	6.32E-04	6.56E-04	3.45E-04	6.11E-05	8.64E-05	7.96E-04	2.29E-03
5	3.23E-03	1.10E-03	9.08E-04	5.24E-04	-1.94E-04	-1.01E-03	-1.60E-03	-1.75E-03	-1.09E-03	4.36E-04

High	1	2	3	4	5	6	7	8	9	10
6	5.09E-04	-4.98E-04	5.80E-04	1.34E-03	1.43E-03	1.00E-03	3.12E-04	-4.45E-04	-9.54E-04	-1.16E-03
7	-6.74E-04	-1.67E-03	-5.03E-04	4.01E-04	6.99E-04	5.03E-04	1.44E-04	-2.85E-04	-4.29E-04	-2.34E-04
8	-3.60E-04	-1.67E-03	-6.87E-04	1.49E-04	4.66E-04	3.70E-04	1.72E-04	-3.95E-05	8.04E-05	5.81E-04
9	8.20E-04	-1.07E-03	-4.83E-04	9.68E-05	2.91E-04	1.69E-04	1.73E-05	-1.44E-04	2.22E-04	9.59E-04
10	2.41E-03	-2.88E-04	-2.80E-04	-9.74E-05	-1.54E-04	-4.01E-04	-6.66E-04	-7.26E-04	-3.21E-04	5.87E-04

100 keV Pb-SS Dose (Log Fit Fractional Difference)

Full	1	2	3	4	5	6	7	8	9	10
1	-4.01E-02	2.03E-01	1.50E-01	8.43E-02	2.97E-02	-1.16E-02	-3.97E-02	-5.46E-02	-5.56E-02	-4.06E-02
2	-6.69E-02	1.20E-01	9.02E-02	3.75E-02	-1.05E-02	-4.84E-02	-7.49E-02	-8.97E-02	-9.18E-02	-7.93E-02
3	-4.87E-02	9.13E-02	7.12E-02	2.33E-02	-2.32E-02	-6.08E-02	-8.78E-02	-1.04E-01	-1.07E-01	-9.68E-02
4	-2.55E-02	8.51E-02	7.51E-02	3.11E-02	-1.50E-02	-5.37E-02	-8.23E-02	-9.97E-02	-1.05E-01	-9.65E-02
5	-1.07E-02	7.83E-02	8.67E-02	5.21E-02	8.50E-03	-3.07E-02	-6.07E-02	-7.98E-02	-8.67E-02	-7.97E-02
6	-7.84E-03	5.27E-02	8.89E-02	7.47E-02	4.05E-02	4.43E-03	-2.54E-02	-4.52E-02	-5.31E-02	-4.69E-02
7	-1.11E-02	-2.45E-03	6.33E-02	8.28E-02	7.01E-02	4.52E-02	2.03E-02	2.37E-03	-4.80E-03	1.99E-03
8	-5.90E-03	-8.55E-02	-3.58E-03	5.70E-02	8.07E-02	8.01E-02	6.95E-02	5.95E-02	5.70E-02	6.71E-02
9	3.06E-02	-1.82E-01	-1.10E-01	-1.70E-02	5.19E-02	9.12E-02	1.10E-01	1.19E-01	1.28E-01	1.47E-01
10	1.35E-01	-2.74E-01	-2.38E-01	-1.36E-01	-3.02E-02	5.71E-02	1.20E-01	1.64E-01	2.00E-01	2.38E-01

Low	1	2	3	4	5	6	7	8	9	10
1	-2.55E-02	8.98E-02	5.74E-02	1.31E-02	-2.28E-02	-4.59E-02	-5.43E-02	-4.54E-02	-1.49E-02	4.51E-02
2	-4.06E-02	7.77E-02	5.19E-02	9.71E-03	-2.58E-02	-4.90E-02	-5.75E-02	-4.90E-02	-1.90E-02	4.03E-02
3	-3.29E-02	7.70E-02	5.77E-02	1.70E-02	-1.89E-02	-4.30E-02	-5.25E-02	-4.47E-02	-1.55E-02	4.30E-02
4	-3.37E-02	7.10E-02	6.53E-02	2.98E-02	-5.21E-03	-2.99E-02	-4.03E-02	-3.36E-02	-5.33E-03	5.22E-02
5	-7.04E-02	3.97E-02	6.11E-02	3.97E-02	1.03E-02	-1.27E-02	-2.32E-02	-1.70E-02	1.05E-02	6.72E-02

High	1	2	3	4	5	6	7	8	9	10
6	-7.88E-02	-8.55E-02	6.01E-03	2.37E-02	2.63E-03	-3.27E-02	-7.06E-02	-1.06E-01	-1.36E-01	-1.61E-01
7	-6.50E-02	-1.05E-01	-1.19E-02	2.75E-02	2.25E-02	-5.10E-03	-4.09E-02	-7.71E-02	-1.10E-01	-1.38E-01
8	-9.84E-02	-1.61E-01	-6.13E-02	1.08E-02	3.71E-02	3.00E-02	4.58E-03	-2.79E-02	-6.09E-02	-9.08E-02
9	-9.92E-02	-2.28E-01	-1.40E-01	-4.17E-02	2.49E-02	5.35E-02	5.26E-02	3.38E-02	6.94E-03	-2.15E-02
10	-1.96E-02	-2.79E-01	-2.30E-01	-1.27E-01	-2.76E-02	4.53E-02	8.46E-02	9.52E-02	8.65E-02	6.75E-02

500 keV Pb-SS Dose (Fractional Difference)

Full	1	2	3	4	5	6	7	8	9	10
1	4.26E-02	6.45E-02	7.17E-02	6.86E-02	5.95E-02	4.72E-02	3.31E-02	1.81E-02	2.97E-03	-1.22E-02
2	-2.76E-02	5.97E-03	2.25E-02	2.75E-02	2.57E-02	1.99E-02	1.17E-02	2.22E-03	-8.01E-03	-1.86E-02
3	-5.88E-02	-2.38E-02	-4.26E-03	4.62E-03	6.92E-03	5.20E-03	1.12E-03	-4.50E-03	-1.10E-02	-1.79E-02
4	-6.73E-02	-3.61E-02	-1.68E-02	-6.61E-03	-2.15E-03	-1.25E-03	-2.53E-03	-5.21E-03	-8.68E-03	-1.26E-02
5	-6.06E-02	-3.67E-02	-2.00E-02	-1.02E-02	-4.98E-03	-2.63E-03	-2.00E-03	-2.49E-03	-3.61E-03	-5.09E-03
6	-4.36E-02	-2.93E-02	-1.71E-02	-9.12E-03	-4.18E-03	-1.27E-03	4.97E-04	1.53E-03	2.15E-03	2.74E-03
7	-1.96E-02	-1.71E-02	-1.07E-02	-5.63E-03	-2.00E-03	6.46E-04	2.79E-03	4.77E-03	6.72E-03	8.71E-03
8	8.20E-03	-2.50E-03	-3.16E-03	-2.05E-03	-5.44E-04	1.09E-03	2.97E-03	5.18E-03	7.81E-03	1.09E-02
9	3.72E-02	1.21E-02	3.45E-03	-2.14E-04	-1.68E-03	-1.71E-03	-7.60E-04	1.11E-03	3.82E-03	7.27E-03
10	6.49E-02	2.46E-02	7.34E-03	-1.80E-03	-6.82E-03	-9.23E-03	-9.83E-03	-8.94E-03	-6.79E-03	-3.56E-03

Low	1	2	3	4	5	6	7	8	9	10
1	1.31E-03	1.45E-02	2.19E-02	2.32E-02	2.07E-02	1.60E-02	1.01E-02	3.37E-03	-3.70E-03	-1.10E-02
2	-3.76E-02	-2.00E-02	-7.59E-03	-1.02E-03	1.79E-03	2.28E-03	1.45E-03	-2.79E-04	-2.56E-03	-5.24E-03
3	-3.12E-02	-2.26E-02	-1.37E-02	-7.75E-03	-3.99E-03	-1.64E-03	-6.88E-05	9.35E-04	1.62E-03	2.08E-03
4	1.44E-03	-7.08E-03	-6.84E-03	-5.35E-03	-3.75E-03	-2.10E-03	-3.22E-04	1.56E-03	3.58E-03	5.69E-03
5	4.87E-02	1.79E-02	5.85E-03	-5.59E-05	-3.01E-03	-4.21E-03	-4.09E-03	-3.04E-03	-1.27E-03	1.02E-03

High	1	2	3	4	5	6	7	8	9	10
6	-1.77E-02	-6.42E-03	2.55E-03	6.93E-03	8.08E-03	7.07E-03	4.84E-03	1.83E-03	-1.61E-03	-5.09E-03
7	-1.40E-02	-8.76E-03	-2.31E-03	1.42E-03	2.89E-03	2.83E-03	1.90E-03	5.38E-04	-1.06E-03	-2.74E-03
8	-4.31E-03	-6.46E-03	-3.41E-03	-1.11E-03	1.12E-04	4.94E-04	4.49E-04	2.52E-04	1.07E-04	1.14E-04
9	9.54E-03	-1.06E-03	-2.18E-03	-1.93E-03	-1.59E-03	-1.20E-03	-7.63E-04	-9.54E-05	8.88E-04	2.23E-03
10	2.60E-02	6.03E-03	7.38E-05	-2.30E-03	-3.27E-03	-3.37E-03	-2.85E-03	-1.70E-03	7.74E-05	2.45E-03

1 MeV Pb-SS Dose (Fractional Difference)

Full	1	2	3	4	5	6	7	8	9	10
1	1.02E-01	1.10E-01	1.04E-01	8.99E-02	7.24E-02	5.36E-02	3.49E-02	1.70E-02	1.98E-04	-1.52E-02
2	-7.20E-03	2.34E-02	3.48E-02	3.50E-02	2.91E-02	2.01E-02	9.63E-03	-1.20E-03	-1.18E-02	-2.18E-02
3	-5.64E-02	-2.01E-02	-1.89E-03	5.18E-03	5.67E-03	2.58E-03	-2.51E-03	-8.46E-03	-1.46E-02	-2.05E-02
4	-7.28E-02	-3.83E-02	-1.85E-02	-8.55E-03	-4.62E-03	-4.19E-03	-5.78E-03	-8.37E-03	-1.12E-02	-1.40E-02
5	-6.88E-02	-4.04E-02	-2.22E-02	-1.19E-02	-6.55E-03	-4.23E-03	-3.67E-03	-3.97E-03	-4.47E-03	-4.86E-03
6	-5.16E-02	-3.22E-02	-1.79E-02	-9.05E-03	-3.86E-03	-8.89E-04	8.06E-04	1.95E-03	3.08E-03	4.48E-03
7	-2.66E-02	-1.84E-02	-9.76E-03	-3.73E-03	1.26E-04	2.78E-03	4.80E-03	6.65E-03	8.73E-03	1.14E-02
8	1.75E-03	-2.89E-03	-1.20E-03	8.33E-04	2.50E-03	4.00E-03	5.54E-03	7.45E-03	1.00E-02	1.33E-02
9	2.93E-02	1.08E-02	4.61E-03	1.87E-03	5.64E-04	2.51E-04	7.55E-04	2.15E-03	4.58E-03	8.05E-03
10	5.25E-02	1.96E-02	5.02E-03	-3.04E-03	-7.83E-03	-1.05E-02	-1.15E-02	-1.11E-02	-9.25E-03	-6.09E-03

Low	1	2	3	4	5	6	7	8	9	10
1	1.46E+00	2.26E-01	3.36E-01	1.99E-01	9.94E-02	3.54E-02	1.65E-03	-4.29E-03	1.94E-02	7.98E-02
2	8.51E-01	-3.70E-04	2.40E-01	1.01E-01	1.32E-02	-3.92E-02	-6.31E-02	-6.03E-02	-2.82E-02	4.17E-02
3	5.76E-01	1.75E-01	1.75E-01	2.55E-02	-5.28E-02	-9.51E-02	-1.10E-01	-9.76E-02	-5.53E-02	2.84E-02
4	4.27E-01	1.30E-01	2.35E-01	-2.88E-02	-9.97E-02	-1.32E-01	-1.37E-01	-1.14E-01	-5.79E-02	4.73E-02
5	3.30E-01	7.99E-02	-1.37E-01	-3.44E-02	-1.19E-01	-1.44E-01	-1.38E-01	-1.01E-01	-2.31E-02	1.20E-01

High	1	2	3	4	5	6	7	8	9	10
6	-9.86E-03	-1.89E-03	4.73E-03	7.64E-03	7.79E-03	6.23E-03	3.65E-03	6.29E-04	-2.41E-03	-5.27E-03
7	-1.11E-02	-7.02E-03	-1.61E-03	1.51E-03	2.51E-03	2.25E-03	1.23E-03	-1.37E-04	-1.50E-03	-2.57E-03
8	-5.00E-03	-6.31E-03	-3.22E-03	-9.19E-04	2.20E-04	5.81E-04	4.59E-04	2.34E-04	1.97E-04	4.74E-04
9	5.73E-03	-2.16E-03	-2.30E-03	-1.52E-03	-9.33E-04	-5.16E-04	-1.78E-04	3.13E-04	1.19E-03	2.53E-03
10	1.87E-02	3.33E-03	-7.78E-04	-2.15E-03	-2.65E-03	-2.64E-03	-2.27E-03	-1.42E-03	3.90E-05	2.11E-03

2 MeV Pb-SS Dose (Fractional Difference)

Full	1	2	3	4	5	6	7	8	9	10
1	1.26E-01	1.14E-01	9.86E-02	7.99E-02	6.04E-02	4.12E-02	2.30E-02	6.20E-03	-9.00E-03	-2.26E-02
2	8.82E-03	2.68E-02	3.26E-02	3.05E-02	2.39E-02	1.50E-02	5.17E-03	-4.73E-03	-1.42E-02	-2.28E-02
3	-4.52E-02	-1.83E-02	-3.21E-03	3.15E-03	4.01E-03	1.55E-03	-2.70E-03	-7.78E-03	-1.30E-02	-1.80E-02
4	-6.37E-02	-3.73E-02	-1.94E-02	-9.28E-03	-4.46E-03	-3.07E-03	-3.75E-03	-5.56E-03	-7.79E-03	-1.00E-02
5	-6.02E-02	-3.93E-02	-2.27E-02	-1.19E-02	-5.51E-03	-2.19E-03	-8.13E-04	-5.44E-04	-7.23E-04	-9.62E-04
6	-4.30E-02	-3.08E-02	-1.82E-02	-8.82E-03	-2.61E-03	1.24E-03	3.54E-03	4.95E-03	6.04E-03	7.12E-03
7	-1.85E-02	-1.72E-02	-1.01E-02	-3.71E-03	1.07E-03	4.40E-03	6.75E-03	8.57E-03	1.03E-02	1.21E-02
8	7.78E-03	-2.76E-03	-2.35E-03	1.16E-04	2.62E-03	4.69E-03	6.44E-03	8.10E-03	9.96E-03	1.22E-02
9	3.14E-02	8.76E-03	2.03E-03	7.65E-05	-2.10E-04	1.29E-04	8.52E-04	1.96E-03	3.59E-03	5.78E-03
10	4.86E-02	1.43E-02	5.35E-04	-5.96E-03	-9.22E-03	-1.08E-02	-1.14E-02	-1.11E-02	-9.98E-03	-8.04E-03

Low	1	2	3	4	5	6	7	8	9	10
1	3.13E-02	3.19E-02	3.00E-02	2.52E-02	1.89E-02	1.20E-02	5.06E-03	-1.58E-03	-7.68E-03	-1.32E-02
2	-3.38E-02	-1.84E-02	-7.87E-03	-2.17E-03	3.26E-04	8.21E-04	1.98E-04	-9.82E-04	-2.33E-03	-3.67E-03
3	-3.35E-02	-2.46E-02	-1.51E-02	-8.19E-03	-3.53E-03	-5.19E-04	1.44E-03	2.77E-03	3.81E-03	4.75E-03
4	-2.36E-03	-9.17E-03	-7.53E-03	-4.66E-03	-2.00E-03	1.97E-04	2.01E-03	3.61E-03	5.18E-03	6.80E-03
5	3.87E-02	1.27E-02	3.15E-03	-8.96E-04	-2.68E-03	-3.45E-03	-3.61E-03	-3.33E-03	-2.63E-03	-1.56E-03

High	1	2	3	4	5	6	7	8	9	10
6	-5.21E-03	-1.66E-05	5.57E-03	7.99E-03	7.72E-03	5.63E-03	2.59E-03	-7.14E-04	-3.77E-03	-6.26E-03
7	-8.66E-03	-6.34E-03	-1.20E-03	1.96E-03	3.00E-03	2.51E-03	1.18E-03	-3.90E-04	-1.71E-03	-2.49E-03
8	-4.23E-03	-6.57E-03	-3.29E-03	-5.76E-04	8.04E-04	1.10E-03	8.16E-04	4.38E-04	3.91E-04	9.25E-04
9	4.98E-03	-3.26E-03	-2.89E-03	-1.49E-03	-5.05E-04	-4.22E-05	2.03E-04	5.78E-04	1.42E-03	2.94E-03
10	1.60E-02	1.06E-03	-2.18E-03	-2.72E-03	-2.65E-03	-2.46E-03	-2.09E-03	-1.33E-03	1.01E-04	2.34E-03

6 MeV Pb-SS Dose (Fractional Difference)

Full	1	2	3	4	5	6	7	8	9	10
1	7.63E-02	6.31E-02	5.19E-02	4.08E-02	3.02E-02	2.07E-02	1.27E-02	6.59E-03	2.50E-03	6.27E-04
2	-1.04E-03	6.72E-03	9.10E-03	7.60E-03	4.19E-03	3.58E-04	-3.03E-03	-5.29E-03	-6.02E-03	-4.91E-03
3	-3.24E-02	-1.84E-02	-1.06E-02	-7.81E-03	-7.65E-03	-8.51E-03	-9.36E-03	-9.40E-03	-8.13E-03	-5.20E-03
4	-3.71E-02	-2.36E-02	-1.50E-02	-1.10E-02	-9.61E-03	-9.34E-03	-9.12E-03	-8.17E-03	-5.96E-03	-2.12E-03
5	-2.79E-02	-1.78E-02	-1.05E-02	-6.90E-03	-5.69E-03	-5.41E-03	-5.11E-03	-4.00E-03	-1.61E-03	2.44E-03
6	-1.36E-02	-7.62E-03	-2.32E-03	4.83E-05	4.72E-04	1.76E-04	3.50E-05	7.74E-04	2.87E-03	6.66E-03
7	-3.85E-04	1.76E-03	5.09E-03	6.24E-03	5.78E-03	4.75E-03	3.98E-03	4.13E-03	5.67E-03	8.93E-03
8	7.47E-03	6.70E-03	8.64E-03	8.94E-03	7.83E-03	6.22E-03	4.88E-03	4.44E-03	5.37E-03	7.99E-03
9	7.41E-03	4.85E-03	6.14E-03	6.16E-03	4.84E-03	2.98E-03	1.29E-03	4.31E-04	8.38E-04	2.84E-03
10	-1.62E-03	-4.90E-03	-3.48E-03	-3.11E-03	-4.13E-03	-5.83E-03	-7.53E-03	-8.57E-03	-8.50E-03	-6.98E-03

Low	1	2	3	4	5	6	7	8	9	10
1	3.48E-02	2.21E-02	1.55E-02	1.06E-02	6.40E-03	2.89E-03	4.14E-05	-2.07E-03	-3.42E-03	-4.02E-03
2	-1.43E-02	-1.02E-02	-6.53E-03	-4.46E-03	-3.44E-03	-2.85E-03	-2.34E-03	-1.60E-03	-4.57E-04	1.18E-03
3	-2.02E-02	-1.38E-02	-8.26E-03	-4.83E-03	-2.78E-03	-1.38E-03	-1.92E-04	1.16E-03	2.85E-03	5.00E-03
4	-7.36E-03	-4.43E-03	-1.07E-03	6.67E-04	1.28E-03	1.41E-03	1.49E-03	1.86E-03	2.67E-03	4.03E-03
5	8.15E-03	5.92E-03	5.75E-03	4.61E-03	2.70E-03	5.75E-04	-1.40E-03	-2.93E-03	-3.86E-03	-4.13E-03

High	1	2	3	4	5	6	7	8	9	10
6	-1.48E-03	-1.18E-03	7.76E-04	1.23E-03	5.73E-04	-3.73E-04	-1.03E-03	-8.84E-04	3.55E-04	2.89E-03
7	-2.59E-04	-1.24E-03	4.42E-04	8.27E-04	7.14E-05	-1.06E-03	-1.98E-03	-2.19E-03	-1.37E-03	7.05E-04
8	1.63E-03	-2.05E-04	1.49E-03	2.01E-03	1.31E-03	9.97E-05	-1.04E-03	-1.57E-03	-1.16E-03	4.14E-04
9	1.37E-03	-6.94E-04	1.47E-03	2.53E-03	2.22E-03	1.20E-03	6.09E-05	-6.30E-04	-5.20E-04	6.44E-04
10	-2.68E-03	-4.30E-03	-1.14E-03	9.18E-04	1.40E-03	9.13E-04	6.87E-05	-5.42E-04	-5.29E-04	3.86E-04

10 MeV Pb-SS Dose (Fractional Difference)

Full	1	2	3	4	5	6	7	8	9	10
1	2.36E-02	5.63E-02	6.21E-02	5.50E-02	4.25E-02	2.90E-02	1.71E-02	8.43E-03	4.12E-03	5.17E-03
2	-4.23E-02	4.60E-03	2.09E-02	2.15E-02	1.49E-02	6.08E-03	-2.04E-03	-7.55E-03	-9.04E-03	-5.40E-03
3	-6.31E-02	-1.67E-02	2.07E-03	5.45E-03	1.43E-03	-5.13E-03	-1.12E-02	-1.49E-02	-1.46E-02	-9.17E-03
4	-5.85E-02	-1.88E-02	-1.90E-03	1.44E-03	-2.03E-03	-7.82E-03	-1.30E-02	-1.57E-02	-1.43E-02	-7.78E-03
5	-4.12E-02	-1.07E-02	2.64E-03	4.52E-03	5.99E-04	-5.17E-03	-1.01E-02	-1.23E-02	-1.04E-02	-3.03E-03
6	-2.07E-02	7.68E-04	1.01E-02	1.03E-02	5.65E-03	-2.96E-04	-5.12E-03	-7.06E-03	-4.67E-03	3.28E-03
7	-3.49E-03	9.90E-03	1.59E-02	1.47E-02	9.73E-03	3.83E-03	-7.33E-04	-2.27E-03	6.22E-04	9.20E-03
8	5.82E-03	1.28E-02	1.65E-02	1.48E-02	1.01E-02	4.77E-03	8.96E-04	6.62E-05	3.69E-03	1.30E-02
9	4.38E-03	6.83E-03	9.42E-03	8.22E-03	4.55E-03	4.46E-04	-2.21E-03	-1.90E-03	2.78E-03	1.31E-02
10	-9.10E-03	-9.47E-03	-6.82E-03	-6.66E-03	-8.51E-03	-1.07E-02	-1.16E-02	-9.66E-03	-3.57E-03	8.01E-03

Low	1	2	3	4	5	6	7	8	9	10
1	3.61E-02	2.46E-02	1.60E-02	8.67E-03	2.68E-03	-1.72E-03	-4.19E-03	-4.40E-03	-1.97E-03	3.47E-03
2	-1.45E-02	-5.81E-03	-3.19E-03	-3.79E-03	-5.52E-03	-7.01E-03	-7.36E-03	-5.93E-03	-2.13E-03	4.52E-03
3	-2.26E-02	-7.53E-03	-1.04E-03	2.41E-04	-8.15E-04	-2.34E-03	-3.11E-03	-2.30E-03	7.53E-04	6.58E-03
4	-1.70E-02	-3.51E-04	7.19E-03	8.48E-03	6.57E-03	3.63E-03	1.17E-03	5.57E-05	1.06E-03	4.72E-03
5	-1.59E-02	1.28E-03	9.54E-03	1.07E-02	7.92E-03	3.49E-03	-9.41E-04	-4.33E-03	-5.86E-03	-4.97E-03

High	1	2	3	4	5	6	7	8	9	10
6	-2.46E-02	-1.91E-03	8.82E-03	1.03E-02	6.72E-03	1.61E-03	-2.61E-03	-4.18E-03	-1.66E-03	6.18E-03
7	-1.26E-02	2.18E-03	9.31E-03	9.06E-03	4.64E-03	-9.98E-04	-5.62E-03	-7.57E-03	-5.45E-03	1.92E-03
8	-4.43E-03	4.67E-03	9.72E-03	8.87E-03	4.44E-03	-1.04E-03	-5.49E-03	-7.33E-03	-5.18E-03	2.14E-03
9	-2.15E-03	3.24E-03	7.56E-03	7.20E-03	3.67E-03	-8.56E-04	-4.46E-03	-5.58E-03	-2.86E-03	4.91E-03
10	-6.43E-03	-3.27E-03	1.40E-03	2.45E-03	6.64E-04	-2.15E-03	-4.21E-03	-3.98E-03	-1.08E-04	8.66E-03

Aluminum Followed by Stainless Steel

65 keV Al-SS Dose (Fractional Difference)

Full	1	2	3	4	5	6	7	8	9	10
1	1.10E-01	1.01E-01	7.76E-02	5.49E-02	3.62E-02	2.22E-02	1.30E-02	8.66E-03	9.40E-03	1.52E-02
2	1.12E-02	3.32E-02	2.72E-02	1.53E-02	3.93E-03	-4.52E-03	-9.22E-03	-9.60E-03	-5.22E-03	4.17E-03
3	-3.71E-02	-1.03E-03	1.53E-03	-4.84E-03	-1.22E-02	-1.76E-02	-1.96E-02	-1.75E-02	-1.06E-02	1.40E-03
4	-5.45E-02	-1.25E-02	-6.42E-03	-1.06E-02	-1.64E-02	-2.04E-02	-2.12E-02	-1.77E-02	-9.22E-03	4.69E-03
5	-5.25E-02	-8.97E-03	-2.49E-03	-6.64E-03	-1.25E-02	-1.65E-02	-1.70E-02	-1.30E-02	-3.68E-03	1.15E-02
6	-3.96E-02	2.94E-03	7.93E-03	2.38E-03	-4.67E-03	-9.59E-03	-1.01E-02	-6.50E-03	2.75E-03	1.91E-02
7	-2.34E-02	1.71E-02	1.94E-02	1.21E-02	3.09E-03	-2.64E-03	-4.78E-03	-1.66E-03	8.13E-03	2.40E-02
8	-1.02E-02	2.75E-02	2.71E-02	1.77E-02	6.93E-03	-1.79E-04	-3.37E-03	-1.02E-03	8.30E-03	2.40E-02
9	-6.61E-03	2.88E-02	2.64E-02	1.54E-02	3.22E-03	-5.04E-03	-9.21E-03	-7.67E-03	9.90E-04	1.62E-02
10	-1.73E-02	1.69E-02	1.39E-02	2.16E-03	-1.06E-02	-1.95E-02	-2.44E-02	-2.36E-02	-1.57E-02	-1.26E-03

Low	1	2	3	4	5	6	7	8	9	10
1	1.29E-02	2.59E-02	2.03E-02	1.10E-02	2.20E-03	-4.57E-03	-8.71E-03	-9.74E-03	-7.30E-03	-1.23E-03
2	-2.93E-02	4.43E-03	8.41E-03	4.24E-03	-1.34E-03	-5.64E-03	-7.57E-03	-6.41E-03	-1.65E-03	6.99E-03
3	-3.42E-02	4.30E-03	9.70E-03	5.90E-03	5.24E-04	-3.42E-03	-4.73E-03	-2.62E-03	3.47E-03	1.38E-02
4	-2.10E-02	1.36E-02	1.54E-02	8.91E-03	1.67E-03	-3.41E-03	-5.24E-03	-3.11E-03	3.49E-03	1.49E-02
5	-6.24E-03	1.99E-02	1.56E-02	5.02E-03	-4.96E-03	-1.18E-02	-1.47E-02	-1.31E-02	-6.54E-03	5.23E-03

High	1	2	3	4	5	6	7	8	9	10
6	-2.69E-02	1.43E-02	1.71E-02	9.31E-03	1.49E-04	-6.62E-03	-8.70E-03	-6.25E-03	2.19E-03	1.81E-02
7	-2.78E-02	1.34E-02	1.54E-02	7.58E-03	-2.21E-03	-8.70E-03	-1.15E-02	-8.88E-03	6.34E-04	1.65E-02
8	-2.28E-02	1.68E-02	1.76E-02	8.61E-03	-2.04E-03	-9.16E-03	-1.24E-02	-9.91E-03	-3.22E-04	1.60E-02
9	-1.67E-02	2.10E-02	2.00E-02	9.75E-03	-1.96E-03	-9.90E-03	-1.37E-02	-1.16E-02	-2.22E-03	1.42E-02
10	-1.28E-02	2.28E-02	2.02E-02	8.63E-03	-4.12E-03	-1.29E-02	-1.74E-02	-1.58E-02	-6.70E-03	9.52E-03

100 keV Al-SS Dose (Fractional Difference)

Full	1	2	3	4	5	6	7	8	9	10
1	1.31E-01	1.25E-01	1.01E-01	7.46E-02	5.11E-02	3.18E-02	1.75E-02	8.59E-03	5.60E-03	9.17E-03
2	3.96E-04	3.68E-02	3.65E-02	2.55E-02	1.25E-02	1.18E-03	-6.82E-03	-1.03E-02	-8.26E-03	1.74E-04
3	-5.74E-02	-4.77E-03	4.84E-03	7.21E-04	-7.05E-03	-1.42E-02	-1.85E-02	-1.85E-02	-1.30E-02	-8.19E-04
4	-7.43E-02	-1.69E-02	-4.73E-03	-6.89E-03	-1.32E-02	-1.86E-02	-2.10E-02	-1.91E-02	-1.11E-02	3.77E-03
5	-6.69E-02	-1.08E-02	-1.00E-04	-3.54E-03	-1.01E-02	-1.59E-02	-1.78E-02	-1.47E-02	-5.54E-03	1.18E-02
6	-4.73E-02	4.77E-03	1.17E-02	5.47E-03	-2.96E-03	-9.73E-03	-1.21E-02	-8.80E-03	1.18E-03	1.99E-02
7	-2.51E-02	2.20E-02	2.45E-02	1.49E-02	4.18E-03	-4.11E-03	-7.31E-03	-4.30E-03	5.92E-03	2.55E-02
8	-8.89E-03	3.39E-02	3.25E-02	2.00E-02	7.21E-03	-2.55E-03	-6.69E-03	-4.48E-03	5.90E-03	2.57E-02
9	-5.81E-03	3.46E-02	3.11E-02	1.69E-02	2.79E-03	-7.95E-03	-1.28E-02	-1.12E-02	-1.18E-03	1.84E-02
10	-2.06E-02	2.03E-02	1.70E-02	2.84E-03	-1.14E-02	-2.24E-02	-2.76E-02	-2.61E-02	-1.69E-02	2.05E-03

Low	1	2	3	4	5	6	7	8	9	10
1	1.17E-02	3.75E-02	3.45E-02	2.31E-02	1.02E-02	-9.65E-04	-8.75E-03	-1.20E-02	-9.93E-03	-1.40E-03
2	-4.64E-02	3.40E-03	1.24E-02	8.15E-03	3.03E-04	-6.81E-03	-1.10E-02	-1.08E-02	-4.99E-03	7.63E-03
3	-4.65E-02	5.15E-03	1.39E-02	9.27E-03	1.54E-03	-5.09E-03	-8.38E-03	-6.77E-03	9.21E-04	1.61E-02
4	-2.64E-02	1.89E-02	2.22E-02	1.40E-02	3.65E-03	-4.32E-03	-8.14E-03	-6.75E-03	1.59E-03	1.78E-02
5	-1.37E-02	2.48E-02	2.28E-02	1.06E-02	-2.17E-03	-1.22E-02	-1.73E-02	-1.65E-02	-8.82E-03	7.47E-03

High	1	2	3	4	5	6	7	8	9	10
6	-3.97E-02	1.67E-02	2.48E-02	1.78E-02	7.68E-03	-1.56E-03	-7.01E-03	-7.43E-03	-1.92E-03	1.13E-02
7	-3.89E-02	1.46E-02	2.09E-02	1.32E-02	3.08E-03	-5.59E-03	-9.98E-03	-8.90E-03	-1.43E-03	1.44E-02
8	-2.96E-02	1.85E-02	2.12E-02	1.16E-02	5.42E-04	-8.26E-03	-1.22E-02	-1.04E-02	-1.08E-03	1.68E-02
9	-1.70E-02	2.41E-02	2.23E-02	9.97E-03	-2.47E-03	-1.18E-02	-1.56E-02	-1.31E-02	-2.67E-03	1.70E-02
10	-6.70E-03	2.69E-02	2.04E-02	5.43E-03	-8.45E-03	-1.84E-02	-2.22E-02	-1.91E-02	-8.04E-03	1.30E-02

500 keV Al-SS Dose (Fractional Difference)

Full	1	2	3	4	5	6	7	8	9	10
1	2.28E-01	1.73E-01	1.34E-01	1.04E-01	7.97E-02	5.97E-02	4.31E-02	2.94E-02	1.82E-02	9.24E-03
2	4.04E-02	3.70E-02	2.88E-02	2.01E-02	1.20E-02	5.09E-03	-4.80E-04	-4.72E-03	-7.58E-03	-9.07E-03
3	-3.50E-02	-2.17E-02	-1.85E-02	-1.82E-02	-1.88E-02	-1.92E-02	-1.90E-02	-1.79E-02	-1.58E-02	-1.25E-02
4	-5.65E-02	-3.81E-02	-3.14E-02	-2.83E-02	-2.61E-02	-2.39E-02	-2.10E-02	-1.73E-02	-1.25E-02	-6.65E-03
5	-5.19E-02	-3.23E-02	-2.56E-02	-2.24E-02	-2.00E-02	-1.73E-02	-1.39E-02	-9.39E-03	-3.72E-03	3.21E-03
6	-3.69E-02	-1.73E-02	-1.16E-02	-9.58E-03	-8.24E-03	-6.46E-03	-3.65E-03	3.11E-04	5.62E-03	1.23E-02
7	-2.08E-02	-1.15E-03	3.14E-03	3.53E-03	3.20E-03	3.39E-03	4.70E-03	7.27E-03	1.13E-02	1.68E-02
8	-9.35E-03	1.06E-02	1.37E-02	1.24E-02	1.01E-02	8.35E-03	7.70E-03	8.31E-03	1.04E-02	1.39E-02
9	-5.52E-03	1.50E-02	1.71E-02	1.41E-02	9.99E-03	6.13E-03	3.28E-03	1.60E-03	1.28E-03	2.38E-03
10	-1.06E-02	1.05E-02	1.19E-02	7.55E-03	1.60E-03	-4.30E-03	-9.38E-03	-1.34E-02	-1.63E-02	-1.78E-02

Low	1	2	3	4	5	6	7	8	9	10
1	7.47E-02	5.40E-02	3.99E-02	2.92E-02	2.07E-02	1.36E-02	7.47E-03	2.00E-03	-3.16E-03	-8.37E-03
2	-2.83E-02	-1.82E-02	-1.40E-02	-1.15E-02	-9.46E-03	-7.63E-03	-5.79E-03	-4.13E-03	-2.78E-03	-1.97E-03
3	-3.85E-02	-2.42E-02	-1.80E-02	-1.38E-02	-1.02E-02	-6.56E-03	-2.83E-03	7.80E-04	4.14E-03	6.98E-03
4	-1.60E-02	-4.64E-03	-2.28E-03	-1.55E-03	-7.80E-04	4.66E-04	2.20E-03	4.15E-03	6.10E-03	7.76E-03
5	8.74E-03	1.61E-02	1.31E-02	8.55E-03	4.43E-03	1.12E-03	-1.35E-03	-3.32E-03	-5.02E-03	-6.79E-03

High	1	2	3	4	5	6	7	8	9	10
6	7.07E-03	1.20E-02	6.85E-03	1.30E-03	-2.58E-03	-4.38E-03	-4.19E-03	-2.42E-03	5.52E-04	4.26E-03
7	-5.07E-03	5.57E-03	3.51E-03	-2.91E-04	-3.25E-03	-4.67E-03	-4.47E-03	-2.97E-03	-4.52E-04	2.65E-03
8	-1.13E-02	4.06E-03	4.44E-03	1.86E-03	-6.43E-04	-2.12E-03	-2.32E-03	-1.50E-03	1.37E-04	2.21E-03
9	-1.55E-02	3.91E-03	6.35E-03	4.71E-03	2.43E-03	6.63E-04	-1.86E-04	-2.87E-04	2.05E-04	9.76E-04
10	-2.03E-02	2.72E-03	7.06E-03	6.20E-03	4.01E-03	1.85E-03	2.14E-04	-9.46E-04	-1.74E-03	-2.42E-03

1 MeV Al-SS Dose (Fractional Difference)

Full	1	2	3	4	5	6	7	8	9	10
1	2.34E-01	1.71E-01	1.28E-01	9.72E-02	7.28E-02	5.30E-02	3.65E-02	2.24E-02	1.01E-02	-1.05E-03
2	4.33E-02	3.46E-02	2.57E-02	1.78E-02	1.09E-02	5.03E-03	-1.53E-04	-4.79E-03	-9.02E-03	-1.31E-02
3	-3.47E-02	-2.54E-02	-2.12E-02	-1.89E-02	-1.73E-02	-1.60E-02	-1.49E-02	-1.41E-02	-1.33E-02	-1.30E-02
4	-5.74E-02	-4.32E-02	-3.50E-02	-2.90E-02	-2.40E-02	-1.96E-02	-1.55E-02	-1.18E-02	-8.49E-03	-5.68E-03
5	-5.23E-02	-3.83E-02	-3.02E-02	-2.40E-02	-1.85E-02	-1.33E-02	-8.46E-03	-3.87E-03	4.21E-04	4.21E-03
6	-3.49E-02	-2.31E-02	-1.70E-02	-1.23E-02	-7.91E-03	-3.58E-03	6.64E-04	4.82E-03	8.82E-03	1.24E-02
7	-1.51E-02	-5.94E-03	-2.48E-03	-1.25E-04	2.19E-03	4.75E-03	7.46E-03	1.03E-02	1.31E-02	1.56E-02
8	1.18E-03	7.72E-03	8.35E-03	8.04E-03	7.90E-03	8.20E-03	8.84E-03	9.74E-03	1.08E-02	1.17E-02
9	1.04E-02	1.46E-02	1.26E-02	9.64E-03	6.93E-03	4.79E-03	3.12E-03	1.83E-03	7.99E-04	-2.38E-04
10	1.11E-02	1.33E-02	8.89E-03	3.47E-03	-1.67E-03	-6.19E-03	-1.02E-02	-1.37E-02	-1.69E-02	-2.00E-02

Low	1	2	3	4	5	6	7	8	9	10
1	6.90E-02	5.09E-02	3.82E-02	2.80E-02	1.96E-02	1.24E-02	6.13E-03	4.71E-04	-4.80E-03	-1.00E-02
2	-3.12E-02	-2.00E-02	-1.41E-02	-1.04E-02	-7.76E-03	-5.71E-03	-4.11E-03	-2.91E-03	-2.12E-03	-1.92E-03
3	-3.80E-02	-2.56E-02	-1.84E-02	-1.31E-02	-8.58E-03	-4.55E-03	-9.57E-04	2.23E-03	4.98E-03	7.04E-03
4	-1.12E-02	-5.61E-03	-3.73E-03	-2.36E-03	-8.53E-04	9.07E-04	2.75E-03	4.58E-03	6.24E-03	7.45E-03
5	1.86E-02	1.60E-02	1.07E-02	6.00E-03	2.37E-03	-2.75E-04	-2.26E-03	-3.81E-03	-5.14E-03	-6.59E-03

High	1	2	3	4	5	6	7	8	9	10
6	6.66E-03	6.91E-03	3.94E-03	1.48E-03	2.73E-05	-5.13E-04	-5.07E-04	-2.30E-04	2.68E-05	-1.47E-04
7	-3.35E-03	-9.50E-05	-1.12E-03	-2.19E-03	-2.57E-03	-2.23E-03	-1.50E-03	-5.87E-04	2.18E-04	5.40E-04
8	-5.57E-03	-6.32E-04	-8.21E-04	-1.44E-03	-1.58E-03	-1.16E-03	-4.04E-04	4.60E-04	1.19E-03	1.42E-03
9	-4.52E-03	1.39E-03	1.43E-03	7.14E-04	2.66E-04	2.91E-04	5.80E-04	9.40E-04	1.16E-03	8.81E-04
10	-3.19E-03	3.27E-03	3.21E-03	2.06E-03	1.01E-03	3.24E-04	-1.71E-04	-6.13E-04	-1.20E-03	-2.28E-03

2 MeV Al-SS Dose (Fractional Difference)

Full	1	2	3	4	5	6	7	8	9	10
1	2.02E-01	1.46E-01	1.09E-01	8.15E-02	5.95E-02	4.13E-02	2.59E-02	1.26E-02	1.14E-03	-9.05E-03
2	3.37E-02	2.79E-02	2.17E-02	1.56E-02	9.63E-03	3.99E-03	-1.29E-03	-6.18E-03	-1.07E-02	-1.49E-02
3	-3.71E-02	-2.56E-02	-1.91E-02	-1.53E-02	-1.31E-02	-1.19E-02	-1.14E-02	-1.13E-02	-1.14E-02	-1.17E-02
4	-5.79E-02	-4.20E-02	-3.14E-02	-2.39E-02	-1.83E-02	-1.39E-02	-1.05E-02	-7.77E-03	-5.49E-03	-3.60E-03
5	-5.24E-02	-3.76E-02	-2.75E-02	-1.97E-02	-1.35E-02	-8.39E-03	-4.10E-03	-4.04E-04	2.85E-03	5.69E-03
6	-3.45E-02	-2.34E-02	-1.58E-02	-9.78E-03	-4.75E-03	-4.25E-04	3.38E-03	6.80E-03	9.95E-03	1.28E-02
7	-1.33E-02	-6.84E-03	-2.85E-03	3.63E-04	3.22E-03	5.83E-03	8.28E-03	1.06E-02	1.29E-02	1.50E-02
8	5.09E-03	6.77E-03	6.84E-03	6.85E-03	7.06E-03	7.45E-03	8.05E-03	8.82E-03	9.75E-03	1.07E-02
9	1.70E-02	1.42E-02	1.05E-02	7.32E-03	4.79E-03	2.81E-03	1.36E-03	4.54E-04	-2.43E-04	-6.79E-04
10	2.05E-02	1.40E-02	6.95E-03	7.85E-04	-4.23E-03	-8.48E-03	-1.20E-02	-1.48E-02	-1.72E-02	-1.91E-02

Low	1	2	3	4	5	6	7	8	9	10
1	6.00E-02	4.35E-02	3.22E-02	2.32E-02	1.56E-02	9.01E-03	3.27E-03	-1.76E-03	-6.16E-03	-1.01E-02
2	-2.96E-02	-1.87E-02	-1.22E-02	-8.28E-03	-5.76E-03	-4.11E-03	-2.98E-03	-2.15E-03	-1.48E-03	-9.77E-04
3	-3.54E-02	-2.34E-02	-1.57E-02	-1.01E-02	-5.81E-03	-2.38E-03	5.09E-04	3.03E-03	5.30E-03	7.32E-03
4	-9.49E-03	-5.32E-03	-3.02E-03	-1.32E-03	1.85E-04	1.58E-03	2.95E-03	4.34E-03	5.75E-03	7.14E-03
5	1.99E-02	1.43E-02	8.89E-03	4.56E-03	1.24E-03	-1.31E-03	-3.21E-03	-4.58E-03	-5.50E-03	-6.13E-03

High	1	2	3	4	5	6	7	8	9	10
6	5.00E-03	4.43E-03	3.14E-03	2.16E-03	1.50E-03	9.84E-04	4.82E-04	-1.10E-04	-8.71E-04	-1.98E-03
7	-3.52E-03	-2.29E-03	-2.12E-03	-1.83E-03	-1.33E-03	-7.92E-04	-2.90E-04	4.80E-05	1.52E-04	-1.46E-04
8	-4.02E-03	-2.55E-03	-2.24E-03	-1.79E-03	-1.11E-03	-3.58E-04	3.80E-04	9.76E-04	1.34E-03	1.31E-03
9	-7.87E-04	4.33E-05	-2.79E-04	-3.75E-04	-1.37E-04	2.55E-04	7.04E-04	1.19E-03	1.35E-03	1.18E-03
10	3.13E-03	2.87E-03	1.48E-03	4.34E-04	-5.05E-05	-3.87E-04	-5.82E-04	-7.92E-04	-1.13E-03	-1.72E-03

6 MeV Al-SS Dose (Fractional Difference)

Full	1	2	3	4	5	6	7	8	9	10
1	1.35E-01	1.16E-01	9.82E-02	7.97E-02	6.11E-02	4.32E-02	2.65E-02	1.14E-02	-1.99E-03	-1.35E-02
2	1.53E-02	2.53E-02	2.75E-02	2.43E-02	1.79E-02	9.94E-03	1.59E-03	-6.41E-03	-1.36E-02	-1.96E-02
3	-3.93E-02	-1.88E-02	-7.91E-03	-3.61E-03	-3.43E-03	-5.51E-03	-8.66E-03	-1.20E-02	-1.49E-02	-1.70E-02
4	-5.76E-02	-3.50E-02	-2.11E-02	-1.36E-02	-1.02E-02	-9.11E-03	-9.20E-03	-9.58E-03	-9.67E-03	-9.05E-03
5	-5.43E-02	-3.38E-02	-2.05E-02	-1.26E-02	-8.15E-03	-5.72E-03	-4.26E-03	-3.05E-03	-1.26E-03	1.10E-03
6	-3.86E-02	-2.30E-02	-1.24E-02	-5.85E-03	-2.05E-03	5.33E-04	2.32E-03	4.19E-03	6.87E-03	1.03E-02
7	-1.76E-02	-8.49E-03	-1.92E-03	1.88E-03	4.07E-03	5.72E-03	7.09E-03	8.89E-03	1.18E-02	1.56E-02
8	2.66E-03	4.74E-03	6.20E-03	6.65E-03	6.77E-03	6.66E-03	7.02E-03	8.45E-03	1.08E-02	1.48E-02
9	1.77E-02	1.25E-02	8.79E-03	5.60E-03	3.11E-03	1.13E-03	1.45E-04	6.10E-04	2.29E-03	5.79E-03
10	2.43E-02	1.21E-02	3.54E-03	-3.22E-03	-8.34E-03	-1.23E-02	-1.48E-02	-1.55E-02	-1.47E-02	-1.20E-02

Low	1	2	3	4	5	6	7	8	9	10
1	4.00E-02	3.28E-02	2.79E-02	2.24E-02	1.63E-02	9.92E-03	3.67E-03	-2.10E-03	-7.24E-03	-1.16E-02
2	-2.73E-02	-1.64E-02	-8.87E-03	-4.60E-03	-2.62E-03	-2.02E-03	-2.16E-03	-2.50E-03	-2.71E-03	-2.58E-03
3	-3.08E-02	-2.06E-02	-1.26E-02	-7.15E-03	-3.54E-03	-1.05E-03	8.18E-04	2.54E-03	4.39E-03	6.59E-03
4	-7.36E-03	-5.50E-03	-2.88E-03	-9.20E-04	4.32E-04	1.53E-03	2.60E-03	3.93E-03	5.70E-03	8.04E-03
5	2.12E-02	1.18E-02	6.43E-03	2.53E-03	-4.98E-04	-2.73E-03	-4.23E-03	-4.97E-03	-4.66E-03	-3.68E-03

High	1	2	3	4	5	6	7	8	9	10
6	1.56E-03	2.10E-03	3.53E-03	4.19E-03	3.89E-03	3.09E-03	1.58E-03	-2.38E-04	-1.95E-03	-3.90E-03
7	-4.63E-03	-4.11E-03	-2.01E-03	-5.45E-04	2.34E-04	6.39E-04	3.85E-04	-1.50E-04	-5.96E-04	-1.29E-03
8	-3.48E-03	-4.09E-03	-2.83E-03	-1.51E-03	-3.16E-04	2.80E-04	5.90E-04	9.47E-04	1.00E-03	1.30E-03
9	1.69E-03	-1.20E-03	-1.39E-03	-9.43E-04	-2.23E-04	1.97E-04	5.34E-04	1.07E-03	1.41E-03	2.07E-03
10	8.00E-03	2.26E-03	5.12E-05	-8.98E-04	-1.13E-03	-1.34E-03	-1.39E-03	-1.06E-03	-7.90E-04	-9.49E-05

10 MeV Al-SS Dose (Fractional Difference)

Full	1	2	3	4	5	6	7	8	9	10
1	9.79E-02	9.38E-02	8.72E-02	7.66E-02	6.33E-02	4.87E-02	3.38E-02	1.94E-02	6.03E-03	-5.82E-03
2	5.39E-03	1.98E-02	2.60E-02	2.56E-02	2.08E-02	1.36E-02	5.17E-03	-3.38E-03	-1.13E-02	-1.81E-02
3	-3.77E-02	-1.69E-02	-5.10E-03	-5.19E-04	-6.59E-04	-3.57E-03	-7.85E-03	-1.25E-02	-1.66E-02	-1.96E-02
4	-5.25E-02	-3.05E-02	-1.71E-02	-1.04E-02	-8.22E-03	-8.67E-03	-1.04E-02	-1.23E-02	-1.38E-02	-1.39E-02
5	-4.98E-02	-2.97E-02	-1.68E-02	-9.92E-03	-7.02E-03	-6.27E-03	-6.46E-03	-6.62E-03	-6.20E-03	-4.15E-03
6	-3.64E-02	-2.01E-02	-9.66E-03	-3.89E-03	-1.29E-03	-3.62E-04	6.52E-05	6.67E-04	2.61E-03	6.28E-03
7	-1.82E-02	-7.20E-03	-1.44E-04	3.48E-03	4.85E-03	5.21E-03	5.59E-03	6.58E-03	9.27E-03	1.40E-02
8	-1.56E-04	4.56E-03	7.41E-03	8.21E-03	7.73E-03	6.97E-03	6.79E-03	7.65E-03	1.06E-02	1.59E-02
9	1.31E-02	1.10E-02	9.25E-03	6.85E-03	4.16E-03	1.92E-03	7.93E-04	1.13E-03	3.86E-03	9.28E-03
10	1.76E-02	8.91E-03	2.46E-03	-3.22E-03	-8.26E-03	-1.22E-02	-1.45E-02	-1.50E-02	-1.28E-02	-7.81E-03

Low	1	2	3	4	5	6	7	8	9	10
1	2.82E-02	2.54E-02	2.45E-02	2.18E-02	1.74E-02	1.17E-02	5.59E-03	-5.67E-04	-6.25E-03	-1.11E-02
2	-2.45E-02	-1.48E-02	-7.07E-03	-2.70E-03	-9.67E-04	-9.59E-04	-1.87E-03	-3.08E-03	-4.01E-03	-4.27E-03
3	-2.71E-02	-1.84E-02	-1.07E-02	-5.63E-03	-2.59E-03	-8.61E-04	2.31E-04	1.26E-03	2.75E-03	5.10E-03
4	-6.81E-03	-5.44E-03	-2.53E-03	-4.93E-04	6.58E-04	1.35E-03	2.06E-03	3.19E-03	5.08E-03	8.28E-03
5	1.91E-02	1.00E-02	5.52E-03	2.15E-03	-7.06E-04	-2.89E-03	-4.31E-03	-4.69E-03	-4.02E-03	-1.61E-03

High	1	2	3	4	5	6	7	8	9	10
6	-1.04E-04	6.51E-04	2.97E-03	4.51E-03	4.77E-03	3.97E-03	2.43E-03	2.64E-04	-1.82E-03	-3.79E-03
7	-4.77E-03	-4.59E-03	-2.24E-03	-2.50E-04	7.66E-04	9.43E-04	5.45E-04	-3.63E-04	-1.10E-03	-1.65E-03
8	-2.93E-03	-4.38E-03	-2.90E-03	-1.24E-03	-1.59E-04	3.72E-04	5.54E-04	3.89E-04	5.32E-04	9.85E-04
9	2.47E-03	-1.40E-03	-1.48E-03	-7.56E-04	-1.71E-04	2.00E-04	4.80E-04	6.21E-04	1.23E-03	2.31E-03
10	8.89E-03	2.02E-03	-1.45E-04	-8.57E-04	-1.23E-03	-1.45E-03	-1.48E-03	-1.43E-03	-7.04E-04	6.06E-04

Stainless Steel followed by Aluminum

65 keV SS-Al Dose (Fractional Difference)

Full	1	2	3	4	5	6	7	8	9	10
1	2.34E-02	2.90E-02	3.67E-02	3.91E-02	3.62E-02	2.94E-02	2.00E-02	9.07E-03	-2.48E-03	-1.39E-02
2	-1.41E-02	-2.26E-03	1.03E-02	1.71E-02	1.83E-02	1.53E-02	9.63E-03	2.37E-03	-5.63E-03	-1.35E-02
3	-3.26E-02	-1.99E-02	-5.64E-03	3.26E-03	6.95E-03	6.67E-03	3.74E-03	-6.61E-04	-5.70E-03	-1.06E-02
4	-3.83E-02	-2.80E-02	-1.41E-02	-4.53E-03	4.51E-04	1.90E-03	1.02E-03	-1.14E-03	-3.75E-03	-5.95E-03
5	-3.45E-02	-2.88E-02	-1.70E-02	-7.92E-03	-2.60E-03	-2.13E-04	2.29E-04	-2.58E-04	-8.96E-04	-8.62E-04
6	-2.34E-02	-2.43E-02	-1.57E-02	-8.20E-03	-3.36E-03	-7.62E-04	4.60E-04	1.11E-03	1.96E-03	3.82E-03
7	-6.86E-03	-1.58E-02	-1.16E-02	-6.51E-03	-2.89E-03	-6.90E-04	6.41E-04	1.92E-03	3.78E-03	7.01E-03
8	1.34E-02	-4.76E-03	-5.77E-03	-3.89E-03	-2.17E-03	-1.01E-03	-6.77E-05	1.32E-03	3.69E-03	7.82E-03
9	3.62E-02	7.76E-03	7.34E-04	-1.22E-03	-1.98E-03	-2.41E-03	-2.32E-03	-1.35E-03	1.04E-03	5.52E-03
10	5.98E-02	2.05E-02	6.86E-03	5.33E-04	-3.22E-03	-5.69E-03	-7.06E-03	-6.99E-03	-5.12E-03	-8.17E-04

Low	1	2	3	4	5	6	7	8	9	10
1	4.31E-03	3.28E-03	9.50E-03	1.32E-02	1.35E-02	1.11E-02	6.90E-03	1.98E-03	-3.02E-03	-7.35E-03
2	-1.70E-02	-1.56E-02	-6.97E-03	-6.32E-04	2.46E-03	2.98E-03	1.91E-03	1.89E-04	-1.48E-03	-2.30E-03
3	-1.38E-02	-1.75E-02	-1.11E-02	-5.32E-03	-1.87E-03	-3.46E-04	3.31E-05	1.29E-04	6.05E-04	2.23E-03
4	6.11E-03	-7.70E-03	-6.71E-03	-4.05E-03	-2.22E-03	-1.34E-03	-8.98E-04	-2.49E-04	1.20E-03	4.19E-03
5	3.73E-02	9.87E-03	2.90E-03	5.51E-04	-8.82E-04	-2.08E-03	-2.93E-03	-2.94E-03	-1.65E-03	1.56E-03

High	1	2	3	4	5	6	7	8	9	10
6	-9.54E-03	-8.81E-03	-6.78E-04	5.06E-03	7.35E-03	6.85E-03	4.60E-03	1.49E-03	-1.67E-03	-4.04E-03
7	-6.52E-03	-1.02E-02	-4.06E-03	9.47E-04	3.31E-03	3.46E-03	2.17E-03	3.89E-04	-1.17E-03	-1.67E-03
8	9.09E-04	-8.16E-03	-4.79E-03	-1.09E-03	8.61E-04	1.18E-03	5.20E-04	-2.58E-04	-5.02E-04	6.14E-04
9	1.18E-02	-3.51E-03	-3.52E-03	-1.65E-03	-5.71E-04	-4.79E-04	-7.87E-04	-8.96E-04	-1.13E-04	2.34E-03
10	2.52E-02	2.85E-03	-1.09E-03	-1.51E-03	-1.70E-03	-2.15E-03	-2.56E-03	-2.31E-03	-8.14E-04	2.69E-03

100 keV SS-Al Dose (Fractional Difference)

Full	1	2	3	4	5	6	7	8	9	10
1	2.84E-02	6.23E-02	7.89E-02	8.21E-02	7.62E-02	6.41E-02	4.77E-02	2.84E-02	7.04E-03	-1.58E-02
2	-5.13E-02	-5.19E-03	2.13E-02	3.35E-02	3.57E-02	3.12E-02	2.19E-02	9.23E-03	-5.91E-03	-2.30E-02
3	-8.43E-02	-3.96E-02	-1.09E-02	4.92E-03	1.16E-02	1.19E-02	7.60E-03	-9.08E-05	-1.03E-02	-2.25E-02
4	-8.94E-02	-5.29E-02	-2.66E-02	-1.03E-02	-1.47E-03	1.76E-03	9.42E-04	-2.89E-03	-9.04E-03	-1.71E-02
5	-7.59E-02	-5.18E-02	-3.06E-02	-1.59E-02	-6.81E-03	-2.01E-03	-4.48E-04	-1.36E-03	-4.17E-03	-8.66E-03
6	-4.98E-02	-4.08E-02	-2.68E-02	-1.54E-02	-7.33E-03	-2.13E-03	8.26E-04	2.04E-03	1.89E-03	5.01E-04
7	-1.52E-02	-2.35E-02	-1.82E-02	-1.14E-02	-5.56E-03	-9.66E-04	2.50E-03	5.05E-03	6.87E-03	7.97E-03
8	2.40E-02	-2.86E-03	-7.53E-03	-6.48E-03	-3.78E-03	-7.32E-04	2.36E-03	5.38E-03	8.41E-03	1.13E-02
9	6.43E-02	1.83E-02	2.84E-03	-2.64E-03	-4.04E-03	-3.40E-03	-1.56E-03	1.12E-03	4.48E-03	8.26E-03
10	1.03E-01	3.74E-02	1.08E-02	-1.89E-03	-8.04E-03	-1.06E-02	-1.09E-02	-9.47E-03	-6.74E-03	-3.08E-03

Low	1	2	3	4	5	6	7	8	9	10
1	-6.41E-03	9.47E-03	2.14E-02	2.64E-02	2.60E-02	2.20E-02	1.54E-02	7.02E-03	-2.47E-03	-1.29E-02
2	-4.85E-02	-2.93E-02	-1.30E-02	-2.87E-03	2.33E-03	4.03E-03	3.35E-03	1.03E-03	-2.36E-03	-6.56E-03
3	-3.55E-02	-3.02E-02	-1.96E-02	-1.13E-02	-5.65E-03	-2.17E-03	-1.50E-04	9.47E-04	1.52E-03	1.71E-03
4	9.54E-03	-8.48E-03	-9.83E-03	-7.93E-03	-5.60E-03	-3.42E-03	-1.32E-03	8.75E-04	3.33E-03	6.04E-03
5	7.22E-02	2.55E-02	8.27E-03	5.63E-04	-3.16E-03	-4.77E-03	-4.90E-03	-3.82E-03	-1.61E-03	1.57E-03

High	1	2	3	4	5	6	7	8	9	10
6	-3.36E-02	-1.64E-02	-1.21E-03	7.89E-03	1.17E-02	1.16E-02	8.87E-03	4.35E-03	-1.21E-03	-7.41E-03
7	-2.20E-02	-1.62E-02	-6.10E-03	9.47E-04	4.47E-03	5.25E-03	4.14E-03	1.84E-03	-1.06E-03	-4.21E-03
8	-3.31E-03	-1.02E-02	-6.31E-03	-2.27E-03	2.46E-04	1.23E-03	1.21E-03	6.13E-04	-3.81E-06	-3.65E-04
9	2.01E-02	-4.74E-04	-3.58E-03	-3.19E-03	-2.41E-03	-1.80E-03	-1.27E-03	-5.44E-04	7.16E-04	2.71E-03
10	4.60E-02	1.12E-02	5.20E-04	-3.36E-03	-4.79E-03	-5.10E-03	-4.52E-03	-3.00E-03	-3.16E-04	3.63E-03

500 keV SS-Al Dose (Fractional Difference)

Full	1	2	3	4	5	6	7	8	9	10
1	1.79E-01	1.88E-01	1.80E-01	1.62E-01	1.39E-01	1.12E-01	8.40E-02	5.46E-02	2.41E-02	-7.28E-03
2	-3.19E-03	3.39E-02	5.08E-02	5.52E-02	5.15E-02	4.23E-02	2.91E-02	1.26E-02	-6.63E-03	-2.84E-02
3	-7.49E-02	-3.86E-02	-1.55E-02	-2.16E-03	3.90E-03	4.44E-03	4.82E-04	-7.39E-03	-1.88E-02	-3.37E-02
4	-9.05E-02	-6.44E-02	-4.32E-02	-2.76E-02	-1.72E-02	-1.14E-02	-9.63E-03	-1.18E-02	-1.78E-02	-2.77E-02
5	-7.54E-02	-6.28E-02	-4.71E-02	-3.28E-02	-2.13E-02	-1.29E-02	-7.85E-03	-6.35E-03	-8.64E-03	-1.50E-02
6	-4.42E-02	-4.61E-02	-3.76E-02	-2.66E-02	-1.59E-02	-6.81E-03	-1.42E-04	3.51E-03	3.60E-03	-3.77E-04
7	-6.83E-03	-2.30E-02	-2.24E-02	-1.58E-02	-7.33E-03	1.05E-03	7.97E-03	1.25E-02	1.38E-02	1.12E-02
8	2.92E-02	-4.12E-04	-8.02E-03	-6.50E-03	-1.14E-03	5.41E-03	1.14E-02	1.56E-02	1.71E-02	1.48E-02
9	5.86E-02	1.64E-02	8.35E-04	-3.13E-03	-1.64E-03	2.16E-03	6.22E-03	9.09E-03	9.63E-03	6.80E-03
10	7.73E-02	2.40E-02	7.82E-04	-8.83E-03	-1.17E-02	-1.14E-02	-1.01E-02	-9.44E-03	-1.07E-02	-1.48E-02

Low	1	2	3	4	5	6	7	8	9	10
1	1.90E-02	4.17E-02	4.88E-02	4.73E-02	4.12E-02	3.25E-02	2.19E-02	9.83E-03	-3.62E-03	-1.87E-02
2	-6.24E-02	-3.52E-02	-1.83E-02	-8.06E-03	-2.25E-03	5.38E-04	9.37E-04	-7.89E-04	-4.70E-03	-1.11E-02
3	-4.61E-02	-3.79E-02	-2.81E-02	-1.92E-02	-1.17E-02	-5.48E-03	-6.56E-04	2.53E-03	3.70E-03	2.36E-03
4	8.11E-03	-8.73E-03	-1.25E-02	-1.10E-02	-7.35E-03	-2.74E-03	1.89E-03	5.83E-03	8.37E-03	8.75E-03
5	6.80E-02	2.61E-02	7.03E-03	-1.67E-03	-4.91E-03	-5.17E-03	-4.02E-03	-2.57E-03	-1.79E-03	-2.62E-03

High	1	2	3	4	5	6	7	8	9	10
6	-2.24E-02	-6.65E-03	5.38E-03	1.21E-02	1.42E-02	1.29E-02	9.16E-03	3.69E-03	-2.90E-03	-1.02E-02
7	-1.86E-02	-1.29E-02	-4.91E-03	9.01E-04	3.98E-03	4.73E-03	3.63E-03	1.19E-03	-2.16E-03	-6.15E-03
8	-4.73E-03	-9.70E-03	-6.94E-03	-3.24E-03	-4.17E-04	1.24E-03	1.78E-03	1.48E-03	5.72E-04	-7.77E-04
9	1.39E-02	-1.95E-03	-5.00E-03	-4.23E-03	-2.54E-03	-8.55E-04	5.18E-04	1.58E-03	2.41E-03	3.07E-03
10	3.29E-02	6.27E-03	-2.87E-03	-5.56E-03	-5.66E-03	-4.64E-03	-3.15E-03	-1.41E-03	5.00E-04	2.54E-03

1 MeV SS-Al Dose (Fractional Difference)

Full	1	2	3	4	5	6	7	8	9	10
1	2.31E-01	1.83E-01	1.48E-01	1.19E-01	9.34E-02	7.05E-02	4.94E-02	2.94E-02	9.94E-03	-9.29E-03
2	3.63E-02	3.59E-02	3.41E-02	3.00E-02	2.43E-02	1.73E-02	9.17E-03	-2.36E-05	-1.03E-02	-2.18E-02
3	-4.27E-02	-3.10E-02	-2.09E-02	-1.40E-02	-9.90E-03	-8.23E-03	-8.68E-03	-1.11E-02	-1.55E-02	-2.18E-02
4	-6.43E-02	-5.33E-02	-4.07E-02	-2.98E-02	-2.14E-02	-1.54E-02	-1.16E-02	-1.01E-02	-1.08E-02	-1.38E-02
5	-5.57E-02	-5.05E-02	-3.97E-02	-2.88E-02	-1.93E-02	-1.16E-02	-5.90E-03	-2.41E-03	-1.20E-03	-2.44E-03
6	-3.26E-02	-3.51E-02	-2.82E-02	-1.93E-02	-1.06E-02	-3.08E-03	2.84E-03	6.84E-03	8.67E-03	8.12E-03
7	-5.16E-03	-1.57E-02	-1.38E-02	-8.00E-03	-1.39E-03	4.77E-03	9.79E-03	1.32E-02	1.47E-02	1.40E-02
8	1.97E-02	1.32E-03	-1.89E-03	1.58E-04	3.99E-03	8.00E-03	1.13E-02	1.34E-02	1.39E-02	1.23E-02
9	3.75E-02	1.20E-02	3.74E-03	1.89E-03	2.58E-03	4.00E-03	5.16E-03	5.42E-03	4.32E-03	1.46E-03
10	4.56E-02	1.39E-02	9.91E-04	-4.65E-03	-7.17E-03	-8.53E-03	-9.76E-03	-1.16E-02	-1.44E-02	-1.88E-02

Low	1	2	3	4	5	6	7	8	9	10
1	5.29E-02	4.94E-02	4.35E-02	3.58E-02	2.74E-02	1.90E-02	1.07E-02	2.41E-03	-5.87E-03	-1.44E-02
2	-4.16E-02	-2.57E-02	-1.51E-02	-8.69E-03	-4.85E-03	-2.74E-03	-1.87E-03	-2.05E-03	-3.20E-03	-5.42E-03
3	-3.91E-02	-3.14E-02	-2.25E-02	-1.50E-02	-8.84E-03	-3.87E-03	5.53E-05	2.96E-03	4.80E-03	5.44E-03
4	-7.99E-04	-8.85E-03	-8.70E-03	-6.22E-03	-3.05E-03	1.58E-04	3.12E-03	5.56E-03	7.27E-03	8.00E-03
5	4.14E-02	1.67E-02	6.15E-03	1.11E-03	-1.29E-03	-2.38E-03	-2.83E-03	-3.15E-03	-3.70E-03	-4.84E-03

High	1	2	3	4	5	6	7	8	9	10
6	-3.21E-03	-1.97E-04	4.80E-03	7.65E-03	8.11E-03	6.74E-03	4.13E-03	7.95E-04	-2.86E-03	-6.59E-03
7	-7.58E-03	-8.09E-03	-3.81E-03	-2.59E-04	1.67E-03	2.13E-03	1.52E-03	2.57E-04	-1.34E-03	-3.04E-03
8	-2.17E-03	-7.58E-03	-5.44E-03	-2.52E-03	-3.61E-04	8.38E-04	1.28E-03	1.23E-03	9.57E-04	6.25E-04
9	7.83E-03	-3.12E-03	-3.92E-03	-2.50E-03	-9.42E-04	2.19E-04	9.91E-04	1.51E-03	1.97E-03	2.47E-03
10	1.83E-02	1.64E-03	-2.51E-03	-3.09E-03	-2.68E-03	-2.11E-03	-1.53E-03	-9.41E-04	-2.28E-04	6.67E-04

2 MeV SS-Al Dose (Fractional Difference)

Full	1	2	3	4	5	6	7	8	9	10
1	1.99E-01	1.42E-01	1.05E-01	7.85E-02	5.77E-02	4.06E-02	2.62E-02	1.36E-02	2.38E-03	-7.85E-03
2	3.08E-02	2.32E-02	1.77E-02	1.27E-02	7.97E-03	3.39E-03	-1.06E-03	-5.46E-03	-9.88E-03	-1.44E-02
3	-3.70E-02	-2.89E-02	-2.21E-02	-1.73E-02	-1.41E-02	-1.21E-02	-1.10E-02	-1.06E-02	-1.09E-02	-1.19E-02
4	-5.45E-02	-4.35E-02	-3.32E-02	-2.50E-02	-1.86E-02	-1.36E-02	-9.83E-03	-7.10E-03	-5.28E-03	-4.32E-03
5	-4.63E-02	-3.77E-02	-2.81E-02	-1.99E-02	-1.31E-02	-7.58E-03	-3.13E-03	3.23E-04	2.87E-03	4.58E-03
6	-2.69E-02	-2.29E-02	-1.61E-02	-9.63E-03	-4.08E-03	6.02E-04	4.47E-03	7.52E-03	9.80E-03	1.13E-02
7	-5.55E-03	-6.70E-03	-3.43E-03	3.17E-04	3.79E-03	6.82E-03	9.34E-03	1.13E-02	1.27E-02	1.35E-02
8	1.18E-02	5.71E-03	5.31E-03	6.14E-03	7.20E-03	8.21E-03	9.03E-03	9.53E-03	9.72E-03	9.42E-03
9	2.18E-02	1.14E-02	7.62E-03	5.66E-03	4.33E-03	3.27E-03	2.28E-03	1.23E-03	3.80E-05	-1.46E-03
10	2.29E-02	9.04E-03	2.42E-03	-2.01E-03	-5.49E-03	-8.46E-03	-1.11E-02	-1.37E-02	-1.62E-02	-1.89E-02

Low	1	2	3	4	5	6	7	8	9	10
1	5.73E-02	4.23E-02	3.18E-02	2.30E-02	1.55E-02	8.94E-03	3.23E-03	-1.81E-03	-6.26E-03	-1.03E-02
2	-3.04E-02	-1.96E-02	-1.24E-02	-8.03E-03	-5.34E-03	-3.66E-03	-2.58E-03	-1.89E-03	-1.45E-03	-1.22E-03
3	-3.35E-02	-2.38E-02	-1.58E-02	-9.80E-03	-5.34E-03	-1.86E-03	9.61E-04	3.30E-03	5.28E-03	6.94E-03
4	-5.98E-03	-5.89E-03	-3.65E-03	-1.54E-03	2.47E-04	1.81E-03	3.24E-03	4.53E-03	5.74E-03	6.83E-03
5	2.34E-02	1.24E-02	6.98E-03	3.29E-03	5.27E-04	-1.57E-03	-3.15E-03	-4.35E-03	-5.24E-03	-5.90E-03

High	1	2	3	4	5	6	7	8	9	10
6	3.29E-03	1.74E-03	2.69E-03	3.17E-03	2.96E-03	2.22E-03	1.16E-03	-1.16E-04	-1.48E-03	-2.84E-03
7	-2.93E-03	-4.38E-03	-2.64E-03	-1.12E-03	-2.06E-04	1.90E-04	2.25E-04	1.47E-05	-3.52E-04	-7.67E-04
8	-1.61E-03	-4.30E-03	-2.99E-03	-1.50E-03	-4.06E-04	3.06E-04	7.39E-04	9.46E-04	1.08E-03	1.07E-03
9	2.87E-03	-1.72E-03	-1.49E-03	-6.48E-04	5.96E-05	5.62E-04	8.98E-04	1.12E-03	1.29E-03	1.37E-03
10	7.31E-03	6.30E-04	-5.24E-04	-6.61E-04	-6.58E-04	-6.71E-04	-7.16E-04	-7.93E-04	-8.28E-04	-8.94E-04

6 MeV SS-Al Dose (Fractional Difference)

Full	1	2	3	4	5	6	7	8	9	10
1	1.07E-01	7.91E-02	5.81E-02	4.15E-02	2.82E-02	1.76E-02	9.57E-03	3.96E-03	6.75E-04	-3.61E-04
2	3.92E-03	8.60E-03	6.96E-03	3.29E-03	-6.57E-04	-4.02E-03	-6.33E-03	-7.16E-03	-6.49E-03	-4.13E-03
3	-3.59E-02	-2.02E-02	-1.43E-02	-1.24E-02	-1.20E-02	-1.18E-02	-1.12E-02	-9.58E-03	-6.76E-03	-2.49E-03
4	-4.23E-02	-2.47E-02	-1.71E-02	-1.37E-02	-1.21E-02	-1.08E-02	-9.16E-03	-6.66E-03	-2.99E-03	2.05E-03
5	-3.26E-02	-1.67E-02	-1.01E-02	-7.47E-03	-6.29E-03	-5.35E-03	-3.91E-03	-1.47E-03	2.11E-03	7.12E-03
6	-1.76E-02	-4.51E-03	1.43E-05	1.09E-03	1.01E-03	9.63E-04	1.55E-03	3.19E-03	6.15E-03	1.06E-02
7	-4.50E-03	6.08E-03	8.59E-03	8.00E-03	6.50E-03	5.20E-03	4.69E-03	5.36E-03	7.41E-03	1.10E-02
8	2.81E-03	1.16E-02	1.27E-02	1.08E-02	8.05E-03	5.63E-03	4.08E-03	3.82E-03	4.92E-03	7.56E-03
9	2.50E-03	1.05E-02	1.08E-02	8.11E-03	4.63E-03	1.39E-03	-9.76E-04	-2.15E-03	-1.93E-03	-1.96E-04
10	-5.69E-03	2.33E-03	2.56E-03	-3.26E-04	-4.16E-03	-7.83E-03	-1.07E-02	-1.25E-02	-1.30E-02	-1.20E-02

Low	1	2	3	4	5	6	7	8	9	10
1	4.18E-02	2.62E-02	1.66E-02	9.96E-03	4.99E-03	1.26E-03	-1.45E-03	-3.25E-03	-4.17E-03	-4.29E-03
2	-1.95E-02	-1.14E-02	-7.89E-03	-6.02E-03	-4.85E-03	-3.88E-03	-2.86E-03	-1.49E-03	1.78E-04	2.28E-03
3	-2.44E-02	-1.26E-02	-7.16E-03	-4.23E-03	-2.37E-03	-8.89E-04	6.03E-04	2.28E-03	4.27E-03	6.68E-03
4	-9.51E-03	-5.80E-04	2.08E-03	2.56E-03	2.34E-03	2.05E-03	2.01E-03	2.39E-03	3.28E-03	4.72E-03
5	4.65E-03	9.35E-03	8.19E-03	5.26E-03	2.05E-03	-8.54E-04	-3.18E-03	-4.74E-03	-5.64E-03	-5.80E-03

High	1	2	3	4	5	6	7	8	9	10
6	6.21E-04	4.14E-03	2.71E-03	2.80E-04	-1.73E-03	-2.80E-03	-2.77E-03	-1.57E-03	8.04E-04	4.31E-03
7	-3.41E-03	2.24E-03	2.10E-03	3.10E-04	-1.51E-03	-2.71E-03	-3.00E-03	-2.24E-03	-4.15E-04	2.48E-03
8	-4.82E-03	2.57E-03	3.45E-03	2.11E-03	3.05E-04	-1.14E-03	-1.85E-03	-1.60E-03	-4.30E-04	1.72E-03
9	-6.42E-03	2.62E-03	4.52E-03	3.67E-03	2.00E-03	3.74E-04	-7.28E-04	-1.08E-03	-5.74E-04	8.46E-04
10	-9.82E-03	9.05E-04	3.94E-03	3.73E-03	2.29E-03	6.22E-04	-7.47E-04	-1.47E-03	-1.51E-03	-7.51E-04

10 MeV SS-Al Dose (Fractional Difference)

Full	1	2	3	4	5	6	7	8	9	10
1	6.91E-02	6.08E-02	4.79E-02	3.46E-02	2.24E-02	1.24E-02	5.20E-03	1.03E-03	1.46E-04	2.67E-03
2	-8.27E-03	8.27E-03	9.64E-03	5.67E-03	3.05E-04	-4.43E-03	-7.47E-03	-8.13E-03	-5.98E-03	-7.79E-04
3	-3.77E-02	-1.32E-02	-6.45E-03	-6.47E-03	-8.73E-03	-1.10E-02	-1.19E-02	-1.06E-02	-6.78E-03	-1.29E-05
4	-4.08E-02	-1.57E-02	-8.22E-03	-7.49E-03	-9.00E-03	-1.05E-02	-1.06E-02	-8.70E-03	-4.16E-03	3.28E-03
5	-3.09E-02	-8.27E-03	-2.20E-03	-2.36E-03	-4.44E-03	-6.23E-03	-6.56E-03	-4.70E-03	-1.83E-04	7.30E-03
6	-1.73E-02	2.28E-03	6.32E-03	4.70E-03	1.56E-03	-1.05E-03	-2.03E-03	-6.90E-04	3.38E-03	1.05E-02
7	-6.24E-03	1.10E-02	1.33E-02	1.04E-02	6.21E-03	2.72E-03	9.86E-04	1.62E-03	5.03E-03	1.15E-02
8	-1.42E-03	1.45E-02	1.60E-02	1.23E-02	7.51E-03	3.32E-03	9.45E-04	9.31E-04	3.66E-03	9.36E-03
9	-4.59E-03	1.13E-02	1.29E-02	9.21E-03	4.24E-03	-1.43E-04	-2.89E-03	-3.38E-03	-1.23E-03	3.77E-03
10	-1.61E-02	8.90E-04	3.46E-03	5.31E-04	-4.00E-03	-8.18E-03	-1.09E-02	-1.17E-02	-9.94E-03	-5.53E-03

Low	1	2	3	4	5	6	7	8	9	10
1	3.56E-02	2.17E-02	1.25E-02	6.16E-03	1.65E-03	-1.38E-03	-3.10E-03	-3.56E-03	-2.80E-03	-8.74E-04
2	-1.57E-02	-7.41E-03	-5.42E-03	-5.05E-03	-5.00E-03	-4.68E-03	-3.80E-03	-2.16E-03	3.78E-04	3.83E-03
3	-2.22E-02	-7.81E-03	-3.31E-03	-1.96E-03	-1.58E-03	-1.28E-03	-5.03E-04	9.91E-04	3.36E-03	6.62E-03
4	-1.30E-02	1.70E-03	5.09E-03	4.79E-03	3.39E-03	1.98E-03	1.15E-03	1.16E-03	2.13E-03	4.11E-03
5	-5.32E-03	8.41E-03	9.91E-03	7.37E-03	3.65E-03	2.45E-05	-2.93E-03	-4.94E-03	-5.87E-03	-5.70E-03

High	1	2	3	4	5	6	7	8	9	10
6	-8.78E-03	6.16E-03	7.24E-03	3.80E-03	-4.30E-04	-3.68E-03	-5.03E-03	-3.92E-03	-6.69E-06	6.92E-03
7	-9.42E-03	5.80E-03	7.08E-03	3.68E-03	-6.38E-04	-4.10E-03	-5.75E-03	-5.02E-03	-1.57E-03	4.84E-03
8	-9.24E-03	6.59E-03	8.33E-03	5.11E-03	7.73E-04	-2.95E-03	-4.93E-03	-4.63E-03	-1.71E-03	4.07E-03
9	-1.07E-02	6.31E-03	8.94E-03	6.23E-03	2.10E-03	-1.58E-03	-3.76E-03	-3.83E-03	-1.40E-03	3.76E-03
10	-1.52E-02	3.54E-03	7.56E-03	5.83E-03	2.26E-03	-1.16E-03	-3.32E-03	-3.59E-03	-1.53E-03	3.09E-03

Polyethylene followed by Stainless Steel

65 keV Poly-SS Dose (Fractional Difference)

Full	1	2	3	4	5	6	7	8	9	10
1	1.27E-01	1.16E-01	8.45E-02	5.78E-02	3.90E-02	2.83E-02	2.52E-02	2.99E-02	4.26E-02	6.40E-02
2	-2.70E-04	3.81E-02	2.78E-02	1.33E-02	1.83E-03	-3.10E-03	-2.11E-03	5.94E-03	2.24E-02	4.67E-02
3	-5.70E-02	2.02E-03	-2.03E-04	-1.02E-02	-1.86E-02	-2.12E-02	-1.81E-02	-8.13E-03	1.03E-02	3.68E-02
4	-7.12E-02	-6.14E-03	-8.02E-03	-1.82E-02	-2.67E-02	-2.90E-02	-2.55E-02	-1.49E-02	4.48E-03	3.23E-02
5	-5.95E-02	3.21E-03	-2.81E-03	-1.59E-02	-2.63E-02	-2.99E-02	-2.71E-02	-1.66E-02	2.89E-03	3.13E-02
6	-3.43E-02	2.14E-02	9.07E-03	-8.27E-03	-2.15E-02	-2.70E-02	-2.55E-02	-1.58E-02	3.35E-03	3.19E-02
7	-7.15E-03	4.02E-02	2.17E-02	2.39E-04	-1.58E-02	-2.34E-02	-2.33E-02	-1.47E-02	3.74E-03	3.19E-02
8	1.05E-02	5.22E-02	2.97E-02	5.45E-03	-1.27E-02	-2.19E-02	-2.32E-02	-1.56E-02	2.03E-03	2.96E-02
9	8.08E-03	5.10E-02	2.86E-02	3.86E-03	-1.50E-02	-2.50E-02	-2.71E-02	-2.04E-02	-3.55E-03	2.32E-02
10	-2.13E-02	3.22E-02	1.51E-02	-7.06E-03	-2.48E-02	-3.44E-02	-3.67E-02	-3.05E-02	-1.43E-02	1.16E-02

Low	1	2	3	4	5	6	7	8	9	10
1	-2.19E-03	2.48E-02	1.88E-02	7.76E-03	-1.74E-03	-7.64E-03	-9.25E-03	-6.02E-03	2.56E-03	1.69E-02
2	-4.25E-02	9.67E-03	1.02E-02	2.50E-03	-5.50E-03	-9.56E-03	-9.92E-03	-5.29E-03	5.54E-03	2.19E-02
3	-3.29E-02	2.00E-02	1.65E-02	5.82E-03	-3.99E-03	-8.97E-03	-9.60E-03	-4.74E-03	6.79E-03	2.42E-02
4	-8.97E-03	3.49E-02	2.35E-02	7.88E-03	-5.00E-03	-1.19E-02	-1.36E-02	-9.28E-03	2.12E-03	1.99E-02
5	-6.62E-03	3.31E-02	1.74E-02	-1.22E-03	-1.60E-02	-2.42E-02	-2.69E-02	-2.32E-02	-1.23E-02	5.10E-03

High	1	2	3	4	5	6	7	8	9	10
6	-6.08E-03	-1.21E-02	-1.00E-02	-5.28E-03	-7.43E-05	7.35E-03	1.61E-02	2.76E-02	4.32E-02	6.20E-02
7	6.67E-04	-1.30E-03	-7.77E-03	-1.07E-02	-1.15E-02	-8.89E-03	-4.00E-03	4.18E-03	1.67E-02	3.28E-02
8	1.03E-03	1.05E-02	-1.96E-04	-8.77E-03	-1.47E-02	-1.64E-02	-1.52E-02	-1.03E-02	-7.17E-04	1.26E-02
9	-2.44E-03	2.18E-02	9.96E-03	-2.44E-03	-1.24E-02	-1.79E-02	-2.01E-02	-1.82E-02	-1.15E-02	-8.03E-04
10	-7.54E-03	3.21E-02	2.13E-02	6.49E-03	-6.62E-03	-1.52E-02	-2.04E-02	-2.13E-02	-1.71E-02	-8.93E-03

100 keV Poly-SS Dose (Fractional Difference)

Full	1	2	3	4	5	6	7	8	9	10
1	1.00E-01	1.20E-01	1.01E-01	7.56E-02	5.08E-02	3.00E-02	1.45E-02	5.16E-03	2.50E-03	7.40E-03
2	-2.21E-02	3.91E-02	4.35E-02	3.22E-02	1.78E-02	4.71E-03	-4.27E-03	-8.10E-03	-6.00E-03	3.75E-03
3	-7.30E-02	1.68E-03	1.38E-02	8.62E-03	-6.36E-04	-9.34E-03	-1.44E-02	-1.48E-02	-8.80E-03	4.74E-03
4	-8.26E-02	-8.12E-03	3.57E-03	-8.38E-04	-8.51E-03	-1.52E-02	-1.81E-02	-1.59E-02	-7.51E-03	9.01E-03
5	-6.72E-02	-6.82E-04	5.70E-03	-1.08E-03	-9.41E-03	-1.58E-02	-1.77E-02	-1.41E-02	-3.83E-03	1.50E-02
6	-3.91E-02	1.55E-02	1.42E-02	3.43E-03	-6.74E-03	-1.37E-02	-1.54E-02	-1.13E-02	4.59E-04	2.11E-02
7	-9.78E-03	3.25E-02	2.35E-02	8.52E-03	-3.79E-03	-1.17E-02	-1.36E-02	-9.07E-03	3.51E-03	2.54E-02
8	9.38E-03	4.28E-02	2.83E-02	1.03E-02	-3.60E-03	-1.22E-02	-1.43E-02	-9.28E-03	3.55E-03	2.63E-02
9	8.14E-03	4.05E-02	2.45E-02	5.58E-03	-8.70E-03	-1.74E-02	-1.93E-02	-1.44E-02	-8.67E-04	2.24E-02
10	-1.99E-02	2.12E-02	9.02E-03	-7.87E-03	-2.09E-02	-2.88E-02	-3.01E-02	-2.43E-02	-1.08E-02	1.27E-02

Low	1	2	3	4	5	6	7	8	9	10
1	-1.25E-02	4.02E-02	4.13E-02	2.81E-02	1.22E-02	-1.59E-03	-1.12E-02	-1.51E-02	-1.26E-02	-2.20E-03
2	-5.57E-02	1.26E-02	2.19E-02	1.46E-02	3.77E-03	-5.92E-03	-1.14E-02	-1.15E-02	-5.07E-03	9.71E-03
3	-4.33E-02	1.60E-02	2.08E-02	1.23E-02	1.95E-03	-6.45E-03	-1.01E-02	-8.32E-03	8.99E-04	1.88E-02
4	-1.56E-02	2.76E-02	2.36E-02	1.11E-02	-7.23E-04	-9.29E-03	-1.24E-02	-9.21E-03	1.27E-03	2.11E-02
5	-6.04E-03	2.73E-02	1.73E-02	1.95E-03	-1.10E-02	-1.97E-02	-2.26E-02	-1.88E-02	-7.52E-03	1.33E-02

High	1	2	3	4	5	6	7	8	9	10
6	-2.73E-02	2.88E-03	8.14E-03	7.43E-03	5.88E-03	5.20E-03	7.56E-03	1.37E-02	2.54E-02	4.38E-02
7	-9.75E-03	9.67E-03	5.50E-03	-1.21E-03	-6.53E-03	-9.61E-03	-8.92E-03	-4.06E-03	6.58E-03	2.39E-02
8	-1.02E-03	1.81E-02	8.53E-03	-2.65E-03	-1.12E-02	-1.67E-02	-1.78E-02	-1.41E-02	-4.97E-03	1.12E-02
9	-1.01E-03	2.55E-02	1.42E-02	2.91E-04	-1.07E-02	-1.82E-02	-2.10E-02	-1.90E-02	-1.09E-02	4.07E-03
10	-8.77E-03	3.04E-02	2.06E-02	5.61E-03	-6.92E-03	-1.59E-02	-2.01E-02	-1.90E-02	-1.24E-02	1.43E-03

500 keV Poly-SS Dose (Fractional Difference)

Full	1	2	3	4	5	6	7	8	9	10
1	2.24E-01	1.71E-01	1.32E-01	1.02E-01	7.69E-02	5.66E-02	4.00E-02	2.67E-02	1.64E-02	8.72E-03
2	3.85E-02	3.68E-02	2.86E-02	1.95E-02	1.10E-02	3.75E-03	-1.91E-03	-5.88E-03	-8.00E-03	-8.20E-03
3	-3.63E-02	-2.09E-02	-1.76E-02	-1.77E-02	-1.88E-02	-1.96E-02	-1.95E-02	-1.82E-02	-1.54E-02	-1.09E-02
4	-5.76E-02	-3.67E-02	-2.99E-02	-2.72E-02	-2.56E-02	-2.38E-02	-2.12E-02	-1.73E-02	-1.20E-02	-4.90E-03
5	-5.33E-02	-3.08E-02	-2.38E-02	-2.10E-02	-1.93E-02	-1.72E-02	-1.40E-02	-9.50E-03	-3.34E-03	4.72E-03
6	-3.88E-02	-1.57E-02	-9.73E-03	-8.18E-03	-7.52E-03	-6.38E-03	-4.01E-03	-1.15E-04	5.59E-03	1.33E-02
7	-2.34E-02	2.24E-04	4.99E-03	4.91E-03	3.84E-03	3.31E-03	4.11E-03	6.51E-03	1.08E-02	1.72E-02
8	-1.28E-02	1.18E-02	1.55E-02	1.37E-02	1.07E-02	8.21E-03	6.98E-03	7.34E-03	9.52E-03	1.39E-02
9	-9.77E-03	1.60E-02	1.90E-02	1.58E-02	1.10E-02	5.90E-03	2.51E-03	6.63E-04	5.79E-04	2.41E-03
10	-1.54E-02	1.17E-02	1.36E-02	9.09E-03	2.61E-03	-3.89E-03	-9.50E-03	-1.38E-02	-1.70E-02	-1.79E-02

Low	1	2	3	4	5	6	7	8	9	10
1	7.62E-02	5.44E-02	3.96E-02	2.85E-02	1.98E-02	1.26E-02	6.72E-03	1.54E-03	-3.19E-03	-7.85E-03
2	-2.76E-02	-1.75E-02	-1.37E-02	-1.15E-02	-9.71E-03	-7.96E-03	-6.08E-03	-4.24E-03	-2.58E-03	-1.33E-03
3	-3.89E-02	-2.36E-02	-1.75E-02	-1.35E-02	-1.01E-02	-6.65E-03	-2.99E-03	6.56E-04	4.17E-03	7.30E-03
4	-1.78E-02	-4.29E-03	-1.67E-03	-1.06E-03	-5.09E-04	5.07E-04	2.07E-03	3.91E-03	5.86E-03	7.61E-03
5	5.71E-03	1.62E-02	1.39E-02	9.40E-03	5.08E-03	1.52E-03	-1.19E-03	-3.37E-03	-5.22E-03	-7.05E-03

High	1	2	3	4	5	6	7	8	9	10
6	6.98E-03	1.39E-02	8.11E-03	1.58E-03	-3.11E-03	-5.43E-03	-5.37E-03	-3.31E-03	4.31E-04	5.43E-03
7	-6.53E-03	7.15E-03	4.96E-03	4.31E-04	-3.27E-03	-5.26E-03	-5.31E-03	-3.70E-03	-6.56E-04	3.44E-03
8	-1.41E-02	5.27E-03	6.00E-03	2.91E-03	-2.66E-04	-2.32E-03	-2.88E-03	-2.12E-03	-2.39E-04	2.67E-03
9	-1.96E-02	4.72E-03	8.00E-03	6.17E-03	3.43E-03	5.98E-04	-6.27E-04	-7.96E-04	-6.38E-05	1.30E-03
10	-2.53E-02	3.51E-03	8.39E-03	7.55E-03	5.00E-03	2.39E-03	3.35E-04	-1.01E-03	-2.34E-03	-2.63E-03

1 MeV Poly-SS Dose (Fractional Difference)

Full	1	2	3	4	5	6	7	8	9	10
1	2.33E-01	1.70E-01	1.28E-01	9.63E-02	7.18E-02	5.21E-02	3.56E-02	2.16E-02	9.51E-03	-1.28E-03
2	4.29E-02	3.45E-02	2.56E-02	1.75E-02	1.06E-02	4.61E-03	-5.63E-04	-5.09E-03	-9.11E-03	-1.29E-02
3	-3.50E-02	-2.51E-02	-2.10E-02	-1.88E-02	-1.73E-02	-1.61E-02	-1.50E-02	-1.41E-02	-1.32E-02	-1.25E-02
4	-5.77E-02	-4.28E-02	-3.46E-02	-2.88E-02	-2.39E-02	-1.95E-02	-1.55E-02	-1.18E-02	-8.23E-03	-5.09E-03
5	-5.26E-02	-3.79E-02	-2.98E-02	-2.37E-02	-1.83E-02	-1.33E-02	-8.47E-03	-3.84E-03	6.11E-04	4.70E-03
6	-3.55E-02	-2.27E-02	-1.65E-02	-1.20E-02	-7.77E-03	-3.69E-03	7.80E-04	4.83E-03	8.78E-03	1.30E-02
7	-1.59E-02	-5.48E-03	-2.06E-03	3.09E-05	2.45E-03	4.66E-03	7.13E-03	1.02E-02	1.30E-02	1.56E-02
8	2.12E-04	8.18E-03	8.80E-03	8.22E-03	8.17E-03	8.10E-03	8.48E-03	9.65E-03	1.06E-02	1.16E-02
9	9.30E-03	1.51E-02	1.30E-02	9.81E-03	7.20E-03	4.69E-03	2.73E-03	1.69E-03	5.27E-04	-4.74E-04
10	9.94E-03	1.38E-02	9.51E-03	3.84E-03	-1.21E-03	-6.11E-03	-1.04E-02	-1.37E-02	-1.70E-02	-2.01E-02

Low	1	2	3	4	5	6	7	8	9	10
1	6.93E-02	5.10E-02	3.80E-02	2.78E-02	1.93E-02	1.22E-02	5.95E-03	3.63E-04	-4.79E-03	-9.88E-03
2	-3.10E-02	-1.98E-02	-1.40E-02	-1.04E-02	-7.84E-03	-5.80E-03	-4.17E-03	-2.91E-03	-2.03E-03	-1.73E-03
3	-3.81E-02	-2.54E-02	-1.83E-02	-1.30E-02	-8.58E-03	-4.59E-03	-9.98E-04	2.20E-03	4.99E-03	7.13E-03
4	-1.17E-02	-5.50E-03	-3.58E-03	-2.25E-03	-8.03E-04	9.01E-04	2.71E-03	4.52E-03	6.18E-03	7.41E-03
5	1.79E-02	1.61E-02	1.09E-02	6.24E-03	2.54E-03	-1.82E-04	-2.24E-03	-3.84E-03	-5.21E-03	-6.67E-03

High	1	2	3	4	5	6	7	8	9	10
6	6.93E-03	7.39E-03	4.10E-03	1.35E-03	-2.91E-04	-9.91E-04	-6.49E-04	-3.71E-04	-8.62E-05	3.15E-04
7	-3.57E-03	4.70E-04	-8.58E-04	-2.28E-03	-2.53E-03	-2.45E-03	-1.84E-03	-5.42E-04	2.41E-04	6.36E-04
8	-6.14E-03	-1.31E-04	-4.89E-04	-1.40E-03	-1.40E-03	-1.24E-03	-6.43E-04	5.68E-04	1.23E-03	1.48E-03
9	-5.48E-03	1.75E-03	1.74E-03	7.71E-04	4.93E-04	2.44E-04	3.38E-04	1.02E-03	1.11E-03	7.89E-04
10	-4.41E-03	3.59E-03	3.58E-03	2.23E-03	1.36E-03	3.92E-04	-3.05E-04	-4.80E-04	-1.24E-03	-2.41E-03

2 MeV Poly-SS Dose (Fractional Difference)

Full	1	2	3	4	5	6	7	8	9	10
1	2.02E-01	1.47E-01	1.11E-01	8.27E-02	6.03E-02	4.17E-02	2.58E-02	1.21E-02	2.12E-04	-1.03E-02
2	3.36E-02	2.87E-02	2.28E-02	1.67E-02	1.06E-02	4.59E-03	-1.06E-03	-6.32E-03	-1.12E-02	-1.56E-02
3	-3.77E-02	-2.53E-02	-1.83E-02	-1.44E-02	-1.23E-02	-1.13E-02	-1.10E-02	-1.12E-02	-1.16E-02	-1.21E-02
4	-5.92E-02	-4.23E-02	-3.12E-02	-2.34E-02	-1.76E-02	-1.34E-02	-1.01E-02	-7.55E-03	-5.44E-03	-3.65E-03
5	-5.40E-02	-3.84E-02	-2.77E-02	-1.96E-02	-1.33E-02	-8.18E-03	-3.93E-03	-3.06E-04	2.87E-03	5.71E-03
6	-3.60E-02	-2.43E-02	-1.62E-02	-9.95E-03	-4.78E-03	-3.95E-04	3.45E-03	6.89E-03	1.00E-02	1.30E-02
7	-1.43E-02	-7.60E-03	-3.33E-03	8.31E-05	3.05E-03	5.74E-03	8.26E-03	1.07E-02	1.30E-02	1.53E-02
8	4.86E-03	6.45E-03	6.55E-03	6.62E-03	6.84E-03	7.30E-03	7.98E-03	8.85E-03	9.89E-03	1.11E-02
9	1.77E-02	1.45E-02	1.06E-02	7.23E-03	4.61E-03	2.63E-03	1.21E-03	2.80E-04	-2.65E-04	-4.72E-04
10	2.24E-02	1.50E-02	7.41E-03	9.05E-04	-4.46E-03	-8.81E-03	-1.23E-02	-1.51E-02	-1.73E-02	-1.90E-02

Low	1	2	3	4	5	6	7	8	9	10
1	5.98E-02	4.37E-02	3.26E-02	2.36E-02	1.60E-02	9.24E-03	3.37E-03	-1.80E-03	-6.32E-03	-1.03E-02
2	-3.00E-02	-1.88E-02	-1.22E-02	-8.16E-03	-5.61E-03	-3.99E-03	-2.92E-03	-2.15E-03	-1.54E-03	-1.08E-03
3	-3.58E-02	-2.38E-02	-1.59E-02	-1.02E-02	-5.81E-03	-2.36E-03	5.24E-04	3.03E-03	5.30E-03	7.35E-03
4	-9.55E-03	-5.53E-03	-3.22E-03	-1.47E-03	1.75E-04	1.60E-03	3.00E-03	4.42E-03	5.84E-03	7.29E-03
5	2.07E-02	1.45E-02	8.91E-03	4.50E-03	1.12E-03	-1.44E-03	-3.31E-03	-4.65E-03	-5.54E-03	-6.08E-03

High	1	2	3	4	5	6	7	8	9	10
6	4.99E-03	4.44E-03	3.28E-03	2.40E-03	1.74E-03	1.18E-03	6.09E-04	-9.65E-05	-1.03E-03	-2.28E-03
7	-3.74E-03	-2.52E-03	-2.22E-03	-1.81E-03	-1.26E-03	-6.72E-04	-1.90E-04	1.11E-04	1.29E-04	-2.35E-04
8	-4.19E-03	-2.82E-03	-2.44E-03	-1.88E-03	-1.14E-03	-3.13E-04	4.66E-04	1.07E-03	1.41E-03	1.38E-03
9	-6.64E-04	-8.86E-05	-4.44E-04	-4.94E-04	-2.11E-04	2.46E-04	7.48E-04	1.17E-03	1.36E-03	1.23E-03
10	3.78E-03	3.06E-03	1.49E-03	3.93E-04	-2.35E-04	-5.36E-04	-6.79E-04	-8.30E-04	-1.11E-03	-1.63E-03

6 MeV Poly-SS Dose (Fractional Difference)

Full	1	2	3	4	5	6	7	8	9	10
1	1.31E-01	1.19E-01	1.04E-01	8.68E-02	6.81E-02	4.96E-02	3.21E-02	1.62E-02	2.31E-03	-9.49E-03
2	9.68E-03	2.43E-02	2.87E-02	2.61E-02	1.95E-02	1.09E-02	1.87E-03	-6.52E-03	-1.41E-02	-2.00E-02
3	-4.38E-02	-2.00E-02	-7.74E-03	-3.42E-03	-3.64E-03	-6.58E-03	-1.03E-02	-1.43E-02	-1.76E-02	-1.94E-02
4	-6.07E-02	-3.53E-02	-2.05E-02	-1.34E-02	-1.06E-02	-1.05E-02	-1.16E-02	-1.24E-02	-1.29E-02	-1.19E-02
5	-5.62E-02	-3.31E-02	-1.90E-02	-1.16E-02	-7.93E-03	-6.64E-03	-5.94E-03	-5.36E-03	-4.01E-03	-1.16E-03
6	-3.94E-02	-2.12E-02	-9.96E-03	-3.94E-03	-8.56E-04	4.60E-04	1.60E-03	2.94E-03	5.30E-03	9.38E-03
7	-1.76E-02	-6.11E-03	9.99E-04	4.43E-03	5.97E-03	6.47E-03	7.33E-03	8.77E-03	1.15E-02	1.63E-02
8	3.01E-03	6.84E-03	8.98E-03	9.16E-03	8.58E-03	7.76E-03	7.85E-03	8.94E-03	1.17E-02	1.67E-02
9	1.70E-02	1.30E-02	9.95E-03	6.66E-03	3.74E-03	1.35E-03	2.01E-04	8.98E-04	3.30E-03	8.14E-03
10	2.05E-02	9.16E-03	1.26E-03	-5.32E-03	-1.05E-02	-1.44E-02	-1.67E-02	-1.68E-02	-1.49E-02	-1.04E-02

Low	1	2	3	4	5	6	7	8	9	10
1	3.74E-02	3.36E-02	3.05E-02	2.54E-02	1.89E-02	1.18E-02	4.65E-03	-2.03E-03	-7.95E-03	-1.29E-02
2	-3.04E-02	-1.76E-02	-8.64E-03	-3.86E-03	-1.96E-03	-1.79E-03	-2.51E-03	-3.24E-03	-3.95E-03	-3.88E-03
3	-3.24E-02	-2.13E-02	-1.25E-02	-6.70E-03	-2.94E-03	-7.53E-04	9.97E-04	2.40E-03	4.07E-03	6.55E-03
4	-6.90E-03	-5.51E-03	-2.66E-03	-5.97E-04	9.17E-04	1.84E-03	2.78E-03	4.29E-03	6.18E-03	9.12E-03
5	2.32E-02	1.18E-02	5.80E-03	1.65E-03	-1.30E-03	-3.64E-03	-4.87E-03	-5.37E-03	-4.81E-03	-2.87E-03

High	1	2	3	4	5	6	7	8	9	10
6	5.65E-04	1.50E-03	3.61E-03	4.54E-03	4.44E-03	3.22E-03	1.69E-03	-2.94E-04	-2.24E-03	-3.74E-03
7	-4.95E-03	-4.27E-03	-1.82E-03	-1.45E-04	7.40E-04	6.40E-04	3.14E-04	-4.26E-04	-1.12E-03	-1.34E-03
8	-3.32E-03	-4.20E-03	-2.48E-03	-9.95E-04	6.65E-05	3.86E-04	6.33E-04	5.87E-04	6.66E-04	1.27E-03
9	1.96E-03	-1.40E-03	-1.19E-03	-5.72E-04	5.94E-05	2.59E-04	3.85E-04	8.29E-04	1.29E-03	2.36E-03
10	8.11E-03	1.65E-03	-2.05E-04	-9.38E-04	-1.18E-03	-1.50E-03	-1.64E-03	-1.27E-03	-7.30E-04	5.30E-04

10 MeV Poly-SS Dose (Fractional Difference)

Full	1	2	3	4	5	6	7	8	9	10
1	9.74E-02	9.67E-02	9.32E-02	8.48E-02	7.30E-02	5.95E-02	4.54E-02	3.15E-02	1.87E-02	7.26E-03
2	-5.36E-04	1.43E-02	2.18E-02	2.26E-02	1.90E-02	1.26E-02	5.07E-03	-2.91E-03	-1.01E-02	-1.62E-02
3	-4.20E-02	-2.25E-02	-1.09E-02	-6.00E-03	-5.76E-03	-8.25E-03	-1.21E-02	-1.64E-02	-1.99E-02	-2.24E-02
4	-5.34E-02	-3.36E-02	-2.10E-02	-1.47E-02	-1.27E-02	-1.31E-02	-1.48E-02	-1.67E-02	-1.78E-02	-1.76E-02
5	-4.73E-02	-2.95E-02	-1.77E-02	-1.15E-02	-9.05E-03	-8.71E-03	-9.17E-03	-9.68E-03	-9.03E-03	-6.82E-03
6	-3.14E-02	-1.72E-02	-7.59E-03	-2.58E-03	-6.72E-04	-3.31E-04	-3.48E-04	-3.82E-05	1.77E-03	5.48E-03
7	-1.21E-02	-2.76E-03	3.69E-03	6.71E-03	7.44E-03	7.20E-03	7.10E-03	7.73E-03	1.02E-02	1.50E-02
8	4.68E-03	8.43E-03	1.12E-02	1.17E-02	1.08E-02	9.60E-03	9.01E-03	9.58E-03	1.24E-02	1.77E-02
9	1.39E-02	1.17E-02	1.05E-02	8.36E-03	5.64E-03	3.24E-03	1.92E-03	2.11E-03	4.80E-03	1.03E-02
10	1.16E-02	3.73E-03	-1.29E-03	-6.06E-03	-1.06E-02	-1.43E-02	-1.64E-02	-1.68E-02	-1.45E-02	-9.29E-03

Low	1	2	3	4	5	6	7	8	9	10
1	2.37E-02	2.51E-02	2.67E-02	2.50E-02	2.05E-02	1.44E-02	7.58E-03	6.62E-04	-5.71E-03	-1.11E-02
2	-2.81E-02	-1.65E-02	-7.54E-03	-2.72E-03	-1.13E-03	-1.58E-03	-3.04E-03	-4.94E-03	-6.23E-03	-6.61E-03
3	-2.75E-02	-1.81E-02	-9.86E-03	-4.62E-03	-1.87E-03	-6.08E-04	1.92E-05	5.11E-04	1.89E-03	4.44E-03
4	-5.37E-03	-4.15E-03	-9.96E-04	1.11E-03	2.04E-03	2.43E-03	2.88E-03	3.75E-03	5.94E-03	9.68E-03
5	1.90E-02	8.96E-03	4.48E-03	1.25E-03	-1.57E-03	-3.84E-03	-5.23E-03	-5.59E-03	-4.15E-03	-7.83E-04

High	1	2	3	4	5	6	7	8	9	10
6	-6.23E-04	-3.74E-04	2.50E-03	4.36E-03	4.69E-03	3.84E-03	2.27E-03	1.83E-04	-1.62E-03	-3.03E-03
7	-4.25E-03	-4.78E-03	-2.07E-03	4.80E-05	9.30E-04	8.48E-04	2.16E-04	-8.08E-04	-1.43E-03	-1.57E-03
8	-2.08E-03	-4.22E-03	-2.37E-03	-6.02E-04	2.91E-04	4.95E-04	3.47E-04	-1.53E-05	1.65E-04	9.58E-04
9	2.88E-03	-1.54E-03	-1.09E-03	-1.51E-04	3.23E-04	4.11E-04	3.92E-04	3.47E-04	1.00E-03	2.41E-03
10	8.14E-03	9.51E-04	-4.36E-04	-7.08E-04	-1.01E-03	-1.36E-03	-1.56E-03	-1.59E-03	-7.46E-04	9.96E-04

Stainless Steel Followed by Polyethylene (SS-Poly)

65 keV SS-Poly Dose (Fractional Difference)

Full	1	2	3	4	5	6	7	8	9	10
1	8.17E-02	4.50E-02	2.53E-02	1.42E-02	5.87E-03	-1.37E-03	-7.41E-03	-1.16E-02	-1.32E-02	-1.15E-02
2	2.76E-02	1.05E-02	2.73E-03	-4.69E-04	-3.09E-03	-6.01E-03	-8.69E-03	-1.01E-02	-9.33E-03	-5.49E-03
3	-5.60E-03	-9.12E-03	-8.60E-03	-6.28E-03	-5.03E-03	-5.08E-03	-5.53E-03	-5.14E-03	-2.80E-03	2.48E-03
4	-2.48E-02	-1.90E-02	-1.28E-02	-6.93E-03	-3.24E-03	-1.58E-03	-7.30E-04	6.92E-04	3.92E-03	1.01E-02
5	-3.35E-02	-2.18E-02	-1.24E-02	-4.55E-03	2.40E-04	2.58E-03	3.87E-03	5.62E-03	9.12E-03	1.56E-02
6	-3.35E-02	-1.92E-02	-8.72E-03	-6.69E-04	3.99E-03	6.02E-03	6.96E-03	8.34E-03	1.16E-02	1.78E-02
7	-2.63E-02	-1.26E-02	-3.24E-03	3.47E-03	6.78E-03	7.55E-03	7.37E-03	7.83E-03	1.03E-02	1.58E-02
8	-1.31E-02	-3.04E-03	2.95E-03	6.75E-03	7.55E-03	6.22E-03	4.25E-03	3.20E-03	4.34E-03	8.81E-03
9	5.05E-03	8.37E-03	8.91E-03	8.33E-03	5.56E-03	1.33E-03	-3.03E-03	-6.06E-03	-6.61E-03	-3.63E-03
10	2.71E-02	2.05E-02	1.36E-02	7.24E-03	-1.70E-05	-7.85E-03	-1.51E-02	-2.05E-02	-2.31E-02	-2.19E-02

Low	1	2	3	4	5	6	7	8	9	10
1	3.00E-02	1.30E-02	6.09E-03	3.61E-03	1.34E-03	-1.60E-03	-4.60E-03	-6.69E-03	-6.86E-03	-4.21E-03
2	-7.25E-03	-8.57E-03	-6.16E-03	-2.48E-03	-3.92E-04	-1.14E-04	-6.54E-04	-6.99E-04	8.79E-04	5.12E-03
3	-1.86E-02	-1.32E-02	-7.21E-03	-1.46E-03	1.82E-03	2.86E-03	2.83E-03	3.17E-03	5.10E-03	9.70E-03
4	-1.11E-02	-6.51E-03	-1.95E-03	2.13E-03	3.85E-03	3.46E-03	2.22E-03	1.51E-03	2.55E-03	6.45E-03
5	1.14E-02	8.11E-03	6.36E-03	5.35E-03	2.92E-03	-8.43E-04	-4.87E-03	-7.88E-03	-8.80E-03	-6.58E-03

High	1	2	3	4	5	6	7	8	9	10
6	-4.68E-01	-9.01E-02	-1.15E-04	1.37E-02	9.51E-03	5.12E-03	5.29E-03	8.44E-03	8.13E-03	-6.62E-03
7	-3.47E-01	-4.69E-02	1.24E-02	1.28E-02	2.76E-03	-3.54E-03	-2.82E-03	2.71E-03	6.20E-03	-4.06E-03
8	-2.16E-01	4.23E-03	3.13E-02	1.72E-02	2.38E-04	-8.87E-03	-8.45E-03	-1.35E-03	5.15E-03	-1.28E-03
9	-7.86E-02	6.19E-02	5.56E-02	2.58E-02	1.14E-03	-1.16E-02	-1.23E-02	-4.43E-03	4.26E-03	9.06E-04
10	6.51E-02	1.25E-01	8.39E-02	3.77E-02	4.53E-03	-1.26E-02	-1.51E-02	-7.36E-03	2.65E-03	1.50E-03

100 keV SS-Poly Dose (Log Fit Fractional Difference)

Full	1	2	3	4	5	6	7	8	9	10
1	1.57E-01	9.64E-02	5.72E-02	3.24E-02	1.49E-02	1.81E-03	-8.07E-03	-1.50E-02	-1.88E-02	-1.91E-02
2	4.25E-02	2.21E-02	6.25E-03	-3.16E-03	-9.33E-03	-1.38E-02	-1.69E-02	-1.81E-02	-1.70E-02	-1.31E-02
3	-1.99E-02	-1.59E-02	-1.69E-02	-1.63E-02	-1.53E-02	-1.43E-02	-1.30E-02	-1.06E-02	-6.52E-03	1.21E-04
4	-5.22E-02	-3.26E-02	-2.41E-02	-1.72E-02	-1.18E-02	-7.56E-03	-3.78E-03	5.64E-04	6.37E-03	1.46E-02
5	-6.39E-02	-3.50E-02	-2.11E-02	-1.10E-02	-3.64E-03	1.78E-03	6.40E-03	1.13E-02	1.76E-02	2.63E-02
6	-6.05E-02	-2.75E-02	-1.22E-02	-1.87E-03	5.21E-03	1.00E-02	1.40E-02	1.82E-02	2.39E-02	3.21E-02
7	-4.54E-02	-1.36E-02	-6.00E-04	7.18E-03	1.17E-02	1.42E-02	1.61E-02	1.85E-02	2.26E-02	2.94E-02
8	-2.15E-02	4.01E-03	1.09E-02	1.33E-02	1.33E-02	1.19E-02	1.04E-02	1.00E-02	1.17E-02	1.63E-02
9	8.04E-03	2.23E-02	1.95E-02	1.41E-02	7.70E-03	1.13E-03	-4.60E-03	-8.62E-03	-1.00E-02	-8.14E-03
10	4.08E-02	3.86E-02	2.30E-02	7.71E-03	-6.36E-03	-1.91E-02	-2.98E-02	-3.79E-02	-4.28E-02	-4.40E-02

Low	1	2	3	4	5	6	7	8	9	10
1	5.89E-02	3.10E-02	1.48E-02	6.27E-03	8.30E-04	-3.58E-03	-7.24E-03	-9.97E-03	-1.12E-02	-1.04E-02
2	-1.87E-02	-1.42E-02	-1.21E-02	-8.39E-03	-5.02E-03	-2.74E-03	-1.14E-03	4.80E-04	2.90E-03	6.90E-03
3	-3.86E-02	-2.14E-02	-1.28E-02	-5.38E-03	3.08E-04	4.12E-03	6.78E-03	9.19E-03	1.23E-02	1.68E-02
4	-2.24E-02	-6.54E-03	-1.23E-03	2.72E-03	5.17E-03	6.10E-03	6.23E-03	6.47E-03	7.65E-03	1.06E-02
5	1.91E-02	2.08E-02	1.39E-02	7.87E-03	2.17E-03	-3.58E-03	-8.94E-03	-1.33E-02	-1.60E-02	-1.64E-02

High	1	2	3	4	5	6	7	8	9	10
6	-4.65E-02	-4.75E-02	-3.65E-02	-1.95E-02	-1.91E-03	1.41E-02	2.82E-02	4.06E-02	5.19E-02	6.27E-02
7	-6.10E-02	-5.51E-02	-4.00E-02	-2.05E-02	-1.25E-03	1.58E-02	3.05E-02	4.32E-02	5.47E-02	6.57E-02
8	-6.66E-02	-5.66E-02	-3.94E-02	-1.88E-02	7.75E-04	1.78E-02	3.23E-02	4.47E-02	5.58E-02	6.64E-02
9	-6.54E-02	-5.38E-02	-3.63E-02	-1.61E-02	2.71E-03	1.89E-02	3.23E-02	4.37E-02	5.38E-02	6.34E-02
10	-5.85E-02	-4.80E-02	-3.20E-02	-1.37E-02	3.32E-03	1.76E-02	2.93E-02	3.91E-02	4.77E-02	5.59E-02

500 keV SS-Poly Dose (Fractional Difference)

Full	1	2	3	4	5	6	7	8	9	10
1	-9.11E-02	1.50E-01	2.25E-01	2.33E-01	2.12E-01	1.77E-01	1.35E-01	9.01E-02	4.25E-02	-6.59E-03
2	-2.10E-01	-6.20E-03	7.10E-02	9.54E-02	9.49E-02	8.11E-02	5.92E-02	3.16E-02	-7.30E-04	-3.70E-02
3	-2.36E-01	-7.53E-02	-8.46E-03	1.92E-02	2.80E-02	2.60E-02	1.65E-02	6.48E-04	-2.09E-02	-4.81E-02
4	-2.15E-01	-9.53E-02	-4.35E-02	-1.86E-02	-6.24E-03	-1.55E-03	-3.03E-03	-1.05E-02	-2.42E-02	-4.44E-02
5	-1.67E-01	-8.55E-02	-5.09E-02	-3.17E-02	-1.91E-02	-1.08E-02	-6.83E-03	-8.17E-03	-1.58E-02	-3.06E-02
6	-1.03E-01	-5.84E-02	-4.15E-02	-2.99E-02	-1.91E-02	-9.13E-03	-1.60E-03	1.58E-03	-1.40E-03	-1.20E-02
7	-3.28E-02	-2.28E-02	-2.39E-02	-2.10E-02	-1.34E-02	-3.37E-03	6.20E-03	1.25E-02	1.30E-02	5.72E-03
8	3.60E-02	1.36E-02	-5.24E-03	-1.17E-02	-8.59E-03	-4.43E-06	1.01E-02	1.81E-02	2.08E-02	1.57E-02
9	9.69E-02	4.45E-02	8.45E-03	-7.92E-03	-1.04E-02	-4.72E-03	4.25E-03	1.23E-02	1.57E-02	1.15E-02
10	1.44E-01	6.47E-02	1.24E-02	-1.41E-02	-2.31E-02	-2.18E-02	-1.56E-02	-9.32E-03	-6.73E-03	-1.12E-02

Low	1	2	3	4	5	6	7	8	9	10
1	-1.40E-01	5.10E-03	5.46E-02	6.76E-02	6.51E-02	5.53E-02	4.10E-02	2.28E-02	3.33E-04	-2.70E-02
2	-1.61E-01	-6.16E-02	-2.30E-02	-5.99E-03	2.44E-03	6.51E-03	7.13E-03	3.75E-03	-4.81E-03	-1.99E-02
3	-8.80E-02	-4.52E-02	-3.19E-02	-2.42E-02	-1.66E-02	-8.38E-03	-8.69E-04	4.05E-03	4.17E-03	-2.81E-03
4	2.17E-02	7.46E-03	-9.30E-03	-1.70E-02	-1.63E-02	-1.00E-02	-1.24E-03	6.87E-03	1.12E-02	8.73E-03
5	1.35E-01	6.79E-02	2.05E-02	-5.06E-03	-1.50E-02	-1.48E-02	-9.36E-03	-2.61E-03	1.68E-03	-1.34E-04

High	1	2	3	4	5	6	7	8	9	10
6	-9.57E-02	-1.57E-02	1.01E-02	1.86E-02	2.04E-02	1.90E-02	1.51E-02	8.34E-03	-1.51E-03	-1.48E-02
7	-6.67E-02	-1.45E-02	-8.79E-04	3.18E-03	5.02E-03	6.04E-03	5.84E-03	3.59E-03	-1.57E-03	-1.03E-02
8	-2.86E-02	-3.06E-03	-2.24E-03	-3.52E-03	-2.89E-03	-6.57E-04	1.81E-03	3.03E-03	1.69E-03	-3.23E-03
9	1.34E-02	1.33E-02	1.21E-03	-6.12E-03	-7.62E-03	-5.15E-03	-9.88E-04	2.79E-03	4.51E-03	2.64E-03
10	5.46E-02	3.01E-02	5.14E-03	-8.73E-03	-1.31E-02	-1.13E-02	-6.41E-03	-9.52E-04	2.95E-03	3.47E-03

1 MeV SS-Poly Dose (Fractional Difference)

Full	1	2	3	4	5	6	7	8	9	10
1	1.05E+00	5.42E-01	2.57E-01	8.37E-02	-2.29E-02	-8.30E-02	-1.00E-01	1.80E-03	-1.79E-01	-5.71E-02
2	5.86E-01	2.60E-01	7.02E-02	-4.48E-02	-1.13E-01	-1.46E-01	-1.47E-01	-1.12E-01	2.33E-02	6.52E-02
3	3.70E-01	1.32E-01	-4.57E-03	-8.21E-02	-1.20E-01	-1.26E-01	-1.02E-01	-4.58E-02	2.99E-02	-5.86E-02
4	2.64E-01	7.56E-02	-2.82E-02	-8.08E-02	-9.83E-02	-8.73E-02	-5.08E-02	5.56E-03	5.66E-02	1.68E-02
5	2.12E-01	5.30E-02	-2.98E-02	-6.63E-02	-7.12E-02	-5.17E-02	-1.30E-02	3.45E-02	6.56E-02	2.86E-02
6	1.85E-01	4.57E-02	-2.37E-02	-5.02E-02	-4.83E-02	-2.62E-02	8.99E-03	4.55E-02	6.14E-02	2.37E-02
7	1.72E-01	4.41E-02	-1.69E-02	-3.76E-02	-3.30E-02	-1.18E-02	1.75E-02	4.34E-02	4.82E-02	9.67E-03
8	1.63E-01	4.34E-02	-1.25E-02	-3.04E-02	-2.55E-02	-7.35E-03	1.55E-02	3.24E-02	2.90E-02	-9.64E-03
9	1.56E-01	4.13E-02	-1.18E-02	-2.88E-02	-2.52E-02	-1.08E-02	5.83E-03	1.52E-02	6.04E-03	-3.23E-02
10	1.49E-01	3.67E-02	-1.51E-02	-3.24E-02	-3.09E-02	-2.05E-02	-9.45E-03	-6.08E-03	-1.93E-02	-5.68E-02

Low	1	2	3	4	5	6	7	8	9	10
1	1.13E-02	4.52E-02	5.15E-02	4.76E-02	3.92E-02	2.87E-02	1.72E-02	5.09E-03	-7.52E-03	-2.06E-02
2	-6.66E-02	-3.20E-02	-1.50E-02	-5.40E-03	-1.96E-04	1.87E-03	1.61E-03	-6.09E-04	-4.59E-03	-1.01E-02
3	-4.67E-02	-3.57E-02	-2.64E-02	-1.73E-02	-9.23E-03	-2.94E-03	1.46E-03	3.95E-03	4.45E-03	3.03E-03
4	1.07E-02	-8.22E-03	-1.38E-02	-1.18E-02	-6.80E-03	-1.42E-03	3.25E-03	6.66E-03	8.41E-03	8.40E-03
5	7.25E-02	2.40E-02	1.66E-03	-6.18E-03	-7.38E-03	-5.94E-03	-3.83E-03	-2.14E-03	-1.53E-03	-2.29E-03

High	1	2	3	4	5	6	7	8	9	10
6	-1.92E-02	1.44E-03	1.02E-02	1.42E-02	1.44E-02	1.15E-02	6.62E-03	6.03E-04	-5.72E-03	-1.16E-02
7	-2.05E-02	-8.19E-03	-1.85E-03	2.73E-03	4.97E-03	4.90E-03	2.95E-03	2.90E-05	-3.24E-03	-6.11E-03
8	-9.57E-03	-7.58E-03	-5.55E-03	-2.13E-03	6.55E-04	2.01E-03	2.05E-03	1.32E-03	3.54E-04	-1.45E-04
9	8.14E-03	-1.58E-03	-5.18E-03	-4.13E-03	-1.91E-03	-8.44E-05	1.07E-03	1.80E-03	2.53E-03	3.88E-03
10	2.74E-02	5.23E-03	-4.78E-03	-6.91E-03	-6.00E-03	-4.33E-03	-2.75E-03	-1.09E-03	8.40E-04	3.60E-03

2 MeV SS-Poly Dose (Fractional Difference)

Full	1	2	3	4	5	6	7	8	9	10
1	1.94E-01	1.41E-01	1.07E-01	8.22E-02	6.15E-02	4.37E-02	2.80E-02	1.38E-02	6.11E-04	-1.18E-02
2	2.69E-02	2.00E-02	1.78E-02	1.51E-02	1.14E-02	6.73E-03	1.39E-03	-4.47E-03	-1.08E-02	-1.75E-02
3	-3.90E-02	-3.32E-02	-2.36E-02	-1.61E-02	-1.14E-02	-9.00E-03	-8.43E-03	-9.33E-03	-1.14E-02	-1.46E-02
4	-5.41E-02	-4.83E-02	-3.59E-02	-2.48E-02	-1.66E-02	-1.10E-02	-7.51E-03	-5.80E-03	-5.61E-03	-6.73E-03
5	-4.31E-02	-4.26E-02	-3.17E-02	-2.07E-02	-1.19E-02	-5.49E-03	-1.08E-03	1.57E-03	2.67E-03	2.39E-03
6	-2.07E-02	-2.75E-02	-2.03E-02	-1.13E-02	-3.59E-03	2.22E-03	6.27E-03	8.75E-03	9.80E-03	9.56E-03
7	3.39E-03	-1.10E-02	-8.18E-03	-1.98E-03	3.67E-03	8.00E-03	1.09E-02	1.26E-02	1.30E-02	1.23E-02
8	2.31E-02	1.62E-03	8.33E-05	3.19E-03	6.49E-03	8.97E-03	1.04E-02	1.09E-02	1.03E-02	8.84E-03
9	3.49E-02	7.32E-03	1.82E-03	1.98E-03	2.95E-03	3.54E-03	3.44E-03	2.59E-03	9.94E-04	-1.36E-03
10	3.71E-02	4.72E-03	-4.11E-03	-6.52E-03	-7.65E-03	-8.80E-03	-1.04E-02	-1.24E-02	-1.50E-02	-1.82E-02

Low	1	2	3	4	5	6	7	8	9	10
1	5.02E-02	4.10E-02	3.33E-02	2.56E-02	1.80E-02	1.07E-02	4.05E-03	-1.95E-03	-7.30E-03	-1.20E-02
2	-3.35E-02	-2.21E-02	-1.26E-02	-6.70E-03	-3.53E-03	-2.07E-03	-1.59E-03	-1.63E-03	-1.92E-03	-2.32E-03
3	-3.18E-02	-2.65E-02	-1.73E-02	-9.82E-03	-4.53E-03	-8.82E-04	1.70E-03	3.62E-03	5.12E-03	6.40E-03
4	5.25E-04	-8.40E-03	-6.35E-03	-2.88E-03	-4.26E-05	2.04E-03	3.60E-03	4.86E-03	5.95E-03	6.98E-03
5	3.39E-02	1.00E-02	3.15E-03	6.47E-04	-8.92E-04	-2.14E-03	-3.19E-03	-4.02E-03	-4.62E-03	-5.00E-03

High	1	2	3	4	5	6	7	8	9	10
6	-5.33E-04	-1.25E-03	4.13E-03	7.28E-03	7.32E-03	5.30E-03	2.26E-03	-9.92E-04	-3.90E-03	-6.07E-03
7	-4.77E-03	-8.29E-03	-2.99E-03	1.24E-03	2.84E-03	2.51E-03	1.19E-03	-3.76E-04	-1.66E-03	-2.28E-03
8	-3.35E-04	-8.36E-03	-4.67E-03	-6.95E-04	1.31E-03	1.75E-03	1.37E-03	8.21E-04	6.06E-04	1.07E-03
9	8.02E-03	-5.36E-03	-4.16E-03	-1.26E-03	4.39E-04	1.01E-03	1.03E-03	1.04E-03	1.48E-03	2.65E-03
10	1.64E-02	-2.50E-03	-4.17E-03	-2.77E-03	-1.80E-03	-1.48E-03	-1.41E-03	-1.16E-03	-3.62E-04	1.26E-03

6 MeV SS-Poly Dose (Fractional Difference)

Full	1	2	3	4	5	6	7	8	9	10
1	7.08E-02	6.26E-02	4.80E-02	3.32E-02	2.04E-02	1.05E-02	3.90E-03	7.77E-04	1.14E-03	5.04E-03
2	-1.55E-02	4.86E-03	6.81E-03	2.78E-03	-2.41E-03	-6.58E-03	-8.73E-03	-8.27E-03	-4.93E-03	1.51E-03
3	-4.27E-02	-1.56E-02	-8.45E-03	-8.57E-03	-1.07E-02	-1.25E-02	-1.26E-02	-1.04E-02	-5.66E-03	2.05E-03
4	-4.05E-02	-1.50E-02	-8.06E-03	-8.01E-03	-9.83E-03	-1.12E-02	-1.09E-02	-8.37E-03	-3.23E-03	4.82E-03
5	-2.65E-02	-4.87E-03	-1.60E-04	-1.53E-03	-4.31E-03	-6.34E-03	-6.59E-03	-4.46E-03	3.29E-04	8.05E-03
6	-1.15E-02	6.70E-03	9.17E-03	6.16E-03	2.09E-03	-9.74E-04	-2.12E-03	-7.79E-04	3.28E-03	1.03E-02
7	-1.71E-03	1.46E-02	1.58E-02	1.17E-02	6.66E-03	2.68E-03	6.56E-04	1.14E-03	4.32E-03	1.05E-02
8	-1.50E-04	1.62E-02	1.74E-02	1.31E-02	7.67E-03	3.17E-03	5.23E-04	3.01E-04	2.72E-03	7.99E-03
9	-7.36E-03	1.05E-02	1.30E-02	9.44E-03	4.31E-03	-2.05E-04	-3.10E-03	-3.77E-03	-1.97E-03	2.53E-03
10	-2.26E-02	-1.95E-03	2.74E-03	6.65E-04	-3.53E-03	-7.55E-03	-1.03E-02	-1.11E-02	-9.73E-03	-5.82E-03

Low	1	2	3	4	5	6	7	8	9	10
1	3.94E-02	2.23E-02	1.19E-02	5.31E-03	9.97E-04	-1.67E-03	-3.06E-03	-3.32E-03	-2.61E-03	-9.65E-04
2	-1.78E-02	-9.21E-03	-6.78E-03	-5.88E-03	-5.25E-03	-4.39E-03	-3.14E-03	-1.34E-03	1.02E-03	4.03E-03
3	-2.24E-02	-8.20E-03	-3.67E-03	-2.13E-03	-1.46E-03	-7.89E-04	1.93E-04	1.70E-03	3.78E-03	6.52E-03
4	-1.13E-02	2.53E-03	5.37E-03	4.79E-03	3.36E-03	2.09E-03	1.33E-03	1.30E-03	2.00E-03	3.50E-03
5	-3.87E-03	8.93E-03	9.86E-03	6.93E-03	3.11E-03	-4.35E-04	-3.29E-03	-5.24E-03	-6.28E-03	-6.37E-03

High	1	2	3	4	5	6	7	8	9	10
6	-1.03E-02	6.61E-03	7.97E-03	4.07E-03	-6.35E-04	-4.11E-03	-5.44E-03	-4.09E-03	1.89E-04	7.63E-03
7	-9.40E-03	6.74E-03	7.91E-03	3.82E-03	-1.06E-03	-4.77E-03	-6.40E-03	-5.39E-03	-1.55E-03	5.42E-03
8	-8.77E-03	7.63E-03	9.10E-03	5.15E-03	1.78E-04	-3.75E-03	-5.71E-03	-5.12E-03	-1.75E-03	4.61E-03
9	-1.06E-02	7.09E-03	9.61E-03	6.27E-03	1.55E-03	-2.38E-03	-4.53E-03	-4.30E-03	-1.43E-03	4.34E-03
10	-1.59E-02	4.01E-03	8.28E-03	6.08E-03	2.03E-03	-1.61E-03	-3.74E-03	-3.71E-03	-1.22E-03	4.01E-03

10 MeV SS-Poly Dose (Fractional Difference)

Full	1	2	3	4	5	6	7	8	9	10
1	1.98E-02	5.04E-02	4.43E-02	2.95E-02	1.47E-02	3.23E-03	-3.87E-03	-6.04E-03	-3.18E-03	4.88E-03
2	-3.36E-02	1.42E-02	1.85E-02	1.06E-02	7.47E-04	-7.02E-03	-1.11E-02	-1.09E-02	-5.94E-03	3.94E-03
3	-4.79E-02	7.94E-04	7.58E-03	2.11E-03	-5.52E-03	-1.14E-02	-1.39E-02	-1.22E-02	-6.06E-03	4.94E-03
4	-4.14E-02	1.18E-03	6.38E-03	8.16E-04	-6.40E-03	-1.17E-02	-1.35E-02	-1.12E-02	-4.45E-03	7.13E-03
5	-2.66E-02	8.26E-03	1.04E-02	3.55E-03	-4.16E-03	-9.57E-03	-1.14E-02	-8.95E-03	-2.03E-03	9.70E-03
6	-1.20E-02	1.65E-02	1.58E-02	7.58E-03	-8.24E-04	-6.63E-03	-8.68E-03	-6.43E-03	3.59E-04	1.19E-02
7	-3.36E-03	2.17E-02	1.96E-02	1.07E-02	1.90E-03	-4.21E-03	-6.52E-03	-4.53E-03	1.98E-03	1.32E-02
8	-3.40E-03	2.16E-02	1.99E-02	1.13E-02	2.68E-03	-3.39E-03	-5.79E-03	-3.99E-03	2.22E-03	1.31E-02
9	-1.29E-02	1.49E-02	1.55E-02	8.44E-03	7.27E-04	-4.83E-03	-7.02E-03	-5.25E-03	7.61E-04	1.13E-02
10	-3.12E-02	1.56E-03	6.02E-03	1.58E-03	-4.44E-03	-8.96E-03	-1.06E-02	-8.61E-03	-2.67E-03	7.52E-03

Low	1	2	3	4	5	6	7	8	9	10
1	3.16E-02	1.66E-02	6.63E-03	5.25E-04	-3.01E-03	-4.61E-03	-4.64E-03	-3.20E-03	-4.71E-04	3.52E-03
2	-1.36E-02	-3.89E-03	-3.76E-03	-4.84E-03	-5.50E-03	-5.31E-03	-4.12E-03	-1.82E-03	1.55E-03	6.02E-03
3	-2.04E-02	-1.37E-03	1.35E-03	4.85E-04	-8.06E-04	-1.52E-03	-1.28E-03	8.34E-05	2.57E-03	6.21E-03
4	-1.68E-02	6.86E-03	9.83E-03	7.56E-03	4.32E-03	1.59E-03	-1.22E-04	-5.76E-04	2.24E-04	2.30E-03
5	-1.81E-02	9.88E-03	1.35E-02	1.02E-02	5.19E-03	4.78E-04	-3.24E-03	-5.65E-03	-6.73E-03	-6.42E-03

High	1	2	3	4	5	6	7	8	9	10
6	-2.20E-02	1.56E-02	1.85E-02	1.12E-02	2.38E-03	-4.56E-03	-8.26E-03	-8.04E-03	-3.66E-03	5.13E-03
7	-1.84E-02	1.32E-02	1.48E-02	7.81E-03	-1.55E-04	-6.13E-03	-8.86E-03	-7.73E-03	-2.48E-03	7.12E-03
8	-1.31E-02	1.26E-02	1.27E-02	5.69E-03	-1.71E-03	-6.95E-03	-8.92E-03	-7.05E-03	-1.10E-03	9.16E-03
9	-8.82E-03	1.20E-02	1.09E-02	3.97E-03	-2.93E-03	-7.52E-03	-8.83E-03	-6.32E-03	2.24E-04	1.10E-02
10	-7.71E-03	1.00E-02	8.33E-03	1.79E-03	-4.47E-03	-8.37E-03	-9.02E-03	-5.91E-03	1.17E-03	1.25E-02

Appendix 7: Exoposure Fit Fractional Differences

The following tables present the fractional differences between the Analytical fit and the Exposure Buildup Data at each thickness Point. The tables labeled “Low” are for 1-10 mfp of the first material followed by 1-5 mfp of the second material. “High” is for 1-10 mfp of the first material followed by 6-10 mfp of the second material. “Full” is for 1-10 mfp of the first material followed by 1-10 mfp of the second material.

The first material thicknesses increase along the rows, the second material thicknesses increase along columns. For example, for a full shield fit, column 2 shows fractional differences for shields with 2 mfp of material 1 followed by 1-10 mfp of material 2.

Aluminum followed by lead
65 keV Al-Pb Exposure (Fractional Difference)

Full	1	2	3	4	5	6	7	8	9	10
1	9.91E-02	9.53E-02	7.34E-02	5.13E-02	3.34E-02	2.06E-02	1.32E-02	1.13E-02	1.49E-02	2.38E-02
2	3.93E-03	2.99E-02	2.42E-02	1.21E-02	8.83E-04	-6.87E-03	-1.02E-02	-8.62E-03	-2.19E-03	1.03E-02
3	-4.06E-02	-1.82E-03	1.43E-04	-7.13E-03	-1.50E-02	-2.01E-02	-2.12E-02	-1.76E-02	-8.62E-03	5.71E-03
4	-5.44E-02	-1.08E-02	-6.09E-03	-1.18E-02	-1.85E-02	-2.28E-02	-2.30E-02	-1.83E-02	-8.19E-03	7.64E-03
5	-4.94E-02	-5.13E-03	-6.47E-04	-6.80E-03	-1.40E-02	-1.86E-02	-1.89E-02	-1.40E-02	-3.37E-03	1.33E-02
6	-3.45E-02	8.14E-03	1.07E-02	2.88E-03	-5.71E-03	-1.13E-02	-1.23E-02	-7.82E-03	2.40E-03	1.99E-02
7	-1.80E-02	2.16E-02	2.12E-02	1.08E-02	1.41E-04	-3.09E-03	-5.51E-03	-2.13E-03	7.73E-03	2.48E-02
8	-5.94E-03	3.11E-02	2.84E-02	1.61E-02	3.85E-03	-6.45E-04	-4.11E-03	-1.54E-03	7.71E-03	2.44E-02
9	-5.00E-03	3.04E-02	2.65E-02	1.32E-02	-5.34E-05	-5.43E-03	-9.73E-03	-7.92E-03	6.33E-04	1.67E-02
10	-1.93E-02	1.62E-02	1.27E-02	-5.44E-04	-1.38E-02	-1.95E-02	-2.42E-02	-2.30E-02	-1.52E-02	3.40E-05

Low	1	2	3	4	5	6	7	8	9	10
1	9.31E-03	2.45E-02	1.84E-02	8.58E-03	-2.59E-04	-6.52E-03	-9.55E-03	-9.06E-03	-4.82E-03	2.98E-03
2	-2.98E-02	5.38E-03	8.20E-03	2.92E-03	-3.14E-03	-7.33E-03	-8.55E-03	-6.22E-03	-3.96E-04	1.00E-02
3	-3.23E-02	7.19E-03	1.10E-02	5.70E-03	-5.54E-04	-4.77E-03	-5.72E-03	-2.80E-03	4.39E-03	1.58E-02
4	-1.88E-02	1.70E-02	1.72E-02	9.12E-03	8.62E-04	-4.68E-03	-6.38E-03	-3.72E-03	3.65E-03	1.57E-02
5	-7.19E-03	2.13E-02	1.63E-02	4.64E-03	-6.13E-03	-1.34E-02	-1.62E-02	-1.43E-02	-7.22E-03	4.82E-03

High	1	2	3	4	5	6	7	8	9	10
6	-2.13E-02	1.29E-02	1.13E-02	1.96E-03	-6.41E-03	-1.07E-02	-9.76E-03	-2.74E-03	1.05E-02	3.16E-02
7	-1.90E-02	1.51E-02	1.23E-02	1.28E-03	-9.10E-03	-1.15E-02	-1.27E-02	-7.94E-03	3.44E-03	2.21E-02
8	-1.52E-02	1.99E-02	1.68E-02	4.79E-03	-6.94E-03	-1.09E-02	-1.37E-02	-1.07E-02	-1.07E-03	1.58E-02
9	-1.35E-02	2.32E-02	2.04E-02	7.99E-03	-4.65E-03	-9.75E-03	-1.40E-02	-1.24E-02	-4.45E-03	1.07E-02
10	-1.58E-02	2.31E-02	2.14E-02	9.07E-03	-4.00E-03	-9.88E-03	-1.52E-02	-1.49E-02	-8.27E-03	5.29E-03

100 keV Al-Pb Exposure (Fractional Difference)

Full	1	2	3	4	5	6	7	8	9	10
1	2.27E-01	2.51E-01	2.61E-01	2.53E-01	2.26E-01	1.82E-01	1.28E-01	7.21E-02	2.17E-02	-1.44E-02
2	-8.88E-03	4.61E-02	7.40E-02	7.67E-02	5.85E-02	2.52E-02	-1.51E-02	-5.36E-02	-8.11E-02	-8.85E-02
3	-1.23E-01	-5.65E-02	-2.03E-02	-1.12E-02	-2.27E-02	-4.71E-02	-7.48E-02	-9.61E-02	-1.01E-01	-7.82E-02
4	-1.71E-01	-9.70E-02	-5.48E-02	-4.06E-02	-4.63E-02	-6.26E-02	-7.88E-02	-8.39E-02	-6.62E-02	-1.06E-02
5	-1.77E-01	-9.56E-02	-4.83E-02	-2.98E-02	-3.48E-02	-4.47E-02	-5.14E-02	-4.26E-02	-4.21E-03	8.32E-02
6	-1.55E-01	-6.74E-02	-1.75E-02	1.93E-03	-2.50E-03	-1.06E-02	-1.30E-02	3.63E-03	5.52E-02	1.64E-01
7	-1.14E-01	-2.30E-02	2.62E-02	4.20E-02	3.28E-02	2.05E-02	1.50E-02	3.02E-02	8.20E-02	1.94E-01
8	-6.35E-02	2.67E-02	7.00E-02	7.62E-02	5.59E-02	3.21E-02	1.50E-02	1.79E-02	5.49E-02	1.46E-01
9	-1.37E-02	7.07E-02	1.02E-01	9.25E-02	5.48E-02	1.33E-02	-2.24E-02	-4.04E-02	-2.98E-02	2.35E-02
10	2.66E-02	9.92E-02	1.13E-01	8.26E-02	2.38E-02	-3.89E-02	-9.61E-02	-1.38E-01	-1.57E-01	-1.45E-01

Low	1	2	3	4	5	6	7	8	9	10
1	1.01E-01	9.46E-02	8.70E-02	7.45E-02	5.70E-02	3.51E-02	1.16E-02	-9.97E-03	-2.58E-02	-3.31E-02
2	-6.51E-02	-3.44E-02	-1.91E-02	-1.60E-02	-2.06E-02	-2.90E-02	-3.56E-02	-3.48E-02	-2.11E-02	1.04E-02
3	-1.07E-01	-5.86E-02	-3.18E-02	-2.14E-02	-2.07E-02	-2.34E-02	-2.23E-02	-1.00E-02	2.00E-02	7.40E-02
4	-8.12E-02	-2.12E-02	1.03E-02	2.00E-02	1.63E-02	7.20E-03	1.07E-03	5.27E-03	2.59E-02	6.78E-02
5	-1.68E-02	4.84E-02	7.60E-02	7.43E-02	4.91E-02	1.87E-02	-1.24E-02	-3.75E-02	-5.22E-02	-5.45E-02

High	1	2	3	4	5	6	7	8	9	10
6	-2.15E-02	1.31E-02	1.08E-02	1.05E-03	-7.43E-03	-1.16E-02	-1.00E-02	-2.00E-03	1.23E-02	3.43E-02
7	-1.88E-02	1.59E-02	1.24E-02	6.94E-04	-1.00E-02	-1.25E-02	-1.33E-02	-7.91E-03	4.16E-03	2.34E-02
8	-1.50E-02	2.10E-02	1.73E-02	4.52E-03	-7.67E-03	-1.17E-02	-1.44E-02	-1.09E-02	-8.86E-04	1.61E-02
9	-1.37E-02	2.44E-02	2.12E-02	8.00E-03	-5.17E-03	-1.05E-02	-1.47E-02	-1.29E-02	-4.67E-03	1.04E-02
10	-1.65E-02	2.44E-02	2.24E-02	9.44E-03	-4.18E-03	-1.04E-02	-1.57E-02	-1.52E-02	-8.63E-03	4.60E-03

500 keV Al-Pb Exposure (Fractional Difference)

Full	1	2	3	4	5	6	7	8	9	10
1	4.62E-02	7.41E-02	6.69E-02	5.04E-02	3.26E-02	1.69E-02	4.58E-03	-3.77E-03	-7.65E-03	-6.69E-03
2	-3.09E-02	1.94E-02	2.70E-02	2.10E-02	1.10E-02	1.50E-03	-5.84E-03	-9.91E-03	-1.00E-02	-5.62E-03
3	-5.61E-02	-4.14E-03	7.12E-03	5.27E-03	-5.95E-04	-6.74E-03	-1.07E-02	-1.20E-02	-9.30E-03	-2.28E-03
4	-5.19E-02	-8.28E-03	7.43E-04	-8.08E-04	-5.34E-03	-9.73E-03	-1.18E-02	-1.11E-02	-6.51E-03	2.48E-03
5	-3.27E-02	-1.35E-03	2.50E-03	-8.56E-04	-5.61E-03	-9.43E-03	-1.07E-02	-8.63E-03	-2.70E-03	7.72E-03
6	-9.48E-03	9.77E-03	7.84E-03	1.93E-03	-3.75E-03	-7.63E-03	-8.26E-03	-5.69E-03	1.12E-03	1.25E-02
7	8.50E-03	1.93E-02	1.28E-02	4.71E-03	-1.91E-03	-6.02E-03	-6.64E-03	-3.47E-03	3.93E-03	1.61E-02
8	1.46E-02	2.29E-02	1.44E-02	5.20E-03	-1.87E-03	-5.84E-03	-6.42E-03	-2.90E-03	4.93E-03	1.76E-02
9	5.32E-03	1.77E-02	1.04E-02	1.71E-03	-4.94E-03	-8.51E-03	-8.51E-03	-4.75E-03	3.49E-03	1.65E-02
10	-1.99E-02	2.63E-03	-4.37E-04	-6.87E-03	-1.21E-02	-1.49E-02	-1.41E-02	-9.62E-03	-9.28E-04	1.24E-02

Low	1	2	3	4	5	6	7	8	9	10
1	-1.36E-02	2.78E-02	2.88E-02	1.88E-02	6.98E-03	-2.95E-03	-9.35E-03	-1.14E-02	-8.27E-03	5.57E-04
2	-3.65E-02	7.85E-03	1.34E-02	7.77E-03	-2.57E-04	-6.74E-03	-1.01E-02	-9.25E-03	-3.44E-03	8.05E-03
3	-2.13E-02	1.15E-02	1.30E-02	6.50E-03	-9.58E-04	-6.66E-03	-8.62E-03	-6.59E-03	6.38E-04	1.36E-02
4	-4.96E-03	1.83E-02	1.52E-02	6.73E-03	-1.41E-03	-7.13E-03	-8.77E-03	-6.28E-03	1.50E-03	1.51E-02
5	-9.11E-03	1.46E-02	1.09E-02	2.07E-03	-6.13E-03	-1.18E-02	-1.34E-02	-1.06E-02	-2.76E-03	1.08E-02

High	1	2	3	4	5	6	7	8	9	10
6	-1.59E-02	2.37E-03	7.20E-03	7.14E-03	5.33E-03	3.42E-03	3.11E-03	4.54E-03	8.84E-03	1.64E-02
7	-4.99E-03	4.16E-03	3.49E-03	6.06E-04	-2.52E-03	-4.92E-03	-5.42E-03	-3.62E-03	9.89E-04	8.86E-03
8	9.97E-04	7.97E-03	4.10E-03	-9.72E-04	-5.39E-03	-8.31E-03	-9.33E-03	-7.66E-03	-3.06E-03	4.84E-03
9	6.16E-04	1.12E-02	6.58E-03	3.61E-04	-4.98E-03	-8.55E-03	-9.82E-03	-8.59E-03	-4.17E-03	3.61E-03
10	-6.40E-03	1.23E-02	9.20E-03	2.96E-03	-2.75E-03	-6.87E-03	-8.47E-03	-7.34E-03	-3.14E-03	4.43E-03

1 MeV Al-Pb Exposure (Fractional Difference)

Full	1	2	3	4	5	6	7	8	9	10
1	7.82E-02	8.50E-02	7.03E-02	5.06E-02	3.16E-02	1.58E-02	4.19E-03	-2.70E-03	-4.32E-03	-2.87E-04
2	-2.04E-02	1.87E-02	2.29E-02	1.57E-02	5.76E-03	-3.20E-03	-9.29E-03	-1.15E-02	-9.00E-03	-1.13E-03
3	-5.70E-02	-8.91E-03	1.67E-03	-4.45E-04	-6.24E-03	-1.17E-02	-1.46E-02	-1.40E-02	-8.67E-03	1.93E-03
4	-5.97E-02	-1.30E-02	-2.65E-03	-4.11E-03	-8.81E-03	-1.29E-02	-1.44E-02	-1.22E-02	-5.25E-03	7.16E-03
5	-4.50E-02	-4.06E-03	2.81E-03	-4.08E-04	-5.85E-03	-1.00E-02	-1.13E-02	-8.39E-03	-5.97E-04	1.29E-02
6	-2.47E-02	9.75E-03	1.21E-02	6.16E-03	-8.68E-04	-5.90E-03	-7.49E-03	-4.59E-03	3.45E-03	1.74E-02
7	-7.53E-03	2.20E-02	2.04E-02	1.19E-02	3.20E-03	-2.86E-03	-5.08E-03	-2.52E-03	5.39E-03	1.93E-02
8	3.13E-04	2.78E-02	2.41E-02	1.39E-02	4.05E-03	-2.86E-03	-5.67E-03	-3.56E-03	3.99E-03	1.76E-02
9	-4.38E-03	2.45E-02	2.09E-02	1.03E-02	9.83E-05	-7.17E-03	-1.03E-02	-8.63E-03	-1.52E-03	1.16E-02
10	-2.22E-02	1.11E-02	9.61E-03	2.16E-04	-9.45E-03	-1.65E-02	-1.97E-02	-1.82E-02	-1.15E-02	9.34E-04

Low	1	2	3	4	5	6	7	8	9	10
1	2.11E-02	2.89E-02	2.25E-02	1.24E-02	2.66E-03	-4.86E-03	-9.03E-03	-9.26E-03	-4.80E-03	4.89E-03
2	-3.28E-02	-1.85E-03	3.28E-03	1.78E-04	-4.89E-03	-8.93E-03	-1.04E-02	-8.23E-03	-1.63E-03	1.01E-02
3	-3.27E-02	2.71E-03	8.55E-03	5.24E-03	-2.01E-04	-4.63E-03	-6.40E-03	-4.54E-03	1.84E-03	1.34E-02
4	-2.21E-02	1.43E-02	1.84E-02	1.30E-02	5.46E-03	-9.11E-04	-4.45E-03	-4.28E-03	4.68E-04	1.04E-02
5	-2.28E-02	1.66E-02	2.04E-02	1.37E-02	4.40E-03	-3.87E-03	-9.47E-03	-1.13E-02	-8.81E-03	-1.37E-03

High	1	2	3	4	5	6	7	8	9	10
6	-2.58E-02	1.44E-02	1.93E-02	1.38E-02	5.80E-03	-1.32E-03	-5.98E-03	-7.07E-03	-4.03E-03	3.71E-03
7	-2.58E-02	1.13E-02	1.50E-02	9.56E-03	2.32E-03	-3.63E-03	-6.87E-03	-6.39E-03	-1.62E-03	7.98E-03
8	-1.90E-02	1.25E-02	1.35E-02	7.03E-03	-2.06E-04	-5.57E-03	-7.86E-03	-6.18E-03	-2.93E-05	1.11E-02
9	-9.53E-03	1.50E-02	1.24E-02	4.41E-03	-3.24E-03	-8.34E-03	-9.90E-03	-7.37E-03	-8.82E-05	1.24E-02
10	-1.60E-03	1.59E-02	9.67E-03	3.88E-05	-8.11E-03	-1.31E-02	-1.42E-02	-1.08E-02	-2.62E-03	1.10E-02

2 MeV Al-Pb Exposure (Fractional Difference)

Full	1	2	3	4	5	6	7	8	9	10
1	1.46E-01	1.12E-01	8.48E-02	6.18E-02	4.27E-02	2.72E-02	1.52E-02	6.70E-03	1.75E-03	3.20E-04
2	1.48E-02	2.12E-02	1.71E-02	1.02E-02	2.83E-03	-3.44E-03	-7.93E-03	-1.01E-02	-9.61E-03	-6.08E-03
3	-4.01E-02	-1.85E-02	-1.25E-02	-1.23E-02	-1.39E-02	-1.55E-02	-1.60E-02	-1.46E-02	-1.07E-02	-4.08E-03
4	-5.49E-02	-2.80E-02	-1.89E-02	-1.62E-02	-1.58E-02	-1.56E-02	-1.44E-02	-1.13E-02	-5.79E-03	2.61E-03
5	-4.86E-02	-2.10E-02	-1.21E-02	-9.77E-03	-9.59E-03	-9.37E-03	-7.94E-03	-4.57E-03	1.43E-03	1.04E-02
6	-3.34E-02	-7.04E-03	-2.42E-05	6.29E-04	-5.77E-04	-1.43E-03	-8.09E-04	1.97E-03	7.56E-03	1.63E-02
7	-1.77E-02	6.96E-03	1.16E-02	1.00E-02	6.95E-03	4.49E-03	3.74E-03	5.36E-03	9.94E-03	1.78E-02
8	-6.70E-03	1.63E-02	1.87E-02	1.50E-02	9.94E-03	5.73E-03	3.41E-03	3.58E-03	6.80E-03	1.33E-02
9	-3.60E-03	1.83E-02	1.90E-02	1.35E-02	6.69E-03	8.57E-04	-3.01E-03	-4.35E-03	-2.67E-03	2.29E-03
10	-9.42E-03	1.19E-02	1.15E-02	4.71E-03	-3.38E-03	-1.06E-02	-1.58E-02	-1.87E-02	-1.83E-02	-1.51E-02

Low	1	2	3	4	5	6	7	8	9	10
1	5.09E-02	3.56E-02	2.39E-02	1.47E-02	7.28E-03	1.59E-03	-2.39E-03	-4.66E-03	-5.04E-03	-3.52E-03
2	-2.43E-02	-1.17E-02	-7.86E-03	-6.90E-03	-6.91E-03	-6.84E-03	-6.12E-03	-4.38E-03	-1.20E-03	3.58E-03
3	-3.24E-02	-1.29E-02	-6.19E-03	-3.84E-03	-3.06E-03	-2.43E-03	-1.25E-03	9.36E-04	4.56E-03	9.81E-03
4	-1.76E-02	1.60E-03	6.01E-03	5.74E-03	4.03E-03	2.41E-03	1.59E-03	1.97E-03	3.97E-03	7.72E-03
5	-4.02E-03	1.30E-02	1.37E-02	9.57E-03	4.23E-03	-7.43E-04	-4.65E-03	-7.14E-03	-7.86E-03	-6.73E-03

High	1	2	3	4	5	6	7	8	9	10
6	-3.93E-03	1.09E-02	9.52E-03	4.31E-03	-9.63E-04	-4.68E-03	-6.17E-03	-5.06E-03	-9.85E-04	6.22E-03
7	-1.28E-02	6.17E-03	7.07E-03	3.18E-03	-1.33E-03	-4.66E-03	-6.01E-03	-4.95E-03	-1.06E-03	5.85E-03
8	-1.60E-02	5.85E-03	8.19E-03	4.97E-03	6.33E-04	-2.82E-03	-4.49E-03	-3.91E-03	-6.35E-04	5.52E-03
9	-1.73E-02	6.87E-03	1.02E-02	7.27E-03	2.82E-03	-1.02E-03	-3.28E-03	-3.45E-03	-1.07E-03	4.05E-03
10	-1.89E-02	7.16E-03	1.13E-02	8.46E-03	3.75E-03	-6.02E-04	-3.58E-03	-4.79E-03	-3.16E-03	6.10E-04

6 MeV Al-Pb Exposure (Fractional Difference)

Full	1	2	3	4	5	6	7	8	9	10
1	1.30E-01	1.36E-01	1.35E-01	1.29E-01	1.18E-01	1.04E-01	8.70E-02	6.87E-02	4.95E-02	2.98E-02
2	7.88E-03	2.67E-02	3.62E-02	3.85E-02	3.57E-02	2.90E-02	1.96E-02	8.33E-03	-4.11E-03	-1.71E-02
3	-4.77E-02	-2.51E-02	-1.20E-02	-5.74E-03	-4.50E-03	-6.89E-03	-1.18E-02	-1.84E-02	-2.60E-02	-3.40E-02
4	-6.65E-02	-4.37E-02	-2.98E-02	-2.21E-02	-1.87E-02	-1.86E-02	-2.05E-02	-2.37E-02	-2.76E-02	-3.14E-02
5	-6.31E-02	-4.21E-02	-2.90E-02	-2.12E-02	-1.71E-02	-1.55E-02	-1.54E-02	-1.61E-02	-1.68E-02	-1.70E-02
6	-4.65E-02	-2.88E-02	-1.78E-02	-1.11E-02	-7.26E-03	-5.15E-03	-3.94E-03	-2.93E-03	-8.93E-04	2.00E-03
7	-2.41E-02	-1.09E-02	-3.17E-03	1.30E-03	4.26E-03	5.81E-03	7.18E-03	9.10E-03	1.27E-02	1.79E-02
8	-2.24E-03	5.48E-03	9.37E-03	1.07E-02	1.09E-02	1.10E-02	1.20E-02	1.37E-02	1.72E-02	2.34E-02
9	1.41E-02	1.55E-02	1.43E-02	1.14E-02	8.44E-03	5.89E-03	4.41E-03	5.04E-03	7.51E-03	1.30E-02
10	2.09E-02	1.53E-02	8.29E-03	6.21E-04	-6.51E-03	-1.26E-02	-1.72E-02	-1.94E-02	-1.94E-02	-1.64E-02

Low	1	2	3	4	5	6	7	8	9	10
1	2.78E-02	3.28E-02	3.52E-02	3.41E-02	3.02E-02	2.41E-02	1.64E-02	7.64E-03	-1.68E-03	-1.11E-02
2	-3.39E-02	-1.96E-02	-1.05E-02	-5.43E-03	-3.31E-03	-3.32E-03	-4.75E-03	-6.96E-03	-9.48E-03	-1.18E-02
3	-3.54E-02	-2.25E-02	-1.40E-02	-8.59E-03	-5.31E-03	-3.36E-03	-2.09E-03	-9.05E-04	6.81E-04	3.23E-03
4	-1.11E-02	-4.63E-03	-1.08E-03	7.71E-04	1.73E-03	2.41E-03	3.30E-03	4.97E-03	7.84E-03	1.25E-02
5	1.69E-02	1.37E-02	9.39E-03	4.83E-03	6.20E-04	-2.88E-03	-5.31E-03	-6.27E-03	-5.40E-03	-2.21E-03

High	1	2	3	4	5	6	7	8	9	10
6	-1.32E-03	2.09E-03	4.07E-03	5.24E-03	5.74E-03	5.51E-03	4.45E-03	2.38E-03	-2.71E-04	-4.53E-03
7	-7.46E-03	-4.90E-03	-3.35E-03	-2.10E-03	-6.54E-04	2.68E-05	2.58E-04	-9.42E-05	-7.32E-04	-2.70E-03
8	-5.54E-03	-4.55E-03	-3.67E-03	-3.00E-03	-2.12E-03	-1.16E-03	1.68E-04	8.24E-04	1.08E-03	7.48E-04
9	1.41E-03	1.17E-04	-7.66E-04	-1.40E-03	-1.37E-03	-8.66E-04	-6.06E-05	1.29E-03	2.10E-03	2.63E-03
10	1.04E-02	6.19E-03	2.88E-03	2.81E-04	-1.26E-03	-1.96E-03	-2.04E-03	-1.28E-03	-7.71E-04	-3.00E-04

10 MeV Al-Pb Exposure (Fractional Difference)

Full	1	2	3	4	5	6	7	8	9	10
1	0.090715	0.11507	0.137386	0.152251	0.158557	0.147506	0.135327	0.114927	0.086484	0.050276
2	-0.01982	0.006692	0.02946	0.045261	0.053641	0.05456	0.040055	0.025937	0.004962	-0.02288
3	-0.06969	-0.04551	-0.02442	-0.00898	0.000374	0.003762	0.00121	-0.00712	-0.02945	-0.04994
4	-0.08477	-0.06461	-0.04622	-0.03201	-0.02229	-0.01707	-0.01632	-0.01992	-0.0281	-0.04122
5	-0.07784	-0.06275	-0.04785	-0.03552	-0.02622	-0.01987	-0.01645	-0.01588	-0.01838	-0.02444
6	-0.05678	-0.04747	-0.03724	-0.02761	-0.01947	-0.01282	-0.00801	-0.00409	-0.00162	-0.00104
7	-0.02728	-0.02495	-0.02001	-0.0142	-0.00852	-0.003	0.002046	0.007675	0.01338	0.01882
8	0.005839	0.000333	-0.00108	-0.00033	0.00145	0.004167	0.007502	0.012516	0.018809	0.026105
9	0.038782	0.024514	0.015664	0.010051	0.006356	0.004371	0.003687	0.00532	0.008829	0.013942
10	0.068355	0.04451	0.027218	0.014005	0.003324	-0.00519	-0.01211	-0.01657	-0.01918	-0.02029

Low	1	2	3	4	5	6	7	8	9	10
1	9.56E-03	1.76E-02	2.93E-02	3.89E-02	4.46E-02	3.81E-02	3.38E-02	2.47E-02	1.07E-02	-8.36E-03
2	-4.37E-02	-3.44E-02	-2.25E-02	-1.22E-02	-4.35E-03	6.56E-04	-5.06E-03	-6.68E-03	-1.14E-02	-1.95E-02
3	-3.72E-02	-3.36E-02	-2.63E-02	-1.88E-02	-1.22E-02	-6.59E-03	-2.02E-03	1.62E-03	-4.10E-03	-3.18E-03
4	-7.78E-04	-6.95E-03	-7.59E-03	-6.42E-03	-4.34E-03	-1.66E-03	1.64E-03	5.77E-03	1.08E-02	1.66E-02
5	4.67E-02	2.77E-02	1.61E-02	7.86E-03	1.68E-03	-2.74E-03	-5.53E-03	-6.53E-03	-5.73E-03	-3.25E-03

High	1	2	3	4	5	6	7	8	9	10
6	-1.57E-02	-9.75E-03	-2.66E-03	3.78E-03	8.38E-03	1.09E-02	1.06E-02	8.23E-03	2.75E-03	-6.70E-03
7	-1.44E-02	-1.30E-02	-9.18E-03	-4.90E-03	-1.36E-03	1.19E-03	2.10E-03	2.08E-03	1.42E-04	-4.62E-03
8	-4.28E-03	-7.72E-03	-7.66E-03	-6.08E-03	-4.20E-03	-2.30E-03	-9.69E-04	4.94E-04	1.20E-03	2.30E-04
9	1.19E-02	3.12E-03	-1.10E-03	-2.80E-03	-3.28E-03	-2.85E-03	-2.07E-03	-2.15E-04	1.87E-03	3.35E-03
10	3.17E-02	1.71E-02	8.05E-03	2.42E-03	-1.22E-03	-3.18E-03	-4.07E-03	-3.14E-03	-1.23E-03	8.72E-04

Lead followed by Aluminum
65 keV Pb-Al Exposure (Fractional Difference)

Full	1	2	3	4	5	6	7	8	9	10
1	1.14E-02	1.76E-02	2.68E-02	3.07E-02	2.94E-02	2.41E-02	1.62E-02	6.97E-03	-2.80E-03	-1.23E-02
2	-1.46E-02	-4.96E-03	7.26E-03	1.41E-02	1.57E-02	1.34E-02	8.42E-03	2.11E-03	-4.71E-03	-1.12E-02
3	-2.77E-02	-1.82E-02	-5.09E-03	3.27E-03	6.74E-03	6.49E-03	3.80E-03	-1.26E-04	-4.46E-03	-8.32E-03
4	-3.13E-02	-2.44E-02	-1.19E-02	-3.17E-03	1.28E-03	2.42E-03	1.41E-03	-6.24E-04	-2.86E-03	-4.42E-03
5	-2.75E-02	-2.50E-02	-1.45E-02	-6.29E-03	-1.60E-03	3.10E-04	4.40E-04	-1.44E-04	-6.73E-04	-2.78E-04
6	-1.76E-02	-2.13E-02	-1.37E-02	-6.91E-03	-2.67E-03	-5.53E-04	2.76E-04	7.05E-04	1.49E-03	3.50E-03
7	-3.03E-03	-1.41E-02	-1.05E-02	-5.88E-03	-2.70E-03	-9.34E-04	6.55E-05	1.06E-03	2.77E-03	6.02E-03
8	1.52E-02	-4.53E-03	-5.67E-03	-3.86E-03	-2.31E-03	-1.39E-03	-6.91E-04	4.56E-04	2.67E-03	6.75E-03
9	3.60E-02	6.63E-03	8.00E-06	-1.58E-03	-2.19E-03	-2.60E-03	-2.63E-03	-1.77E-03	5.15E-04	4.99E-03
10	5.84E-02	1.86E-02	5.87E-03	3.52E-04	-2.87E-03	-5.05E-03	-6.24E-03	-6.09E-03	-4.14E-03	2.89E-04

Low	1	2	3	4	5	6	7	8	9	10
1	2.87E-04	-7.67E-04	6.23E-03	1.07E-02	1.15E-02	9.60E-03	5.96E-03	1.63E-03	-2.65E-03	-6.09E-03
2	-1.33E-02	-1.41E-02	-6.05E-03	-1.96E-05	2.82E-03	3.14E-03	1.92E-03	1.80E-04	-1.34E-03	-1.84E-03
3	-9.18E-03	-1.51E-02	-9.35E-03	-4.05E-03	-1.02E-03	9.34E-05	9.71E-05	-8.92E-05	2.34E-04	1.89E-03
4	8.16E-03	-7.02E-03	-6.07E-03	-3.43E-03	-1.75E-03	-1.13E-03	-1.02E-03	-6.34E-04	6.41E-04	3.59E-03
5	3.53E-02	7.76E-03	1.74E-03	1.07E-04	-9.07E-04	-1.93E-03	-2.74E-03	-2.74E-03	-1.42E-03	1.92E-03

High	1	2	3	4	5	6	7	8	9	10
6	-8.39E-03	-9.02E-03	-1.09E-03	4.57E-03	6.78E-03	6.26E-03	4.05E-03	1.15E-03	-1.63E-03	-3.41E-03
7	-5.16E-03	-9.98E-03	-3.96E-03	1.00E-03	3.25E-03	3.26E-03	1.93E-03	1.87E-04	-1.18E-03	-1.31E-03
8	1.92E-03	-8.03E-03	-4.55E-03	-8.02E-04	1.07E-03	1.24E-03	4.75E-04	-3.78E-04	-5.82E-04	7.30E-04
9	1.20E-02	-3.87E-03	-3.51E-03	-1.42E-03	-3.17E-04	-3.18E-04	-8.11E-04	-1.05E-03	-3.48E-04	2.16E-03
10	2.45E-02	1.98E-03	-1.29E-03	-1.28E-03	-1.30E-03	-1.79E-03	-2.32E-03	-2.22E-03	-8.53E-04	2.61E-03

100 keV Pb-AI Exposure (Fractional Difference)

Full	1	2	3	4	5	6	7	8	9	10
1	7.43E-02	1.14E-01	1.21E-01	1.09E-01	8.82E-02	6.47E-02	4.26E-02	2.44E-02	1.15E-02	5.16E-03
2	-5.12E-02	3.13E-03	2.00E-02	1.53E-02	-3.17E-04	-2.02E-02	-4.00E-02	-5.73E-02	-7.03E-02	-7.79E-02
3	-9.29E-02	-3.31E-02	-9.88E-03	-9.69E-03	-2.23E-02	-4.07E-02	-6.03E-02	-7.82E-02	-9.26E-02	-1.02E-01
4	-9.42E-02	-3.45E-02	-5.30E-03	1.17E-03	-6.72E-03	-2.23E-02	-4.07E-02	-5.87E-02	-7.41E-02	-8.53E-02
5	-7.49E-02	-2.30E-02	1.02E-02	2.44E-02	2.43E-02	1.50E-02	1.01E-03	-1.43E-02	-2.82E-02	-3.91E-02
6	-4.56E-02	-1.16E-02	2.00E-02	4.05E-02	4.99E-02	5.06E-02	4.56E-02	3.77E-02	2.95E-02	2.31E-02
7	-1.15E-02	-6.60E-03	1.46E-02	3.57E-02	5.25E-02	6.40E-02	7.12E-02	7.53E-02	7.82E-02	8.17E-02
8	2.64E-02	-8.29E-03	-7.16E-03	6.06E-03	2.35E-02	4.17E-02	5.96E-02	7.68E-02	9.40E-02	1.12E-01
9	6.94E-02	-1.35E-02	-4.02E-02	-4.31E-02	-3.34E-02	-1.61E-02	6.07E-03	3.19E-02	6.08E-02	9.28E-02
10	1.20E-01	-1.75E-02	-7.72E-02	-1.02E-01	-1.06E-01	-9.73E-02	-7.88E-02	-5.24E-02	-1.92E-02	2.06E-02

Low	1	2	3	4	5	6	7	8	9	10
1	1.83E-02	1.04E-02	5.55E-03	-8.89E-04	-7.24E-03	-1.11E-02	-1.03E-02	-3.10E-03	1.24E-02	3.79E-02
2	-2.43E-02	-6.32E-03	-2.13E-03	-6.01E-03	-1.29E-02	-1.89E-02	-2.14E-02	-1.81E-02	-7.22E-03	1.29E-02
3	-1.48E-02	1.13E-02	1.89E-02	1.50E-02	5.77E-03	-4.05E-03	-1.12E-02	-1.33E-02	-8.57E-03	4.74E-03
4	-7.40E-03	2.03E-02	3.21E-02	3.12E-02	2.30E-02	1.21E-02	2.15E-03	-4.05E-03	-4.52E-03	2.50E-03
5	-3.88E-02	-1.36E-02	4.56E-03	1.17E-02	1.04E-02	4.40E-03	-2.99E-03	-8.95E-03	-1.11E-02	-7.67E-03

High	1	2	3	4	5	6	7	8	9	10
6	-1.72E-01	-1.50E-01	-1.27E-01	-1.11E-01	-1.04E-01	-1.04E-01	-1.09E-01	-1.17E-01	-1.27E-01	-1.35E-01
7	-1.40E-01	-1.45E-01	-1.37E-01	-1.28E-01	-1.24E-01	-1.25E-01	-1.31E-01	-1.40E-01	-1.52E-01	-1.65E-01
8	-1.35E-01	-1.57E-01	-1.55E-01	-1.48E-01	-1.40E-01	-1.35E-01	-1.33E-01	-1.34E-01	-1.38E-01	-1.44E-01
9	-1.32E-01	-1.70E-01	-1.76E-01	-1.71E-01	-1.62E-01	-1.51E-01	-1.42E-01	-1.33E-01	-1.27E-01	-1.21E-01
10	-1.15E-01	-1.71E-01	-1.87E-01	-1.88E-01	-1.82E-01	-1.71E-01	-1.57E-01	-1.43E-01	-1.27E-01	-1.12E-01

500 keV Pb-Al Exposure (Fractional Difference)

Full	1	2	3	4	5	6	7	8	9	10
1	4.30E-03	6.13E-02	8.02E-02	8.11E-02	7.28E-02	5.97E-02	4.39E-02	2.64E-02	7.80E-03	-1.19E-02
2	-6.49E-02	-2.62E-03	2.37E-02	3.23E-02	3.18E-02	2.60E-02	1.70E-02	5.99E-03	-6.71E-03	-2.10E-02
3	-9.23E-02	-3.42E-02	-6.85E-03	5.10E-03	8.70E-03	7.52E-03	3.35E-03	-3.01E-03	-1.12E-02	-2.12E-02
4	-9.51E-02	-4.60E-02	-2.11E-02	-8.63E-03	-2.94E-03	-1.16E-03	-1.97E-03	-4.75E-03	-9.27E-03	-1.57E-02
5	-8.11E-02	-4.48E-02	-2.47E-02	-1.35E-02	-7.24E-03	-3.78E-03	-2.25E-03	-2.28E-03	-3.84E-03	-7.22E-03
6	-5.53E-02	-3.44E-02	-2.12E-02	-1.28E-02	-7.23E-03	-3.15E-03	-1.64E-04	1.84E-03	2.61E-03	1.71E-03
7	-2.15E-02	-1.80E-02	-1.32E-02	-9.09E-03	-5.30E-03	-1.55E-03	2.03E-03	5.26E-03	7.71E-03	8.73E-03
8	1.71E-02	1.53E-03	-3.50E-03	-4.66E-03	-3.68E-03	-1.22E-03	2.12E-03	5.79E-03	9.14E-03	1.14E-02
9	5.78E-02	2.18E-02	5.99E-03	-1.48E-03	-4.24E-03	-3.97E-03	-1.77E-03	1.48E-03	4.94E-03	7.70E-03
10	9.79E-02	4.08E-02	1.34E-02	-1.19E-03	-8.55E-03	-1.13E-02	-1.11E-02	-9.18E-03	-6.49E-03	-4.10E-03

Low	1	2	3	4	5	6	7	8	9	10
1	-2.43E-02	1.08E-02	2.45E-02	2.77E-02	2.55E-02	2.07E-02	1.42E-02	6.56E-03	-2.21E-03	-1.24E-02
2	-5.81E-02	-2.56E-02	-9.38E-03	-1.74E-03	1.57E-03	2.55E-03	2.09E-03	4.96E-04	-2.35E-03	-6.83E-03
3	-4.14E-02	-2.54E-02	-1.58E-02	-1.01E-02	-6.21E-03	-3.24E-03	-7.90E-04	1.05E-03	1.95E-03	1.37E-03
4	5.36E-03	-3.81E-03	-6.53E-03	-7.07E-03	-6.22E-03	-4.20E-03	-1.43E-03	1.59E-03	4.28E-03	5.86E-03
5	6.97E-02	2.95E-02	1.04E-02	3.01E-04	-4.60E-03	-6.06E-03	-5.28E-03	-3.19E-03	-7.09E-04	1.19E-03

High	1	2	3	4	5	6	7	8	9	10
6	-3.62E-02	-1.03E-02	2.55E-03	7.99E-03	9.41E-03	8.61E-03	6.44E-03	3.29E-03	-8.28E-04	-6.11E-03
7	-2.58E-02	-1.08E-02	-2.45E-03	1.42E-03	2.86E-03	3.08E-03	2.50E-03	1.32E-03	-5.60E-04	-3.51E-03
8	-8.79E-03	-5.87E-03	-3.13E-03	-1.65E-03	-8.49E-04	-2.26E-04	3.00E-04	6.62E-04	5.98E-04	-3.11E-04
9	1.31E-02	2.71E-03	-9.35E-04	-2.57E-03	-3.05E-03	-2.58E-03	-1.46E-03	-5.44E-06	1.38E-03	2.15E-03
10	3.82E-02	1.36E-02	2.78E-03	-2.62E-03	-4.96E-03	-5.19E-03	-3.98E-03	-1.89E-03	5.17E-04	2.58E-03

1 MeV Pb-Al Exposure (Fractional Difference)

Full	1	2	3	4	5	6	7	8	9	10
1	9.32E-02	1.11E-01	1.08E-01	9.44E-02	7.68E-02	5.76E-02	3.82E-02	1.95E-02	1.85E-03	-1.46E-02
2	-1.48E-02	2.26E-02	3.61E-02	3.68E-02	3.10E-02	2.17E-02	1.09E-02	-3.62E-04	-1.15E-02	-2.23E-02
3	-6.28E-02	-2.15E-02	-1.76E-03	5.68E-03	6.28E-03	3.06E-03	-2.21E-03	-8.45E-03	-1.50E-02	-2.16E-02
4	-7.79E-02	-3.97E-02	-1.89E-02	-8.71E-03	-4.70E-03	-4.30E-03	-5.96E-03	-8.69E-03	-1.19E-02	-1.52E-02
5	-7.26E-02	-4.15E-02	-2.28E-02	-1.23E-02	-6.94E-03	-4.58E-03	-3.96E-03	-4.28E-03	-5.01E-03	-5.85E-03
6	-5.40E-02	-3.30E-02	-1.85E-02	-9.64E-03	-4.35E-03	-1.24E-03	6.10E-04	1.83E-03	2.82E-03	3.83E-03
7	-2.75E-02	-1.86E-02	-1.02E-02	-4.31E-03	-3.14E-04	2.52E-03	4.74E-03	6.76E-03	8.85E-03	1.11E-02
8	2.55E-03	-2.49E-03	-1.45E-03	3.35E-04	2.08E-03	3.81E-03	5.66E-03	7.81E-03	1.04E-02	1.34E-02
9	3.20E-02	1.19E-02	4.62E-03	1.43E-03	1.48E-04	4.27E-05	8.82E-04	2.56E-03	5.05E-03	8.30E-03
10	5.71E-02	2.15E-02	5.27E-03	-3.48E-03	-8.38E-03	-1.09E-02	-1.16E-02	-1.09E-02	-9.04E-03	-6.09E-03
Low	1	2	3	4	5	6	7	8	9	10
1	1.57E+00	2.33E-01	3.57E-01	2.11E-01	1.04E-01	3.63E-02	1.46E-04	-6.62E-03	1.78E-02	8.15E-02
2	9.27E-01	-7.29E-04	2.61E-01	1.11E-01	1.63E-02	-4.01E-02	-6.61E-02	-6.39E-02	-3.08E-02	4.28E-02
3	6.38E-01	1.92E-01	1.98E-01	3.44E-02	-5.07E-02	-9.70E-02	-1.14E-01	-1.02E-01	-5.86E-02	2.94E-02
4	4.83E-01	1.51E-01	2.60E-01	-2.08E-02	-9.88E-02	-1.35E-01	-1.42E-01	-1.20E-01	-6.18E-02	4.86E-02
5	3.83E-01	1.04E-01	-1.40E-01	-3.16E-02	-1.21E-01	-1.49E-01	-1.45E-01	-1.08E-01	-2.83E-02	1.22E-01
High	1	2	3	4	5	6	7	8	9	10
6	-1.27E-02	-2.02E-03	5.03E-03	7.96E-03	8.09E-03	6.50E-03	3.93E-03	8.88E-04	-2.30E-03	-5.45E-03
7	-1.29E-02	-7.00E-03	-1.43E-03	1.54E-03	2.54E-03	2.27E-03	1.27E-03	-6.00E-05	-1.46E-03	-2.81E-03
8	-5.78E-03	-6.06E-03	-3.13E-03	-1.04E-03	5.46E-05	4.33E-04	4.35E-04	3.09E-04	2.44E-04	3.32E-04
9	6.05E-03	-1.57E-03	-2.19E-03	-1.73E-03	-1.20E-03	-7.41E-04	-2.33E-04	4.22E-04	1.32E-03	2.49E-03
10	2.02E-02	4.30E-03	-6.10E-04	-2.42E-03	-3.01E-03	-2.95E-03	-2.36E-03	-1.32E-03	1.85E-04	2.13E-03

2 MeV Pb-Al Exposure (Fractional Difference)

Full	1	2	3	4	5	6	7	8	9	10
1	1.23E-01	1.13E-01	9.71E-02	7.82E-02	5.85E-02	3.92E-02	2.11E-02	4.50E-03	-1.04E-02	-2.36E-02
2	7.69E-03	2.67E-02	3.27E-02	3.04E-02	2.35E-02	1.45E-02	4.59E-03	-5.27E-03	-1.46E-02	-2.31E-02
3	-4.56E-02	-1.78E-02	-2.50E-03	3.79E-03	4.44E-03	1.80E-03	-2.57E-03	-7.71E-03	-1.30E-02	-1.79E-02
4	-6.37E-02	-3.65E-02	-1.85E-02	-8.35E-03	-3.69E-03	-2.48E-03	-3.31E-03	-5.24E-03	-7.57E-03	-9.84E-03
5	-5.99E-02	-3.86E-02	-2.18E-02	-1.10E-02	-4.71E-03	-1.53E-03	-3.01E-04	-1.98E-04	-5.41E-04	-9.22E-04
6	-4.25E-02	-3.04E-02	-1.75E-02	-8.13E-03	-1.97E-03	1.77E-03	3.93E-03	5.18E-03	6.07E-03	6.97E-03
7	-1.79E-02	-1.70E-02	-9.86E-03	-3.37E-03	1.42E-03	4.71E-03	6.98E-03	8.66E-03	1.02E-02	1.19E-02
8	8.45E-03	-2.93E-03	-2.58E-03	3.60E-05	2.62E-03	4.76E-03	6.52E-03	8.13E-03	9.86E-03	1.19E-02
9	3.21E-02	8.12E-03	1.27E-03	-4.75E-04	-5.36E-04	-1.96E-06	8.70E-04	2.04E-03	3.65E-03	5.84E-03
10	4.91E-02	1.31E-02	-8.16E-04	-6.99E-03	-9.88E-03	-1.11E-02	-1.14E-02	-1.08E-02	-9.54E-03	-7.50E-03

Low	1	2	3	4	5	6	7	8	9	10
1	2.94E-02	3.15E-02	2.98E-02	2.50E-02	1.86E-02	1.16E-02	4.61E-03	-2.01E-03	-8.03E-03	-1.34E-02
2	-3.43E-02	-1.81E-02	-7.35E-03	-1.64E-03	7.28E-04	1.09E-03	3.58E-04	-9.19E-04	-2.34E-03	-3.69E-03
3	-3.32E-02	-2.43E-02	-1.47E-02	-7.68E-03	-3.08E-03	-1.64E-04	1.69E-03	2.90E-03	3.82E-03	4.66E-03
4	-1.55E-03	-9.15E-03	-7.60E-03	-4.64E-03	-1.92E-03	2.94E-04	2.12E-03	3.68E-03	5.17E-03	6.72E-03
5	3.97E-02	1.20E-02	2.28E-03	-1.59E-03	-3.15E-03	-3.68E-03	-3.64E-03	-3.23E-03	-2.44E-03	-1.31E-03

High	1	2	3	4	5	6	7	8	9	10
6	-5.23E-03	2.92E-04	5.90E-03	8.20E-03	7.71E-03	5.45E-03	2.31E-03	-1.03E-03	-4.05E-03	-6.40E-03
7	-8.78E-03	-6.10E-03	-8.42E-04	2.27E-03	3.15E-03	2.51E-03	1.10E-03	-5.18E-04	-1.83E-03	-2.51E-03
8	-4.47E-03	-6.46E-03	-3.03E-03	-3.03E-04	9.62E-04	1.16E-03	8.13E-04	3.99E-04	3.47E-04	9.34E-04
9	4.65E-03	-3.36E-03	-2.81E-03	-1.36E-03	-4.11E-04	-3.02E-06	2.17E-04	5.74E-04	1.43E-03	3.07E-03
10	1.56E-02	7.21E-04	-2.36E-03	-2.79E-03	-2.70E-03	-2.51E-03	-2.10E-03	-1.29E-03	1.96E-04	2.55E-03

6 MeV Pb-Al Exposure (Fractional Difference)

Full	1	2	3	4	5	6	7	8	9	10
1	3.49E-02	4.69E-02	4.20E-02	3.13E-02	1.99E-02	1.03E-02	3.68E-03	7.99E-04	2.04E-03	7.73E-03
2	-2.47E-02	4.08E-03	1.01E-02	6.87E-03	8.42E-04	-4.70E-03	-8.06E-03	-8.31E-03	-4.83E-03	2.78E-03
3	-4.24E-02	-1.17E-02	-2.58E-03	-3.19E-03	-7.03E-03	-1.08E-02	-1.27E-02	-1.16E-02	-7.02E-03	1.58E-03
4	-3.74E-02	-1.10E-02	-2.86E-03	-3.53E-03	-7.19E-03	-1.07E-02	-1.23E-02	-1.09E-02	-6.09E-03	2.76E-03
5	-2.28E-02	-2.37E-03	3.36E-03	1.47E-03	-2.94E-03	-6.96E-03	-8.93E-03	-7.95E-03	-3.41E-03	5.15E-03
6	-7.87E-03	7.53E-03	1.11E-02	8.01E-03	2.71E-03	-2.05E-03	-4.69E-03	-4.33E-03	-3.98E-04	7.55E-03
7	1.53E-03	1.39E-02	1.66E-02	1.30E-02	7.23E-03	1.98E-03	-1.24E-03	-1.44E-03	1.74E-03	8.94E-03
8	2.02E-03	1.38E-02	1.71E-02	1.42E-02	8.77E-03	3.52E-03	7.24E-05	-5.52E-04	2.12E-03	8.59E-03
9	-7.80E-03	5.56E-03	1.12E-02	1.01E-02	5.91E-03	1.43E-03	-1.75E-03	-2.51E-03	-1.89E-04	5.69E-03
10	-2.77E-02	-1.11E-02	-1.87E-03	1.27E-05	-1.98E-03	-5.05E-03	-7.40E-03	-7.81E-03	-5.53E-03	-1.81E-05

Low	1	2	3	4	5	6	7	8	9	10
1	3.46E-02	1.85E-02	9.97E-03	4.59E-03	1.01E-03	-1.26E-03	-2.44E-03	-2.66E-03	-1.98E-03	-4.27E-04
2	-1.09E-02	-7.13E-03	-5.31E-03	-4.61E-03	-4.22E-03	-3.71E-03	-2.82E-03	-1.41E-03	6.12E-04	3.27E-03
3	-1.81E-02	-8.69E-03	-4.15E-03	-2.32E-03	-1.58E-03	-1.08E-03	-3.75E-04	8.67E-04	2.62E-03	5.02E-03
4	-1.07E-02	-9.76E-04	3.06E-03	3.69E-03	2.94E-03	1.89E-03	1.08E-03	9.22E-04	1.38E-03	2.58E-03
5	-4.21E-03	4.98E-03	8.04E-03	7.08E-03	4.40E-03	1.35E-03	-1.38E-03	-3.48E-03	-4.79E-03	-5.25E-03

High	1	2	3	4	5	6	7	8	9	10
6	-1.39E-02	2.78E-03	7.36E-03	5.07E-03	4.98E-04	-3.55E-03	-5.47E-03	-4.34E-03	4.35E-04	9.33E-03
7	-7.22E-03	5.56E-03	8.64E-03	5.48E-03	2.06E-04	-4.55E-03	-7.23E-03	-6.86E-03	-3.05E-03	4.86E-03
8	-4.53E-03	6.93E-03	1.01E-02	7.17E-03	1.87E-03	-3.17E-03	-6.34E-03	-6.62E-03	-3.54E-03	3.42E-03
9	-7.79E-03	4.64E-03	9.56E-03	7.98E-03	3.52E-03	-1.11E-03	-4.31E-03	-4.99E-03	-2.48E-03	3.69E-03
10	-1.76E-02	-2.40E-03	5.64E-03	6.58E-03	3.85E-03	2.37E-04	-2.47E-03	-3.07E-03	-8.08E-04	4.83E-03

10 MeV Pb-Al Exposure (Fractional Difference)

Full	1	2	3	4	5	6	7	8	9	10
1	-2.64E-02	6.83E-02	7.17E-02	5.18E-02	2.86E-02	8.99E-03	-4.54E-03	-1.11E-02	-1.01E-02	-1.05E-03
2	-6.62E-02	3.42E-02	4.61E-02	3.25E-02	1.39E-02	-2.26E-03	-1.31E-02	-1.74E-02	-1.45E-02	-3.76E-03
3	-7.35E-02	1.75E-02	3.15E-02	2.10E-02	5.22E-03	-8.68E-03	-1.76E-02	-2.03E-02	-1.59E-02	-3.80E-03
4	-6.14E-02	1.26E-02	2.47E-02	1.54E-02	1.22E-03	-1.12E-02	-1.88E-02	-2.02E-02	-1.47E-02	-1.49E-03
5	-3.99E-02	1.42E-02	2.27E-02	1.36E-02	3.82E-04	-1.09E-02	-1.75E-02	-1.80E-02	-1.15E-02	2.63E-03
6	-1.70E-02	1.77E-02	2.25E-02	1.35E-02	1.18E-03	-9.06E-03	-1.47E-02	-1.43E-02	-6.95E-03	8.03E-03
7	1.05E-03	1.91E-02	2.11E-02	1.29E-02	2.00E-03	-6.95E-03	-1.14E-02	-1.00E-02	-1.83E-03	1.40E-02
8	9.62E-03	1.52E-02	1.64E-02	1.01E-02	1.46E-03	-5.59E-03	-8.53E-03	-5.90E-03	3.35E-03	2.01E-02
9	5.82E-03	3.66E-03	6.37E-03	3.53E-03	-1.87E-03	-6.24E-03	-7.09E-03	-2.82E-03	7.75E-03	2.56E-02
10	-1.18E-02	-1.69E-02	-1.04E-02	-8.30E-03	-9.22E-03	-9.99E-03	-8.06E-03	-1.64E-03	1.06E-02	2.99E-02

Low	1	2	3	4	5	6	7	8	9	10
1	2.63E-02	1.92E-02	9.34E-03	7.17E-04	-5.58E-03	-9.00E-03	-9.20E-03	-5.97E-03	9.17E-04	1.17E-02
2	-1.44E-02	2.41E-03	2.39E-03	-2.18E-03	-6.82E-03	-9.64E-03	-9.80E-03	-6.79E-03	-2.60E-04	1.00E-02
3	-2.39E-02	5.56E-03	1.02E-02	6.34E-03	6.67E-04	-3.89E-03	-5.99E-03	-4.99E-03	-4.94E-04	7.71E-03
4	-2.92E-02	1.06E-02	1.97E-02	1.63E-02	9.25E-03	2.43E-03	-2.29E-03	-4.06E-03	-2.40E-03	2.87E-03
5	-4.56E-02	5.38E-03	2.10E-02	1.99E-02	1.27E-02	4.42E-03	-2.51E-03	-6.88E-03	-8.10E-03	-5.91E-03

High	1	2	3	4	5	6	7	8	9	10
6	-3.45E-02	1.45E-02	2.63E-02	2.07E-02	9.74E-03	-5.23E-04	-7.08E-03	-8.39E-03	-3.53E-03	8.21E-03
7	-1.52E-02	1.13E-02	1.83E-02	1.27E-02	2.76E-03	-6.41E-03	-1.20E-02	-1.26E-02	-7.20E-03	4.90E-03
8	-2.36E-03	8.50E-03	1.30E-02	8.20E-03	-2.61E-04	-8.08E-03	-1.26E-02	-1.24E-02	-6.43E-03	6.07E-03
9	2.46E-03	3.45E-03	7.63E-03	4.98E-03	-1.20E-03	-7.14E-03	-1.03E-02	-9.02E-03	-2.27E-03	1.08E-02
10	-1.20E-03	-5.56E-03	4.43E-04	1.27E-03	-1.65E-03	-4.98E-03	-6.16E-03	-3.44E-03	4.39E-03	1.83E-02

Polyethylene followed by Lead

65 keV Poly-Pb Exposure (Fractional Difference)

Full	1	2	3	4	5	6	7	8	9	10
1	1.42E-01	1.23E-01	8.91E-02	6.29E-02	4.60E-02	3.79E-02	3.79E-02	4.60E-02	6.20E-02	8.68E-02
2	7.31E-03	4.05E-02	2.70E-02	1.16E-02	1.60E-03	2.26E-03	5.85E-03	1.70E-02	3.58E-02	6.26E-02
3	-5.19E-02	2.40E-03	-3.74E-03	-1.53E-02	-2.27E-02	-2.01E-02	-1.48E-02	-2.17E-03	1.80E-02	4.62E-02
4	-6.64E-02	-6.84E-03	-1.34E-02	-2.56E-02	-3.35E-02	-3.11E-02	-2.57E-02	-1.28E-02	7.78E-03	3.65E-02
5	-5.42E-02	1.80E-03	-9.38E-03	-2.48E-02	-3.49E-02	-3.40E-02	-2.95E-02	-1.73E-02	2.85E-03	3.15E-02
6	-2.86E-02	1.92E-02	1.75E-03	-1.79E-02	-3.09E-02	-3.21E-02	-2.90E-02	-1.79E-02	1.20E-03	2.93E-02
7	-1.78E-03	3.73E-02	1.42E-02	-9.33E-03	-2.51E-02	-2.83E-02	-2.69E-02	-1.72E-02	7.72E-04	2.81E-02
8	1.48E-02	4.90E-02	2.30E-02	-2.88E-03	-1.64E-02	-2.53E-02	-2.54E-02	-1.70E-02	-2.92E-04	2.60E-02
9	1.09E-02	4.85E-02	2.39E-02	-1.85E-03	-2.01E-02	-2.56E-02	-2.65E-02	-1.92E-02	-3.46E-03	2.19E-02
10	-2.00E-02	3.20E-02	1.42E-02	-8.60E-03	-2.56E-02	-3.07E-02	-3.19E-02	-2.52E-02	-1.03E-02	1.41E-02

Low	1	2	3	4	5	6	7	8	9	10
1	-5.26E-03	2.16E-02	1.57E-02	6.11E-03	-1.31E-03	-4.95E-03	-4.24E-03	1.39E-03	1.20E-02	2.81E-02
2	-4.01E-02	8.02E-03	5.73E-03	-3.16E-03	-1.03E-02	-9.75E-03	-8.59E-03	-2.17E-03	9.53E-03	2.66E-02
3	-2.44E-02	2.16E-02	1.31E-02	-1.79E-04	-1.01E-02	-1.12E-02	-1.10E-02	-4.94E-03	6.69E-03	2.39E-02
4	-5.80E-04	3.78E-02	2.15E-02	2.87E-03	-1.06E-02	-1.40E-02	-1.53E-02	-1.04E-02	4.19E-04	1.71E-02
5	-8.42E-03	3.46E-02	1.67E-02	-3.92E-03	-1.92E-02	-2.41E-02	-2.65E-02	-2.27E-02	-1.30E-02	2.85E-03

High	1	2	3	4	5	6	7	8	9	10
6	-2.33E-03	-1.26E-02	-9.89E-03	-5.26E-03	2.24E-04	1.10E-02	1.93E-02	2.96E-02	4.19E-02	5.67E-02
7	1.20E-03	-4.45E-03	-9.26E-03	-1.15E-02	-1.14E-02	-4.85E-03	1.13E-04	7.50E-03	1.72E-02	2.98E-02
8	1.09E-03	5.99E-03	-2.99E-03	-1.06E-02	-1.10E-02	-1.26E-02	-1.10E-02	-6.60E-03	4.01E-04	1.06E-02
9	-1.35E-03	1.67E-02	6.15E-03	-5.31E-03	-1.39E-02	-1.47E-02	-1.63E-02	-1.48E-02	-1.03E-02	-2.33E-03
10	-4.57E-03	2.69E-02	1.66E-02	2.53E-03	-9.14E-03	-1.30E-02	-1.74E-02	-1.85E-02	-1.65E-02	-1.08E-02

100 keV Poly-Pb Exposure (Fractional Difference)

Full	1	2	3	4	5	6	7	8	9	10
1	2.58E-01	3.16E-01	3.31E-01	3.12E-01	2.69E-01	2.08E-01	1.42E-01	8.25E-02	4.31E-02	3.90E-02
2	-4.02E-02	6.58E-02	1.04E-01	9.84E-02	5.87E-02	8.03E-03	-4.42E-02	-8.47E-02	-9.95E-02	-7.14E-02
3	-1.83E-01	-5.33E-02	-4.14E-03	-4.00E-03	-3.73E-02	-7.94E-02	-1.19E-01	-1.41E-01	-1.31E-01	-6.48E-02
4	-2.41E-01	-9.12E-02	-3.38E-02	-2.95E-02	-5.86E-02	-9.39E-02	-1.22E-01	-1.28E-01	-9.15E-02	1.86E-02
5	-2.47E-01	-7.59E-02	-1.12E-02	-5.26E-03	-3.32E-02	-6.52E-02	-8.62E-02	-7.81E-02	-1.77E-02	1.37E-01
6	-2.21E-01	-2.65E-02	4.33E-02	4.72E-02	1.55E-02	-1.83E-02	-3.76E-02	-2.26E-02	5.29E-02	2.39E-01
7	-1.79E-01	3.92E-02	1.10E-01	1.06E-01	6.45E-02	2.22E-02	-3.32E-03	7.91E-03	8.22E-02	2.69E-01
8	-1.35E-01	1.02E-01	1.67E-01	1.50E-01	9.20E-02	3.45E-02	-5.44E-03	-9.55E-03	4.47E-02	1.99E-01
9	-1.05E-01	1.43E-01	1.97E-01	1.60E-01	8.26E-02	5.70E-03	-5.39E-02	-8.09E-02	-5.92E-02	3.96E-02
10	-9.86E-02	1.50E-01	1.87E-01	1.29E-01	3.14E-02	-6.45E-02	-1.44E-01	-1.94E-01	-2.06E-01	-1.64E-01

Low	1	2	3	4	5	6	7	8	9	10
1	1.10E-01	1.24E-01	1.16E-01	9.51E-02	6.52E-02	3.07E-02	-2.09E-03	-2.59E-02	-3.26E-02	-1.26E-02
2	-1.01E-01	-2.76E-02	-3.29E-03	-5.18E-03	-2.54E-02	-4.61E-02	-6.16E-02	-6.18E-02	-3.54E-02	3.30E-02
3	-1.63E-01	-5.05E-02	-7.40E-03	-1.54E-04	-1.53E-02	-3.13E-02	-3.99E-02	-2.92E-02	1.46E-02	1.10E-01
4	-1.49E-01	-1.52E-03	5.34E-02	6.04E-02	3.84E-02	1.27E-02	-6.87E-03	-8.47E-03	1.97E-02	9.28E-02
5	-1.03E-01	7.46E-02	1.31E-01	1.24E-01	7.99E-02	2.73E-02	-2.30E-02	-6.06E-02	-7.78E-02	-6.72E-02

High	1	2	3	4	5	6	7	8	9	10
6	4.00E-03	1.13E-01	1.01E-01	4.27E-02	-3.07E-02	-8.95E-02	-1.24E-01	-1.25E-01	-8.35E-02	2.13E-03
7	-8.09E-02	4.86E-02	5.63E-02	1.43E-02	-4.42E-02	-9.05E-02	-1.15E-01	-1.10E-01	-6.99E-02	5.81E-04
8	-1.33E-01	1.65E-02	4.11E-02	1.30E-02	-3.46E-02	-7.29E-02	-9.33E-02	-8.92E-02	-6.02E-02	-1.69E-02
9	-1.63E-01	6.39E-03	4.63E-02	2.93E-02	-1.09E-02	-4.56E-02	-6.72E-02	-7.15E-02	-6.16E-02	-5.26E-02
10	-1.78E-01	1.14E-02	6.52E-02	5.67E-02	2.02E-02	-1.54E-02	-4.37E-02	-6.22E-02	-7.69E-02	-1.04E-01

500 keV Poly-Pb Exposure (Fractional Difference)

Full	1	2	3	4	5	6	7	8	9	10
1	3.94E-02	7.34E-02	6.77E-02	5.13E-02	3.33E-02	1.71E-02	4.16E-03	-4.94E-03	-9.43E-03	-9.12E-03
2	-3.38E-02	1.99E-02	2.82E-02	2.22E-02	1.21E-02	2.18E-03	-5.65E-03	-1.04E-02	-1.12E-02	-7.45E-03
3	-5.61E-02	-3.28E-03	8.22E-03	6.36E-03	3.20E-04	-6.11E-03	-1.06E-02	-1.22E-02	-1.01E-02	-3.74E-03
4	-4.97E-02	-7.48E-03	1.33E-03	-1.84E-04	-4.74E-03	-9.09E-03	-1.17E-02	-1.13E-02	-7.16E-03	1.21E-03
5	-2.92E-02	-1.04E-03	2.36E-03	-8.65E-04	-5.45E-03	-9.22E-03	-1.06E-02	-8.77E-03	-3.26E-03	6.58E-03
6	-5.89E-03	9.28E-03	6.85E-03	1.25E-03	-4.05E-03	-7.69E-03	-8.26E-03	-5.82E-03	6.71E-04	1.16E-02
7	1.13E-02	1.79E-02	1.11E-02	3.53E-03	-2.49E-03	-6.01E-03	-6.40E-03	-3.41E-03	3.78E-03	1.55E-02
8	1.61E-02	2.07E-02	1.23E-02	3.83E-03	-2.44E-03	-5.81E-03	-5.87E-03	-2.41E-03	5.31E-03	1.76E-02
9	5.36E-03	1.52E-02	8.26E-03	1.31E-03	-5.84E-03	-8.33E-03	-7.51E-03	-3.01E-03	5.55E-03	1.68E-02
10	-2.03E-02	1.15E-03	-2.74E-03	-7.61E-03	-1.14E-02	-1.28E-02	-1.12E-02	-7.82E-03	1.24E-03	1.47E-02

Low	1	2	3	4	5	6	7	8	9	10
1	-1.61E-02	2.83E-02	2.96E-02	1.93E-02	7.22E-03	-2.91E-03	-9.43E-03	-1.16E-02	-8.39E-03	6.69E-04
2	-3.60E-02	8.56E-03	1.37E-02	7.76E-03	-3.08E-04	-6.90E-03	-1.03E-02	-9.58E-03	-3.67E-03	8.01E-03
3	-1.92E-02	1.21E-02	1.29E-02	6.15E-03	-1.39E-03	-7.10E-03	-9.20E-03	-6.94E-03	3.83E-04	1.35E-02
4	-3.63E-03	1.82E-02	1.47E-02	6.26E-03	-1.80E-03	-7.24E-03	-9.13E-03	-6.39E-03	1.47E-03	1.51E-02
5	-9.85E-03	1.38E-02	1.04E-02	1.93E-03	-5.98E-03	-1.14E-02	-1.29E-02	-1.00E-02	-2.11E-03	1.14E-02

High	1	2	3	4	5	6	7	8	9	10
6	-1.38E-02	1.62E-03	7.03E-03	7.65E-03	6.15E-03	4.14E-03	3.37E-03	3.99E-03	7.17E-03	1.33E-02
7	-3.26E-03	2.58E-03	2.55E-03	6.01E-04	-1.91E-03	-3.94E-03	-4.65E-03	-3.58E-03	1.35E-04	6.77E-03
8	2.18E-03	5.84E-03	2.63E-03	-1.33E-03	-4.92E-03	-7.42E-03	-8.26E-03	-7.10E-03	-3.21E-03	3.64E-03
9	1.19E-03	8.82E-03	4.87E-03	5.78E-04	-5.25E-03	-7.86E-03	-8.59E-03	-7.02E-03	-2.80E-03	2.67E-03
10	-5.85E-03	1.08E-02	6.79E-03	2.21E-03	-2.07E-03	-4.96E-03	-5.90E-03	-6.24E-03	-2.12E-03	5.03E-03

1 MeV Poly-Pb Exposure (Fractional Difference)

Full	1	2	3	4	5	6	7	8	9	10
1	7.54E-02	8.41E-02	6.99E-02	5.04E-02	3.14E-02	1.55E-02	3.89E-03	-3.03E-03	-4.65E-03	-5.83E-04
2	-2.18E-02	1.85E-02	2.30E-02	1.59E-02	5.88E-03	-3.16E-03	-9.33E-03	-1.16E-02	-9.09E-03	-1.20E-03
3	-5.75E-02	-8.69E-03	2.04E-03	-9.66E-05	-5.97E-03	-1.15E-02	-1.45E-02	-1.39E-02	-8.64E-03	1.97E-03
4	-5.95E-02	-1.26E-02	-2.21E-03	-3.76E-03	-8.55E-03	-1.27E-02	-1.43E-02	-1.21E-02	-5.19E-03	7.22E-03
5	-4.44E-02	-3.57E-03	3.15E-03	-1.88E-04	-5.72E-03	-9.97E-03	-1.13E-02	-8.39E-03	-6.16E-04	1.28E-02
6	-2.39E-02	1.01E-02	1.23E-02	6.20E-03	-8.89E-04	-5.96E-03	-7.50E-03	-4.67E-03	3.52E-03	1.73E-02
7	-7.02E-03	2.18E-02	2.08E-02	1.20E-02	3.12E-03	-3.11E-03	-5.39E-03	-2.97E-03	5.56E-03	1.94E-02
8	6.16E-04	2.75E-02	2.44E-02	1.39E-02	3.90E-03	-3.13E-03	-5.99E-03	-4.00E-03	4.19E-03	1.77E-02
9	-4.37E-03	2.40E-02	2.10E-02	1.03E-02	-7.51E-05	-7.44E-03	-1.06E-02	-9.03E-03	-1.27E-03	1.17E-02
10	-2.23E-02	1.06E-02	9.85E-03	3.24E-04	-9.43E-03	-1.66E-02	-1.98E-02	-1.84E-02	-1.10E-02	1.33E-03
Low	1	2	3	4	5	6	7	8	9	10
1	2.06E-02	2.88E-02	2.24E-02	1.24E-02	2.61E-03	-4.93E-03	-9.12E-03	-9.33E-03	-4.82E-03	4.97E-03
2	-3.29E-02	-1.73E-03	3.41E-03	2.69E-04	-4.85E-03	-8.93E-03	-1.04E-02	-8.24E-03	-1.60E-03	1.02E-02
3	-3.26E-02	2.86E-03	8.67E-03	5.32E-03	-1.71E-04	-4.64E-03	-6.43E-03	-4.58E-03	1.82E-03	1.34E-02
4	-2.21E-02	1.44E-02	1.85E-02	1.30E-02	5.46E-03	-9.42E-04	-4.51E-03	-4.34E-03	4.05E-04	1.03E-02
5	-2.29E-02	1.66E-02	2.05E-02	1.37E-02	4.45E-03	-3.83E-03	-9.46E-03	-1.13E-02	-8.83E-03	-1.39E-03
High	1	2	3	4	5	6	7	8	9	10
6	-2.59E-02	1.43E-02	1.93E-02	1.38E-02	5.84E-03	-1.28E-03	-5.87E-03	-7.05E-03	-3.90E-03	3.64E-03
7	-2.57E-02	1.10E-02	1.54E-02	9.78E-03	2.41E-03	-3.68E-03	-7.00E-03	-6.69E-03	-1.37E-03	8.04E-03
8	-1.86E-02	1.23E-02	1.38E-02	7.20E-03	-1.53E-04	-5.64E-03	-8.00E-03	-6.49E-03	2.27E-04	1.12E-02
9	-9.19E-03	1.46E-02	1.26E-02	4.46E-03	-3.29E-03	-8.50E-03	-1.02E-02	-7.73E-03	1.21E-04	1.24E-02
10	-1.30E-03	1.54E-02	9.79E-03	6.08E-05	-8.15E-03	-1.32E-02	-1.43E-02	-1.11E-02	-2.32E-03	1.11E-02

2 MeV Poly-Pb Exposure (Fractional Difference)

Full	1	2	3	4	5	6	7	8	9	10
1	1.47E-01	1.13E-01	8.54E-02	6.22E-02	4.29E-02	2.73E-02	1.52E-02	6.47E-03	1.22E-03	-5.71E-04
2	1.53E-02	2.14E-02	1.74E-02	1.04E-02	3.12E-03	-3.21E-03	-7.80E-03	-1.02E-02	-9.89E-03	-6.67E-03
3	-4.01E-02	-1.85E-02	-1.25E-02	-1.21E-02	-1.37E-02	-1.52E-02	-1.57E-02	-1.44E-02	-1.08E-02	-4.39E-03
4	-5.52E-02	-2.83E-02	-1.90E-02	-1.62E-02	-1.57E-02	-1.53E-02	-1.41E-02	-1.13E-02	-5.58E-03	2.45E-03
5	-4.93E-02	-2.14E-02	-1.25E-02	-1.01E-02	-9.40E-03	-9.22E-03	-7.43E-03	-4.21E-03	1.50E-03	1.07E-02
6	-3.42E-02	-7.54E-03	-5.18E-04	1.82E-04	-4.74E-04	-1.35E-03	-3.47E-04	2.31E-03	7.63E-03	1.66E-02
7	-1.82E-02	6.55E-03	1.11E-02	9.54E-03	6.96E-03	4.47E-03	4.11E-03	5.62E-03	9.95E-03	1.80E-02
8	-6.74E-03	1.61E-02	1.83E-02	1.45E-02	9.93E-03	5.63E-03	3.68E-03	3.72E-03	6.69E-03	1.35E-02
9	-3.00E-03	1.85E-02	1.88E-02	1.31E-02	6.67E-03	6.91E-04	-2.86E-03	-4.36E-03	-2.94E-03	2.24E-03
10	-8.05E-03	1.27E-02	1.16E-02	4.49E-03	-3.34E-03	-1.08E-02	-1.57E-02	-1.87E-02	-1.89E-02	-1.54E-02

Low	1	2	3	4	5	6	7	8	9	10
1	5.10E-02	3.57E-02	2.41E-02	1.49E-02	7.43E-03	1.74E-03	-2.31E-03	-4.68E-03	-5.18E-03	-3.80E-03
2	-2.45E-02	-1.19E-02	-7.92E-03	-6.87E-03	-6.82E-03	-6.72E-03	-6.01E-03	-4.29E-03	-1.19E-03	3.48E-03
3	-3.26E-02	-1.32E-02	-6.38E-03	-3.92E-03	-3.05E-03	-2.36E-03	-1.13E-03	1.05E-03	4.65E-03	9.83E-03
4	-1.75E-02	1.43E-03	5.81E-03	5.60E-03	3.95E-03	2.39E-03	1.62E-03	1.84E-03	4.11E-03	7.69E-03
5	-3.48E-03	1.33E-02	1.36E-02	9.25E-03	4.24E-03	-9.05E-04	-4.50E-03	-7.13E-03	-8.04E-03	-6.60E-03

High	1	2	3	4	5	6	7	8	9	10
6	-2.68E-03	1.12E-02	9.19E-03	3.69E-03	-1.14E-03	-4.87E-03	-5.92E-03	-4.89E-03	-1.08E-03	6.18E-03
7	-1.22E-02	6.13E-03	6.59E-03	2.58E-03	-1.41E-03	-4.71E-03	-5.61E-03	-4.65E-03	-1.09E-03	5.78E-03
8	-1.59E-02	5.60E-03	7.66E-03	4.41E-03	6.76E-04	-2.73E-03	-3.97E-03	-3.55E-03	-6.73E-04	5.36E-03
9	-1.74E-02	6.57E-03	9.71E-03	6.81E-03	2.97E-03	-8.36E-04	-2.71E-03	-3.09E-03	-1.19E-03	3.72E-03
10	-1.89E-02	7.01E-03	1.09E-02	8.17E-03	4.07E-03	-3.01E-04	-2.94E-03	-4.29E-03	-3.52E-03	1.05E-04

6 MeV Poly-Pb Exposure (Fractional Difference)

Full	1	2	3	4	5	6	7	8	9	10
1	1.31E-01	1.39E-01	1.40E-01	1.35E-01	1.25E-01	1.11E-01	9.45E-02	7.66E-02	5.77E-02	3.84E-02
2	3.61E-03	2.36E-02	3.38E-02	3.67E-02	3.41E-02	2.77E-02	1.85E-02	7.60E-03	-4.45E-03	-1.69E-02
3	-5.17E-02	-2.88E-02	-1.52E-02	-8.93E-03	-7.75E-03	-1.02E-02	-1.51E-02	-2.13E-02	-2.87E-02	-3.62E-02
4	-6.87E-02	-4.61E-02	-3.19E-02	-2.43E-02	-2.12E-02	-2.12E-02	-2.33E-02	-2.61E-02	-2.98E-02	-3.32E-02
5	-6.33E-02	-4.28E-02	-2.95E-02	-2.19E-02	-1.80E-02	-1.67E-02	-1.68E-02	-1.71E-02	-1.77E-02	-1.74E-02
6	-4.53E-02	-2.81E-02	-1.69E-02	-1.04E-02	-6.77E-03	-4.90E-03	-3.86E-03	-2.38E-03	-5.64E-04	2.79E-03
7	-2.21E-02	-9.41E-03	-1.38E-03	2.97E-03	5.34E-03	6.73E-03	8.45E-03	1.04E-02	1.37E-02	1.93E-02
8	3.17E-04	7.44E-03	1.13E-02	1.25E-02	1.27E-02	1.26E-02	1.35E-02	1.52E-02	1.88E-02	2.54E-02
9	1.59E-02	1.65E-02	1.51E-02	1.22E-02	9.02E-03	6.30E-03	5.09E-03	5.16E-03	7.64E-03	1.33E-02
10	2.12E-02	1.46E-02	7.33E-03	-5.09E-04	-7.83E-03	-1.41E-02	-1.90E-02	-2.14E-02	-2.16E-02	-1.85E-02

Low	1	2	3	4	5	6	7	8	9	10
1	2.61E-02	3.36E-02	3.71E-02	3.66E-02	3.27E-02	2.64E-02	1.83E-02	9.14E-03	-5.79E-04	-1.04E-02
2	-3.69E-02	-2.13E-02	-1.14E-02	-6.01E-03	-3.94E-03	-4.17E-03	-5.91E-03	-8.42E-03	-1.12E-02	-1.36E-02
3	-3.65E-02	-2.30E-02	-1.37E-02	-8.28E-03	-5.15E-03	-3.48E-03	-2.52E-03	-1.20E-03	2.43E-04	2.84E-03
4	-1.05E-02	-4.02E-03	7.03E-05	1.89E-03	2.70E-03	3.17E-03	3.87E-03	5.80E-03	8.71E-03	1.36E-02
5	1.74E-02	1.36E-02	9.44E-03	4.69E-03	2.53E-04	-3.48E-03	-6.11E-03	-6.77E-03	-5.83E-03	-2.31E-03

High	1	2	3	4	5	6	7	8	9	10
6	-1.55E-03	1.66E-03	4.24E-03	5.49E-03	5.92E-03	5.53E-03	4.30E-03	2.64E-03	-3.34E-04	-4.20E-03
7	-7.71E-03	-5.46E-03	-3.28E-03	-1.91E-03	-9.22E-04	-3.65E-04	1.55E-04	-2.90E-04	-1.31E-03	-2.95E-03
8	-5.27E-03	-4.64E-03	-3.52E-03	-2.69E-03	-1.79E-03	-9.21E-04	2.66E-04	8.33E-04	1.13E-03	1.11E-03
9	1.72E-03	-9.78E-05	-8.15E-04	-1.29E-03	-1.24E-03	-8.19E-04	2.82E-04	1.09E-03	1.94E-03	2.75E-03
10	1.09E-02	5.95E-03	2.74E-03	2.80E-04	-1.22E-03	-1.97E-03	-2.16E-03	-1.48E-03	-9.22E-04	-1.49E-04

10 MeV Poly-Pb Exposure (Fractional Difference)

Full	1	2	3	4	5	6	7	8	9	10
1	1.00E-01	1.26E-01	1.48E-01	1.61E-01	1.65E-01	1.60E-01	1.46E-01	1.24E-01	9.59E-02	6.07E-02
2	-1.99E-02	7.33E-03	2.90E-02	4.31E-02	4.93E-02	4.78E-02	3.89E-02	2.40E-02	3.19E-03	-2.31E-02
3	-7.18E-02	-4.69E-02	-2.66E-02	-1.24E-02	-4.75E-03	-3.29E-03	-7.92E-03	-1.72E-02	-3.13E-02	-4.99E-02
4	-8.70E-02	-6.57E-02	-4.75E-02	-3.38E-02	-2.53E-02	-2.14E-02	-2.23E-02	-2.65E-02	-3.42E-02	-4.52E-02
5	-7.97E-02	-6.30E-02	-4.76E-02	-3.52E-02	-2.65E-02	-2.10E-02	-1.88E-02	-1.86E-02	-2.03E-02	-2.37E-02
6	-5.82E-02	-4.72E-02	-3.56E-02	-2.55E-02	-1.75E-02	-1.15E-02	-7.33E-03	-3.63E-03	-3.29E-04	2.98E-03
7	-2.86E-02	-2.43E-02	-1.76E-02	-1.10E-02	-5.26E-03	-1.74E-04	4.28E-03	9.60E-03	1.60E-02	2.39E-02
8	4.47E-03	9.12E-04	1.32E-03	3.03E-03	4.93E-03	7.17E-03	9.72E-03	1.41E-02	2.05E-02	2.96E-02
9	3.71E-02	2.46E-02	1.74E-02	1.27E-02	8.98E-03	6.29E-03	4.47E-03	4.94E-03	7.82E-03	1.37E-02
10	6.63E-02	4.37E-02	2.79E-02	1.53E-02	4.40E-03	-5.10E-03	-1.35E-02	-1.97E-02	-2.36E-02	-2.50E-02

Low	1	2	3	4	5	6	7	8	9	10
1	9.54E-03	2.08E-02	3.37E-02	4.27E-02	4.66E-02	4.53E-02	3.88E-02	2.74E-02	1.12E-02	-9.54E-03
2	-4.77E-02	-3.56E-02	-2.31E-02	-1.29E-02	-6.27E-03	-3.18E-03	-3.90E-03	-7.25E-03	-1.35E-02	-2.24E-02
3	-4.07E-02	-3.45E-02	-2.61E-02	-1.83E-02	-1.21E-02	-7.56E-03	-4.84E-03	-2.68E-03	-1.18E-03	-4.86E-05
4	-3.45E-03	-7.22E-03	-6.53E-03	-4.44E-03	-2.26E-03	-8.70E-06	2.11E-03	5.48E-03	1.01E-02	1.66E-02
5	4.38E-02	2.67E-02	1.63E-02	8.98E-03	3.09E-03	-1.59E-03	-5.38E-03	-7.03E-03	-6.54E-03	-3.46E-03

High	1	2	3	4	5	6	7	8	9	10
6	-1.08E-02	-6.91E-03	-8.39E-04	4.69E-03	8.40E-03	1.01E-02	9.26E-03	6.76E-03	1.90E-03	-5.80E-03
7	-1.22E-02	-1.20E-02	-8.39E-03	-4.37E-03	-1.22E-03	8.54E-04	1.37E-03	1.20E-03	-2.99E-04	-3.59E-03
8	-4.34E-03	-8.20E-03	-7.71E-03	-5.82E-03	-3.90E-03	-2.21E-03	-1.20E-03	1.10E-05	8.59E-04	9.09E-04
9	1.00E-02	1.42E-03	-1.77E-03	-2.67E-03	-2.77E-03	-2.34E-03	-1.86E-03	-4.08E-04	1.47E-03	3.40E-03
10	2.87E-02	1.47E-02	7.19E-03	2.76E-03	-1.83E-04	-1.99E-03	-3.17E-03	-2.81E-03	-1.47E-03	5.37E-04

Lead Followed by Polyethylene

65 keV Pb-Poly Exposure (Fractional Difference)

Full	1	2	3	4	5	6	7	8	9	10
1	-1.04E+00	-1.92E-01	1.72E-02	6.02E-02	5.95E-02	5.08E-02	4.35E-02	3.64E-02	2.18E-02	-1.33E-02
2	-9.72E-01	-2.02E-01	-1.31E-02	2.56E-02	2.63E-02	2.13E-02	1.94E-02	1.91E-02	1.22E-02	-1.52E-02
3	-8.72E-01	-1.87E-01	-2.49E-02	5.39E-03	4.43E-03	1.10E-03	2.82E-03	7.81E-03	7.42E-03	-1.32E-02
4	-7.43E-01	-1.52E-01	-2.19E-02	-3.60E-03	-8.62E-03	-1.22E-02	-8.32E-03	7.00E-04	5.80E-03	-8.92E-03
5	-5.90E-01	-9.95E-02	-6.76E-03	-3.42E-03	-1.46E-02	-2.00E-02	-1.53E-02	-3.48E-03	6.00E-03	-3.71E-03
6	-4.16E-01	-3.34E-02	1.86E-02	4.40E-03	-1.47E-02	-2.34E-02	-1.92E-02	-5.74E-03	6.99E-03	1.27E-03
7	-2.25E-01	4.46E-02	5.23E-02	1.84E-02	-1.02E-02	-2.34E-02	-2.08E-02	-7.02E-03	7.69E-03	4.81E-03
8	-1.87E-02	1.32E-01	9.30E-02	3.77E-02	-1.82E-03	-2.08E-02	-2.10E-02	-8.05E-03	7.32E-03	5.99E-03
9	1.99E-01	2.28E-01	1.39E-01	6.09E-02	9.37E-03	-1.64E-02	-2.05E-02	-9.59E-03	5.04E-03	3.85E-03
10	4.26E-01	3.31E-01	1.90E-01	8.73E-02	2.27E-02	-1.08E-02	-1.99E-02	-1.22E-02	2.55E-04	-2.25E-03

Low	1	2	3	4	5	6	7	8	9	10
1	-7.28E-01	-1.05E-01	2.43E-02	3.65E-02	2.44E-02	1.37E-02	1.04E-02	1.23E-02	1.09E-02	-8.56E-03
2	-6.18E-01	-8.71E-02	1.37E-02	1.67E-02	2.54E-03	-6.73E-03	-6.32E-03	1.17E-03	6.89E-03	-4.84E-03
3	-4.41E-01	-2.68E-02	3.15E-02	1.72E-02	-4.08E-03	-1.57E-02	-1.47E-02	-4.38E-03	5.94E-03	-3.26E-04
4	-2.07E-01	6.75E-02	7.20E-02	3.38E-02	1.04E-03	-1.61E-02	-1.73E-02	-6.85E-03	5.43E-03	2.16E-03
5	7.22E-02	1.89E-01	1.31E-01	6.32E-02	1.52E-02	-1.03E-02	-1.62E-02	-8.15E-03	3.34E-03	3.68E-04

High	1	2	3	4	5	6	7	8	9	10
6	-6.69E-01	-1.03E-01	1.33E-02	2.27E-02	1.12E-02	2.27E-03	1.47E-03	6.49E-03	8.92E-03	-5.85E-03
7	-5.24E-01	-5.28E-02	2.82E-02	2.33E-02	5.69E-03	-5.32E-03	-5.83E-03	1.23E-03	7.08E-03	-3.64E-03
8	-3.69E-01	5.40E-03	4.95E-02	2.89E-02	4.12E-03	-9.85E-03	-1.09E-02	-2.52E-03	6.00E-03	-1.30E-03
9	-2.04E-01	7.07E-02	7.62E-02	3.86E-02	5.74E-03	-1.20E-02	-1.43E-02	-5.40E-03	5.03E-03	4.19E-04
10	-3.12E-02	1.42E-01	1.07E-01	5.17E-02	9.99E-03	-1.22E-02	-1.65E-02	-7.85E-03	3.67E-03	9.51E-04

100 keV Pb-Poly Exposure (Fractional Difference)

Full	1	2	3	4	5	6	7	8	9	10
1	3.26E-01	1.59E-01	6.95E-02	2.74E-02	7.64E-03	-4.81E-03	-1.85E-02	-3.85E-02	-6.70E-02	-1.05E-01
2	1.39E-01	4.24E-02	-5.21E-03	-1.66E-02	-1.18E-02	-3.83E-03	-6.59E-04	-7.10E-03	-2.56E-02	-5.66E-02
3	2.48E-02	-3.14E-02	-5.17E-02	-4.15E-02	-1.81E-02	6.37E-03	2.38E-02	2.91E-02	1.96E-02	-5.31E-03
4	-4.26E-02	-7.63E-02	-7.94E-02	-5.49E-02	-1.84E-02	1.81E-02	4.63E-02	6.09E-02	5.86E-02	3.88E-02
5	-7.53E-02	-9.84E-02	-9.28E-02	-6.06E-02	-1.70E-02	2.61E-02	6.03E-02	8.00E-02	8.18E-02	6.49E-02
6	-7.84E-02	-1.00E-01	-9.32E-02	-5.99E-02	-1.55E-02	2.79E-02	6.22E-02	8.15E-02	8.27E-02	6.51E-02
7	-5.30E-02	-8.18E-02	-8.01E-02	-5.20E-02	-1.33E-02	2.40E-02	5.18E-02	6.48E-02	6.02E-02	3.76E-02
8	2.43E-03	-4.17E-02	-5.23E-02	-3.55E-02	-8.47E-03	1.67E-02	3.22E-02	3.33E-02	1.81E-02	-1.33E-02
9	9.15E-02	2.24E-02	-7.81E-03	-8.64E-03	1.00E-03	8.72E-03	7.15E-03	-7.61E-03	-3.68E-02	-7.97E-02
10	2.19E-01	1.13E-01	5.45E-02	2.94E-02	1.63E-02	2.15E-03	-2.00E-02	-5.33E-02	-9.83E-02	-1.54E-01

Low	1	2	3	4	5	6	7	8	9	10
1	6.36E-02	4.90E-02	3.15E-02	2.12E-02	1.35E-02	5.36E-03	-4.20E-03	-1.53E-02	-2.76E-02	-4.07E-02
2	-3.77E-02	-1.94E-02	-1.49E-02	-7.63E-03	-4.05E-04	4.39E-03	5.97E-03	4.42E-03	2.09E-04	-6.05E-03
3	-5.69E-02	-3.33E-02	-2.48E-02	-1.31E-02	-8.23E-04	9.39E-03	1.65E-02	2.04E-02	2.13E-02	1.98E-02
4	-1.89E-02	-1.08E-02	-1.38E-02	-9.44E-03	-1.47E-03	6.71E-03	1.35E-02	1.83E-02	2.10E-02	2.19E-02
5	6.21E-02	3.39E-02	4.74E-03	-9.27E-03	-1.44E-02	-1.54E-02	-1.49E-02	-1.39E-02	-1.32E-02	-1.29E-02

High	1	2	3	4	5	6	7	8	9	10
6	-5.52E-02	9.05E-04	6.03E-02	1.23E-01	1.83E-01	2.39E-01	2.87E-01	3.28E-01	3.61E-01	3.87E-01
7	-1.15E-01	-3.38E-02	4.62E-02	1.25E-01	1.99E-01	2.66E-01	3.24E-01	3.73E-01	4.14E-01	4.46E-01
8	-1.49E-01	-5.06E-02	4.23E-02	1.30E-01	2.09E-01	2.78E-01	3.36E-01	3.85E-01	4.24E-01	4.54E-01
9	-1.54E-01	-4.29E-02	5.56E-02	1.43E-01	2.18E-01	2.80E-01	3.30E-01	3.69E-01	3.98E-01	4.19E-01
10	-1.20E-01	-3.72E-03	9.24E-02	1.71E-01	2.32E-01	2.78E-01	3.11E-01	3.32E-01	3.44E-01	3.49E-01

500 keV Poly-Pb-Poly Exposure (Fractional Difference)

Full	1	2	3	4	5	6	7	8	9	10
1	-9.00E-02	4.51E-02	8.94E-02	9.73E-02	9.01E-02	7.64E-02	5.94E-02	3.96E-02	1.63E-02	-1.15E-02
2	-1.51E-01	-2.31E-02	2.37E-02	3.78E-02	3.83E-02	3.30E-02	2.44E-02	1.28E-02	-2.78E-03	-2.36E-02
3	-1.67E-01	-5.45E-02	-1.13E-02	4.31E-03	8.78E-03	8.63E-03	5.88E-03	3.71E-04	-9.22E-03	-2.46E-02
4	-1.57E-01	-6.33E-02	-2.70E-02	-1.29E-02	-6.93E-03	-3.90E-03	-2.43E-03	-3.19E-03	-7.87E-03	-1.87E-02
5	-1.28E-01	-5.64E-02	-2.97E-02	-1.92E-02	-1.36E-02	-8.94E-03	-4.56E-03	-1.63E-03	-2.34E-03	-9.23E-03
6	-8.59E-02	-3.84E-02	-2.35E-02	-1.84E-02	-1.46E-02	-9.64E-03	-3.51E-03	2.09E-03	4.56E-03	8.72E-04
7	-3.40E-02	-1.28E-02	-1.12E-02	-1.30E-02	-1.25E-02	-8.51E-03	-1.81E-03	5.39E-03	1.01E-02	8.77E-03
8	2.40E-02	1.76E-02	4.36E-03	-5.66E-03	-9.68E-03	-7.83E-03	-1.77E-03	5.84E-03	1.16E-02	1.16E-02
9	8.52E-02	5.01E-02	2.11E-02	1.74E-03	-7.92E-03	-9.45E-03	-5.30E-03	1.44E-03	7.08E-03	7.32E-03
10	1.47E-01	8.26E-02	3.70E-02	7.51E-03	-8.80E-03	-1.49E-02	-1.39E-02	-9.34E-03	-5.27E-03	-5.95E-03

Low	1	2	3	4	5	6	7	8	9	10
1	-8.64E-02	1.50E-03	2.88E-02	3.38E-02	3.08E-02	2.56E-02	1.96E-02	1.21E-02	1.71E-03	-1.37E-02
2	-1.07E-01	-3.42E-02	-9.85E-03	-2.78E-03	-8.23E-04	3.60E-04	1.61E-03	1.96E-03	-6.09E-04	-8.63E-03
3	-7.14E-02	-2.63E-02	-1.45E-02	-1.24E-02	-1.12E-02	-8.35E-03	-3.74E-03	1.05E-03	3.49E-03	4.66E-04
4	-3.20E-05	8.30E-03	1.23E-03	-6.60E-03	-1.05E-02	-9.57E-03	-4.90E-03	1.30E-03	6.05E-03	5.69E-03
5	9.32E-02	5.88E-02	2.83E-02	6.70E-03	-5.56E-03	-9.74E-03	-8.09E-03	-3.44E-03	6.86E-04	4.69E-04

High	1	2	3	4	5	6	7	8	9	10
6	-8.56E-02	-1.68E-02	4.90E-03	9.84E-03	9.70E-03	8.73E-03	7.78E-03	6.00E-03	1.66E-03	-7.33E-03
7	-6.16E-02	-1.20E-02	1.04E-03	2.33E-03	1.31E-03	1.14E-03	2.08E-03	2.88E-03	1.49E-03	-4.54E-03
8	-3.01E-02	-5.32E-04	2.68E-03	-6.34E-04	-3.38E-03	-3.52E-03	-1.38E-03	1.39E-03	2.44E-03	-1.13E-03
9	7.13E-03	1.56E-02	8.17E-03	-5.71E-04	-5.82E-03	-6.63E-03	-3.97E-03	1.43E-04	3.06E-03	1.53E-03
10	4.82E-02	3.50E-02	1.62E-02	1.26E-03	-7.20E-03	-9.40E-03	-6.92E-03	-2.14E-03	1.93E-03	1.96E-03

1 MeV Pb-Poly Exposure (Fractional Difference)

Full	1	2	3	4	5	6	7	8	9	10
1	1.14E+00	5.88E-01	2.85E-01	1.05E-01	-4.58E-03	-6.47E-02	-8.22E-02	-2.04E-02	-1.12E-01	3.67E-02
2	7.90E-01	3.64E-01	1.26E-01	-1.70E-02	-1.02E-01	-1.47E-01	-1.58E-01	-1.35E-01	-6.54E-02	7.28E-02
3	6.03E-01	2.45E-01	4.44E-02	-7.33E-02	-1.39E-01	-1.67E-01	-1.58E-01	-1.05E-01	5.21E-02	1.07E-01
4	5.02E-01	1.85E-01	8.18E-03	-9.19E-02	-1.43E-01	-1.55E-01	-1.30E-01	-6.03E-02	6.35E-02	-5.58E-03
5	4.51E-01	1.59E-01	-1.22E-03	-8.89E-02	-1.29E-01	-1.31E-01	-9.61E-02	-2.44E-02	6.85E-02	3.79E-02
6	4.31E-01	1.55E-01	5.22E-03	-7.41E-02	-1.07E-01	-1.03E-01	-6.56E-02	-9.12E-04	6.44E-02	2.96E-02
7	4.30E-01	1.64E-01	2.05E-02	-5.38E-02	-8.25E-02	-7.64E-02	-4.18E-02	1.13E-02	5.34E-02	1.27E-02
8	4.41E-01	1.80E-01	4.00E-02	-3.18E-02	-5.94E-02	-5.45E-02	-2.56E-02	1.45E-02	3.76E-02	-8.09E-03
9	4.59E-01	1.99E-01	6.09E-02	-1.06E-02	-3.92E-02	-3.78E-02	-1.64E-02	1.08E-02	1.85E-02	-3.09E-02
10	4.80E-01	2.20E-01	8.11E-02	8.33E-03	-2.29E-02	-2.64E-02	-1.34E-02	1.73E-03	-2.87E-03	-5.50E-02

Low	1	2	3	4	5	6	7	8	9	10
1	-7.47E-03	2.91E-02	3.79E-02	3.60E-02	3.00E-02	2.22E-02	1.35E-02	4.29E-03	-5.53E-03	-1.60E-02
2	-6.21E-02	-2.34E-02	-7.84E-03	-1.20E-03	1.49E-03	2.14E-03	1.43E-03	-4.37E-04	-3.57E-03	-8.02E-03
3	-4.98E-02	-2.74E-02	-1.73E-02	-1.12E-02	-6.69E-03	-2.95E-03	6.79E-05	2.12E-03	2.89E-03	2.20E-03
4	-2.21E-03	-5.61E-03	-8.03E-03	-8.10E-03	-6.22E-03	-3.17E-03	3.38E-04	3.61E-03	5.99E-03	7.12E-03
5	6.19E-02	2.73E-02	8.02E-03	-1.87E-03	-5.90E-03	-6.39E-03	-4.95E-03	-2.75E-03	-7.65E-04	3.91E-04

High	1	2	3	4	5	6	7	8	9	10
6	-2.26E-02	-6.33E-04	6.61E-03	8.53E-03	8.26E-03	6.86E-03	4.67E-03	1.80E-03	-1.84E-03	-6.16E-03
7	-2.03E-02	-5.19E-03	-3.25E-04	1.35E-03	1.93E-03	1.98E-03	1.55E-03	5.87E-04	-1.09E-03	-3.48E-03
8	-1.02E-02	-3.47E-03	-2.16E-03	-1.71E-03	-1.09E-03	-3.00E-04	4.20E-04	8.47E-04	6.64E-04	-1.97E-04
9	4.88E-03	2.10E-03	-1.08E-03	-2.66E-03	-2.69E-03	-1.74E-03	-3.67E-04	9.81E-04	1.88E-03	2.18E-03
10	2.26E-02	9.36E-03	8.84E-04	-3.38E-03	-4.69E-03	-4.14E-03	-2.62E-03	-7.89E-04	8.05E-04	1.92E-03

2 MeV Pb-Poly Exposure (Fractional Difference)

Full	1	2	3	4	5	6	7	8	9	10
1	1.17E-01	1.14E-01	9.96E-02	8.06E-02	6.01E-02	3.98E-02	2.08E-02	3.44E-03	-1.21E-02	-2.57E-02
2	3.03E-03	2.78E-02	3.51E-02	3.28E-02	2.55E-02	1.56E-02	4.94E-03	-5.67E-03	-1.56E-02	-2.45E-02
3	-4.92E-02	-1.68E-02	-4.16E-04	6.01E-03	6.32E-03	3.07E-03	-2.02E-03	-7.83E-03	-1.36E-02	-1.90E-02
4	-6.69E-02	-3.58E-02	-1.69E-02	-6.59E-03	-2.12E-03	-1.37E-03	-2.79E-03	-5.31E-03	-8.15E-03	-1.08E-02
5	-6.27E-02	-3.83E-02	-2.09E-02	-9.80E-03	-3.54E-03	-6.65E-04	1.06E-04	-2.48E-04	-1.02E-03	-1.72E-03
6	-4.47E-02	-3.05E-02	-1.73E-02	-7.55E-03	-1.29E-03	2.30E-03	4.18E-03	5.09E-03	5.66E-03	6.34E-03
7	-1.91E-02	-1.73E-02	-1.01E-02	-3.34E-03	1.68E-03	4.99E-03	7.12E-03	8.64E-03	9.99E-03	1.16E-02
8	8.62E-03	-3.28E-03	-3.31E-03	-4.71E-04	2.47E-03	4.79E-03	6.60E-03	8.22E-03	9.95E-03	1.21E-02
9	3.38E-02	7.79E-03	7.28E-05	-1.49E-03	-1.14E-03	-2.26E-04	8.99E-04	2.29E-03	4.11E-03	6.52E-03
10	5.21E-02	1.27E-02	-2.63E-03	-8.69E-03	-1.10E-02	-1.17E-02	-1.14E-02	-1.04E-02	-8.68E-03	-6.15E-03

Low	1	2	3	4	5	6	7	8	9	10
1	2.38E-02	3.13E-02	3.11E-02	2.66E-02	1.99E-02	1.24E-02	4.89E-03	-2.22E-03	-8.69E-03	-1.44E-02
2	-3.76E-02	-1.83E-02	-6.73E-03	-6.56E-04	1.76E-03	1.90E-03	8.08E-04	-8.55E-04	-2.65E-03	-4.30E-03
3	-3.41E-02	-2.45E-02	-1.48E-02	-7.49E-03	-2.67E-03	2.61E-04	1.97E-03	2.99E-03	3.68E-03	4.33E-03
4	1.74E-04	-9.33E-03	-8.47E-03	-5.32E-03	-2.25E-03	2.18E-04	2.17E-03	3.77E-03	5.26E-03	6.81E-03
5	4.42E-02	1.21E-02	7.56E-04	-3.09E-03	-4.16E-03	-4.19E-03	-3.75E-03	-3.00E-03	-1.95E-03	-5.71E-04

High	1	2	3	4	5	6	7	8	9	10
6	-6.27E-03	8.86E-04	6.43E-03	8.69E-03	8.11E-03	5.63E-03	2.24E-03	-1.33E-03	-4.48E-03	-6.84E-03
7	-9.73E-03	-5.62E-03	-4.86E-04	2.62E-03	3.49E-03	2.71E-03	1.10E-03	-6.63E-04	-2.07E-03	-2.70E-03
8	-5.25E-03	-6.08E-03	-2.87E-03	-1.56E-04	1.16E-03	1.27E-03	8.08E-04	3.12E-04	2.43E-04	9.71E-04
9	4.18E-03	-3.05E-03	-2.85E-03	-1.40E-03	-4.16E-04	3.54E-06	1.74E-04	5.31E-04	1.45E-03	3.24E-03
10	1.56E-02	9.51E-04	-2.66E-03	-3.13E-03	-2.91E-03	-2.63E-03	-2.18E-03	-1.26E-03	3.76E-04	3.01E-03

6 MeV Pb-Poly Exposure (Fractional Difference)

Full	1	2	3	4	5	6	7	8	9	10
1	8.41E-03	4.46E-02	4.23E-02	2.94E-02	1.56E-02	4.72E-03	-1.74E-03	-3.08E-03	9.69E-04	1.07E-02
2	-3.94E-02	9.00E-03	1.59E-02	9.35E-03	9.29E-05	-7.37E-03	-1.12E-02	-1.04E-02	-4.58E-03	6.68E-03
3	-4.86E-02	-2.91E-03	5.65E-03	1.03E-03	-6.50E-03	-1.25E-02	-1.51E-02	-1.33E-02	-6.67E-03	5.33E-03
4	-3.78E-02	-6.53E-04	5.80E-03	7.00E-04	-6.84E-03	-1.27E-02	-1.51E-02	-1.32E-02	-6.34E-03	5.79E-03
5	-2.04E-02	7.86E-03	1.13E-02	4.84E-03	-3.46E-03	-9.86E-03	-1.27E-02	-1.10E-02	-4.52E-03	7.27E-03
6	-5.46E-03	1.64E-02	1.78E-02	1.03E-02	1.24E-03	-5.79E-03	-9.19E-03	-8.12E-03	-2.19E-03	8.98E-03
7	1.54E-03	2.08E-02	2.20E-02	1.45E-02	5.29E-03	-2.08E-03	-5.93E-03	-5.43E-03	-1.66E-04	1.02E-02
8	-2.09E-03	1.82E-02	2.16E-02	1.56E-02	7.17E-03	4.76E-05	-3.95E-03	-3.84E-03	8.48E-04	1.05E-02
9	-1.70E-02	7.51E-03	1.52E-02	1.23E-02	5.66E-03	-4.84E-04	-4.11E-03	-4.06E-03	2.38E-04	9.27E-03
10	-4.22E-02	-1.13E-02	2.40E-03	3.88E-03	1.99E-04	-4.20E-03	-6.90E-03	-6.52E-03	-2.33E-03	6.23E-03

Low	1	2	3	4	5	6	7	8	9	10
1	3.42E-02	1.57E-02	6.43E-03	1.29E-03	-1.61E-03	-2.97E-03	-3.21E-03	-2.46E-03	-8.76E-04	1.50E-03
2	-8.97E-03	-5.62E-03	-4.83E-03	-4.74E-03	-4.57E-03	-3.95E-03	-2.81E-03	-1.05E-03	1.30E-03	4.29E-03
3	-1.69E-02	-5.78E-03	-1.96E-03	-1.14E-03	-1.13E-03	-1.03E-03	-5.11E-04	6.26E-04	2.38E-03	4.82E-03
4	-1.29E-02	1.34E-03	5.52E-03	5.21E-03	3.53E-03	1.84E-03	6.36E-04	1.88E-04	5.16E-04	1.67E-03
5	-1.14E-02	5.54E-03	1.02E-02	8.81E-03	5.32E-03	1.60E-03	-1.61E-03	-3.96E-03	-5.39E-03	-5.86E-03

High	1	2	3	4	5	6	7	8	9	10
6	-2.43E-02	1.03E-02	1.65E-02	1.06E-02	1.95E-03	-5.09E-03	-8.57E-03	-7.47E-03	-1.28E-03	1.04E-02
7	-1.38E-02	1.13E-02	1.49E-02	8.42E-03	-3.33E-04	-7.37E-03	-1.09E-02	-9.83E-03	-3.84E-03	7.57E-03
8	-8.40E-03	1.17E-02	1.46E-02	8.34E-03	-1.29E-04	-7.02E-03	-1.05E-02	-9.64E-03	-3.91E-03	7.15E-03
9	-9.83E-03	9.13E-03	1.34E-02	8.55E-03	1.02E-03	-5.34E-03	-8.63E-03	-7.79E-03	-2.28E-03	8.39E-03
10	-1.86E-02	2.51E-03	1.01E-02	7.84E-03	2.08E-03	-3.24E-03	-5.99E-03	-4.98E-03	4.45E-04	1.08E-02

10 MeV Pb-Poly Exposure (Fractional Difference)

Full	1	2	3	4	5	6	7	8	9	10
1	-3.21E-02	8.69E-02	7.24E-02	4.03E-02	1.17E-02	-8.54E-03	-1.99E-02	-2.24E-02	-1.63E-02	-1.43E-03
2	-5.98E-02	6.26E-02	5.59E-02	2.90E-02	4.02E-03	-1.37E-02	-2.31E-02	-2.40E-02	-1.65E-02	-2.91E-04
3	-6.49E-02	4.73E-02	4.46E-02	2.12E-02	-1.01E-03	-1.67E-02	-2.44E-02	-2.40E-02	-1.52E-02	2.06E-03
4	-5.55E-02	3.84E-02	3.70E-02	1.63E-02	-3.81E-03	-1.78E-02	-2.42E-02	-2.25E-02	-1.28E-02	5.51E-03
5	-3.84E-02	3.31E-02	3.19E-02	1.33E-02	-4.94E-03	-1.74E-02	-2.26E-02	-1.99E-02	-9.25E-03	9.92E-03
6	-1.94E-02	2.92E-02	2.78E-02	1.14E-02	-4.98E-03	-1.60E-02	-2.00E-02	-1.64E-02	-4.86E-03	1.51E-02
7	-3.63E-03	2.40E-02	2.34E-02	9.57E-03	-4.63E-03	-1.41E-02	-1.69E-02	-1.23E-02	9.38E-05	2.09E-02
8	4.84E-03	1.57E-02	1.74E-02	7.13E-03	-4.39E-03	-1.19E-02	-1.34E-02	-7.74E-03	5.53E-03	2.71E-02
9	2.93E-03	2.64E-03	8.59E-03	3.10E-03	-4.97E-03	-1.02E-02	-9.97E-03	-3.11E-03	1.11E-02	3.35E-02
10	-1.12E-02	-1.66E-02	-4.12E-03	-3.39E-03	-7.08E-03	-9.32E-03	-7.09E-03	1.22E-03	1.66E-02	3.98E-02

Low	1	2	3	4	5	6	7	8	9	10
1	3.22E-02	1.46E-02	1.83E-03	-5.71E-03	-9.33E-03	-9.86E-03	-7.77E-03	-3.29E-03	3.37E-03	1.22E-02
2	-7.32E-03	4.29E-03	1.77E-04	-4.94E-03	-8.18E-03	-9.07E-03	-7.62E-03	-3.85E-03	2.07E-03	1.01E-02
3	-2.23E-02	9.38E-03	1.01E-02	4.53E-03	-7.59E-04	-4.08E-03	-5.03E-03	-3.55E-03	2.57E-04	6.32E-03
4	-3.48E-02	1.57E-02	2.17E-02	1.56E-02	7.81E-03	1.43E-03	-2.63E-03	-4.14E-03	-3.16E-03	2.21E-04
5	-5.75E-02	1.32E-02	2.73E-02	2.26E-02	1.34E-02	4.44E-03	-2.51E-03	-6.97E-03	-8.90E-03	-8.36E-03

High	1	2	3	4	5	6	7	8	9	10
6	-3.38E-02	3.26E-02	3.75E-02	2.29E-02	6.41E-03	-5.89E-03	-1.20E-02	-1.10E-02	-2.89E-03	1.29E-02
7	-1.45E-02	1.99E-02	2.42E-02	1.24E-02	-1.66E-03	-1.21E-02	-1.69E-02	-1.50E-02	-6.20E-03	1.00E-02
8	-1.67E-03	1.10E-02	1.57E-02	6.69E-03	-5.08E-03	-1.40E-02	-1.76E-02	-1.50E-02	-5.66E-03	1.09E-02
9	3.05E-03	2.74E-03	9.85E-03	4.26E-03	-5.01E-03	-1.22E-02	-1.48E-02	-1.15E-02	-1.73E-03	1.51E-02
10	-7.72E-04	-6.82E-03	4.77E-03	3.70E-03	-2.49E-03	-7.79E-03	-9.17E-03	-5.12E-03	5.17E-03	2.24E-02

Stainless Steel Followed by Lead

65 keV SS-Pb Exposure (Fractional Difference)

Full	1	2	3	4	5	6	7	8	9	10
1	1.42E-02	1.73E-02	1.54E-02	1.15E-02	6.85E-03	2.27E-03	-1.82E-03	-4.52E-03	-6.31E-03	-7.44E-03
2	-3.06E-03	6.26E-03	7.85E-03	6.27E-03	3.34E-03	1.65E-04	-2.69E-03	-4.22E-03	-5.08E-03	-5.22E-03
3	-1.18E-02	2.76E-04	3.61E-03	3.33E-03	1.47E-03	-7.48E-04	-2.61E-03	-3.32E-03	-3.35E-03	-2.61E-03
4	-1.53E-02	-2.37E-03	1.67E-03	2.02E-03	7.62E-04	-7.30E-04	-1.76E-03	-1.92E-03	-1.46E-03	1.36E-04
5	-1.55E-02	-2.74E-03	1.28E-03	1.72E-03	7.75E-04	-2.58E-04	-7.67E-04	-4.73E-04	4.48E-04	2.45E-03
6	-1.34E-02	-1.56E-03	1.84E-03	2.05E-03	1.20E-03	4.34E-04	-3.97E-05	4.47E-04	1.83E-03	4.61E-03
7	-9.54E-03	5.62E-04	2.94E-03	2.50E-03	1.35E-03	5.57E-04	4.16E-04	1.09E-03	2.92E-03	5.70E-03
8	-4.82E-03	2.89E-03	3.69E-03	2.35E-03	8.71E-04	-5.91E-05	-3.56E-04	3.65E-04	2.02E-03	5.72E-03
9	2.07E-04	4.83E-03	3.71E-03	1.29E-03	-7.97E-04	-2.22E-03	-2.59E-03	-1.71E-03	7.04E-04	4.55E-03
10	4.58E-03	5.45E-03	2.12E-03	-1.64E-03	-4.48E-03	-6.20E-03	-6.72E-03	-5.71E-03	-2.88E-03	1.55E-03

Low	1	2	3	4	5	6	7	8	9	10
1	5.37E-03	7.58E-03	6.23E-03	3.75E-03	1.01E-03	-1.35E-03	-3.03E-03	-3.21E-03	-2.40E-03	-8.58E-04
2	-8.30E-03	-3.95E-04	1.31E-03	7.48E-04	-5.92E-04	-1.83E-03	-2.54E-03	-1.79E-03	-2.73E-04	2.05E-03
3	-1.02E-02	-8.66E-04	1.48E-03	1.27E-03	1.72E-04	-8.54E-04	-1.24E-03	-2.73E-04	1.51E-03	4.16E-03
4	-6.64E-03	1.94E-03	3.53E-03	2.67E-03	1.04E-03	-2.88E-04	-7.90E-04	-1.57E-04	1.26E-03	3.96E-03
5	-2.15E-03	4.58E-03	4.64E-03	2.53E-03	-3.73E-05	-2.06E-03	-3.14E-03	-3.12E-03	-2.28E-03	-2.06E-04

High	1	2	3	4	5	6	7	8	9	10
6	-8.52E-04	4.15E-03	3.55E-03	1.56E-03	-3.86E-04	-1.62E-03	-2.25E-03	-1.84E-03	-6.20E-04	1.77E-03
7	-4.27E-03	1.72E-03	2.00E-03	6.17E-04	-8.37E-04	-1.67E-03	-1.83E-03	-1.32E-03	6.61E-05	2.00E-03
8	-5.21E-03	1.35E-03	2.01E-03	9.53E-04	-1.41E-04	-8.21E-04	-1.15E-03	-8.57E-04	-1.14E-04	2.11E-03
9	-4.83E-03	1.96E-03	2.78E-03	1.86E-03	7.70E-04	-2.32E-04	-7.96E-04	-7.55E-04	1.11E-04	1.67E-03
10	-4.34E-03	2.46E-03	3.27E-03	2.23E-03	9.14E-04	-3.34E-04	-1.34E-03	-1.76E-03	-1.26E-03	-1.09E-04

100 keV SS-Pb Exposure (Fractional Difference)

Full	1	2	3	4	5	6	7	8	9	10
1	1.55E-01	1.24E-01	1.11E-01	9.89E-02	7.97E-02	5.28E-02	2.18E-02	-7.06E-03	-2.54E-02	-2.28E-02
2	3.72E-02	2.90E-02	3.13E-02	2.98E-02	2.00E-02	2.26E-03	-1.91E-02	-3.70E-02	-4.21E-02	-2.25E-02
3	-2.91E-02	-2.43E-02	-1.21E-02	-5.84E-03	-8.11E-03	-1.83E-02	-3.16E-02	-4.01E-02	-3.35E-02	1.85E-03
4	-6.49E-02	-5.15E-02	-3.24E-02	-2.01E-02	-1.67E-02	-2.14E-02	-2.86E-02	-2.98E-02	-1.40E-02	3.44E-02
5	-7.92E-02	-6.01E-02	-3.61E-02	-1.96E-02	-1.27E-02	-1.40E-02	-1.76E-02	-1.48E-02	6.46E-03	6.29E-02
6	-7.77E-02	-5.48E-02	-2.79E-02	-9.27E-03	-1.10E-03	-1.80E-03	-5.20E-03	-2.03E-03	2.00E-02	7.77E-02
7	-6.41E-02	-3.92E-02	-1.12E-02	7.27E-03	1.41E-02	1.10E-02	4.43E-03	3.68E-03	2.09E-02	7.25E-02
8	-4.15E-02	-1.66E-02	1.05E-02	2.65E-02	2.93E-02	2.08E-02	7.46E-03	-1.35E-03	5.86E-03	4.39E-02
9	-1.30E-02	1.01E-02	3.42E-02	4.53E-02	4.13E-02	2.44E-02	1.07E-03	-1.94E-02	-2.64E-02	-7.12E-03
10	1.88E-02	3.82E-02	5.71E-02	6.09E-02	4.77E-02	1.98E-02	-1.59E-02	-5.04E-02	-7.40E-02	-7.62E-02

Low	1	2	3	4	5	6	7	8	9	10
1	7.48E-02	4.16E-02	3.19E-02	2.74E-02	2.12E-02	1.11E-02	-1.42E-03	-1.28E-02	-1.76E-02	-9.35E-03
2	-1.04E-02	-2.19E-02	-1.76E-02	-1.15E-02	-8.83E-03	-1.04E-02	-1.40E-02	-1.51E-02	-7.24E-03	1.71E-02
3	-3.88E-02	-3.86E-02	-2.61E-02	-1.44E-02	-7.28E-03	-5.43E-03	-6.07E-03	-4.05E-03	7.43E-03	3.66E-02
4	-3.15E-02	-2.52E-02	-8.93E-03	4.11E-03	1.04E-02	9.44E-03	4.29E-03	3.89E-04	4.38E-03	2.40E-02
5	1.24E-04	8.15E-03	2.39E-02	3.35E-02	3.32E-02	2.27E-02	5.32E-03	-1.36E-02	-2.78E-02	-3.04E-02

High	1	2	3	4	5	6	7	8	9	10
6	1.17E-01	5.64E-02	2.43E-02	4.73E-05	-2.07E-02	-3.87E-02	-5.20E-02	-5.84E-02	-5.62E-02	-4.62E-02
7	8.87E-02	3.63E-02	1.05E-02	-8.73E-03	-2.54E-02	-4.02E-02	-5.11E-02	-5.57E-02	-5.26E-02	-4.25E-02
8	7.28E-02	2.70E-02	6.17E-03	-9.18E-03	-2.31E-02	-3.62E-02	-4.65E-02	-5.18E-02	-5.06E-02	-4.41E-02
9	6.67E-02	2.60E-02	9.20E-03	-3.42E-03	-1.59E-02	-2.89E-02	-4.06E-02	-4.89E-02	-5.27E-02	-5.32E-02
10	6.84E-02	3.18E-02	1.79E-02	6.94E-03	-5.47E-03	-2.01E-02	-3.52E-02	-4.90E-02	-6.04E-02	-7.09E-02

500 keV SS-Pb Exposure (Fractional Difference)

Full	1	2	3	4	5	6	7	8	9	10
1	5.98E-02	7.51E-02	6.45E-02	4.77E-02	3.07E-02	1.62E-02	5.15E-03	-1.77E-03	-4.16E-03	-1.64E-03
2	-2.40E-02	1.82E-02	2.36E-02	1.74E-02	8.21E-03	-3.60E-04	-6.52E-03	-9.29E-03	-7.97E-03	-2.02E-03
3	-5.45E-02	-6.20E-03	4.07E-03	2.12E-03	-3.39E-03	-8.69E-03	-1.19E-02	-1.19E-02	-7.94E-03	5.65E-04
4	-5.45E-02	-1.02E-02	-1.10E-03	-2.75E-03	-7.22E-03	-1.11E-02	-1.27E-02	-1.11E-02	-5.39E-03	4.97E-03
5	-3.81E-02	-2.29E-03	2.42E-03	-1.13E-03	-6.12E-03	-9.83E-03	-1.08E-02	-8.24E-03	-1.62E-03	1.00E-02
6	-1.62E-02	1.02E-02	9.62E-03	3.32E-03	-3.01E-03	-7.19E-03	-8.14E-03	-5.19E-03	2.21E-03	1.46E-02
7	2.16E-03	2.14E-02	1.64E-02	7.54E-03	-1.57E-04	-4.98E-03	-6.29E-03	-3.24E-03	4.49E-03	1.74E-02
8	1.01E-02	2.63E-02	1.89E-02	8.61E-03	8.95E-05	-5.13E-03	-6.40E-03	-3.47E-03	4.43E-03	1.76E-02
9	3.37E-03	2.18E-02	1.49E-02	4.71E-03	-3.74E-03	-9.04E-03	-1.00E-02	-6.91E-03	1.14E-03	1.45E-02
10	-1.91E-02	6.48E-03	2.97E-03	-5.36E-03	-1.27E-02	-1.70E-02	-1.78E-02	-1.42E-02	-5.96E-03	7.45E-03

Low	1	2	3	4	5	6	7	8	9	10
1	-6.72E-03	2.64E-02	2.65E-02	1.71E-02	6.09E-03	-3.16E-03	-9.12E-03	-1.09E-02	-7.91E-03	5.50E-04
2	-3.65E-02	5.86E-03	1.19E-02	7.00E-03	-2.29E-04	-6.30E-03	-9.42E-03	-8.54E-03	-2.90E-03	8.20E-03
3	-2.55E-02	9.77E-03	1.27E-02	6.93E-03	-2.17E-04	-5.63E-03	-7.76E-03	-5.70E-03	1.26E-03	1.38E-02
4	-8.76E-03	1.79E-02	1.61E-02	7.93E-03	-3.14E-04	-6.09E-03	-8.17E-03	-5.87E-03	1.55E-03	1.47E-02
5	-8.57E-03	1.61E-02	1.25E-02	3.17E-03	-5.62E-03	-1.17E-02	-1.39E-02	-1.15E-02	-4.33E-03	8.73E-03

High	1	2	3	4	5	6	7	8	9	10
6	-2.13E-02	5.64E-03	9.01E-03	6.38E-03	2.74E-03	2.38E-04	2.82E-05	2.86E-03	9.31E-03	2.00E-02
7	-1.13E-02	8.55E-03	7.36E-03	2.06E-03	-3.09E-03	-6.38E-03	-7.13E-03	-4.43E-03	2.04E-03	1.28E-02
8	-4.08E-03	1.29E-02	8.74E-03	1.33E-03	-5.21E-03	-9.40E-03	-1.06E-02	-8.40E-03	-2.19E-03	8.36E-03
9	-2.18E-03	1.61E-02	1.09E-02	2.28E-03	-5.24E-03	-1.04E-02	-1.19E-02	-1.02E-02	-4.33E-03	5.89E-03
10	-6.86E-03	1.62E-02	1.20E-02	3.34E-03	-4.56E-03	-9.94E-03	-1.23E-02	-1.07E-02	-5.23E-03	4.62E-03

1 MeV SS-Pb Exposure (Fractional Difference)

Full	1	2	3	4	5	6	7	8	9	10
1	8.56E-02	8.70E-02	7.07E-02	5.07E-02	3.19E-02	1.63E-02	4.96E-03	-1.80E-03	-3.38E-03	5.42E-04
2	-1.63E-02	1.89E-02	2.21E-02	1.49E-02	5.16E-03	-3.49E-03	-9.32E-03	-1.13E-02	-8.74E-03	-9.52E-04
3	-5.52E-02	-9.72E-03	3.92E-04	-1.57E-03	-7.04E-03	-1.21E-02	-1.49E-02	-1.40E-02	-8.73E-03	1.77E-03
4	-5.96E-02	-1.43E-02	-3.92E-03	-5.14E-03	-9.50E-03	-1.33E-02	-1.46E-02	-1.23E-02	-5.34E-03	6.93E-03
5	-4.61E-02	-5.53E-03	1.73E-03	-1.08E-03	-6.19E-03	-1.01E-02	-1.13E-02	-8.31E-03	-5.81E-04	1.27E-02
6	-2.63E-02	8.48E-03	1.15E-02	6.03E-03	-7.00E-04	-5.56E-03	-7.10E-03	-4.24E-03	3.67E-03	1.74E-02
7	-9.15E-03	2.10E-02	2.03E-02	1.22E-02	3.78E-03	-2.21E-03	-4.39E-03	-2.03E-03	5.68E-03	1.93E-02
8	-8.20E-04	2.73E-02	2.44E-02	1.46E-02	4.84E-03	-2.07E-03	-4.94E-03	-3.11E-03	4.17E-03	1.74E-02
9	-4.69E-03	2.44E-02	2.13E-02	1.11E-02	8.78E-04	-6.50E-03	-9.90E-03	-8.45E-03	-1.69E-03	1.10E-02
10	-2.16E-02	1.12E-02	1.00E-02	7.27E-04	-9.04E-03	-1.63E-02	-1.97E-02	-1.87E-02	-1.24E-02	-3.92E-04

High	1	2	3	4	5	6	7	8	9	10
6	-2.50E-02	1.43E-02	1.92E-02	1.38E-02	5.77E-03	-1.37E-03	-6.08E-03	-7.27E-03	-4.37E-03	3.15E-03
7	-2.60E-02	1.09E-02	1.49E-02	9.57E-03	2.40E-03	-3.55E-03	-6.75E-03	-6.42E-03	-1.77E-03	7.67E-03
8	-1.98E-02	1.20E-02	1.34E-02	7.18E-03	2.08E-05	-5.34E-03	-7.60E-03	-6.07E-03	-1.14E-05	1.10E-02
9	-1.04E-02	1.47E-02	1.26E-02	4.77E-03	-2.85E-03	-8.01E-03	-9.70E-03	-7.17E-03	2.78E-05	1.24E-02
10	-2.08E-03	1.60E-02	1.01E-02	5.07E-04	-7.72E-03	-1.28E-02	-1.40E-02	-1.08E-02	-2.62E-03	1.09E-02

Low	1	2	3	4	5	6	7	8	9	10
1	2.37E-02	2.91E-02	2.21E-02	1.22E-02	2.69E-03	-4.60E-03	-8.65E-03	-8.93E-03	-4.69E-03	4.55E-03
2	-3.21E-02	-2.59E-03	2.47E-03	-3.70E-04	-5.14E-03	-8.90E-03	-1.02E-02	-7.99E-03	-1.59E-03	9.73E-03
3	-3.28E-02	1.68E-03	7.70E-03	4.80E-03	-2.53E-04	-4.40E-03	-6.09E-03	-4.18E-03	2.01E-03	1.32E-02
4	-2.20E-02	1.35E-02	1.79E-02	1.28E-02	5.57E-03	-5.54E-04	-3.99E-03	-3.85E-03	7.05E-04	1.02E-02
5	-2.19E-02	1.61E-02	2.00E-02	1.35E-02	4.43E-03	-3.66E-03	-9.21E-03	-1.11E-02	-8.82E-03	-1.75E-03

2 MeV SS-Pb Exposure (Fractional Difference)

Full	1	2	3	4	5	6	7	8	9	10
1	1.44E-01	1.12E-01	8.42E-02	6.14E-02	4.24E-02	2.72E-02	1.55E-02	7.28E-03	2.62E-03	1.53E-03
2	1.44E-02	2.08E-02	1.68E-02	9.83E-03	2.62E-03	-3.57E-03	-7.93E-03	-9.98E-03	-9.23E-03	-5.44E-03
3	-3.99E-02	-1.84E-02	-1.26E-02	-1.25E-02	-1.42E-02	-1.58E-02	-1.62E-02	-1.48E-02	-1.08E-02	-3.93E-03
4	-5.42E-02	-2.76E-02	-1.88E-02	-1.63E-02	-1.61E-02	-1.60E-02	-1.48E-02	-1.17E-02	-6.11E-03	2.41E-03
5	-4.77E-02	-2.04E-02	-1.18E-02	-9.71E-03	-9.74E-03	-9.67E-03	-8.33E-03	-4.99E-03	1.02E-03	1.01E-02
6	-3.25E-02	-6.36E-03	4.05E-04	8.18E-04	-6.01E-04	-1.61E-03	-1.12E-03	1.59E-03	7.16E-03	1.60E-02
7	-1.70E-02	7.52E-03	1.20E-02	1.03E-02	7.03E-03	4.42E-03	3.57E-03	5.12E-03	9.68E-03	1.76E-02
8	-6.55E-03	1.65E-02	1.90E-02	1.52E-02	1.01E-02	5.79E-03	3.41E-03	3.54E-03	6.75E-03	1.33E-02
9	-4.21E-03	1.80E-02	1.89E-02	1.36E-02	6.83E-03	1.01E-03	-2.85E-03	-4.18E-03	-2.45E-03	2.59E-03
10	-1.10E-02	1.09E-02	1.10E-02	4.53E-03	-3.36E-03	-1.04E-02	-1.56E-02	-1.83E-02	-1.80E-02	-1.46E-02

Low	1	2	3	4	5	6	7	8	9	10
1	5.08E-02	3.53E-02	2.36E-02	1.44E-02	7.01E-03	1.47E-03	-2.40E-03	-4.57E-03	-4.84E-03	-3.21E-03
2	-2.39E-02	-1.15E-02	-7.82E-03	-7.00E-03	-6.99E-03	-6.93E-03	-6.19E-03	-4.42E-03	-1.21E-03	3.60E-03
3	-3.19E-02	-1.26E-02	-6.02E-03	-3.77E-03	-3.05E-03	-2.47E-03	-1.31E-03	8.45E-04	4.45E-03	9.68E-03
4	-1.75E-02	1.74E-03	6.13E-03	5.83E-03	4.09E-03	2.43E-03	1.58E-03	1.94E-03	3.90E-03	7.61E-03
5	-4.60E-03	1.27E-02	1.36E-02	9.57E-03	4.29E-03	-6.53E-04	-4.55E-03	-7.04E-03	-7.78E-03	-6.68E-03

High	1	2	3	4	5	6	7	8	9	10
6	-5.26E-03	1.06E-02	9.75E-03	4.71E-03	-6.18E-04	-4.48E-03	-6.13E-03	-5.14E-03	-1.07E-03	6.29E-03
7	-1.32E-02	6.29E-03	7.44E-03	3.53E-03	-1.14E-03	-4.67E-03	-6.19E-03	-5.20E-03	-1.25E-03	5.90E-03
8	-1.60E-02	6.22E-03	8.61E-03	5.24E-03	6.83E-04	-2.98E-03	-4.79E-03	-4.23E-03	-8.03E-04	5.72E-03
9	-1.70E-02	7.30E-03	1.06E-02	7.42E-03	2.73E-03	-1.30E-03	-3.64E-03	-3.75E-03	-1.12E-03	4.49E-03
10	-1.87E-02	7.37E-03	1.14E-02	8.36E-03	3.45E-03	-1.04E-03	-4.03E-03	-4.93E-03	-3.23E-03	1.30E-03

6 MeV SS-Pb Exposure (Fractional Difference)

Full	1	2	3	4	5	6	7	8	9	10
1	1.29E-01	1.30E-01	1.26E-01	1.18E-01	1.07E-01	9.23E-02	7.58E-02	5.78E-02	3.87E-02	1.90E-02
2	1.40E-02	2.99E-02	3.73E-02	3.87E-02	3.54E-02	2.87E-02	1.94E-02	8.33E-03	-4.08E-03	-1.72E-02
3	-4.13E-02	-2.05E-02	-8.57E-03	-2.86E-03	-1.66E-03	-3.83E-03	-8.48E-03	-1.48E-02	-2.24E-02	-3.05E-02
4	-6.18E-02	-4.02E-02	-2.71E-02	-1.96E-02	-1.61E-02	-1.56E-02	-1.72E-02	-2.01E-02	-2.39E-02	-2.79E-02
5	-6.06E-02	-4.04E-02	-2.80E-02	-2.04E-02	-1.61E-02	-1.41E-02	-1.37E-02	-1.41E-02	-1.48E-02	-1.53E-02
6	-4.62E-02	-2.90E-02	-1.85E-02	-1.20E-02	-8.04E-03	-5.64E-03	-4.10E-03	-2.77E-03	-1.15E-03	1.34E-03
7	-2.57E-02	-1.24E-02	-5.05E-03	-6.64E-04	2.05E-03	3.94E-03	5.64E-03	7.81E-03	1.09E-02	1.55E-02
8	-4.75E-03	3.61E-03	6.98E-03	8.30E-03	8.79E-03	9.16E-03	1.00E-02	1.19E-02	1.53E-02	2.09E-02
9	1.15E-02	1.42E-02	1.28E-02	1.02E-02	7.56E-03	5.41E-03	4.29E-03	4.72E-03	7.14E-03	1.21E-02
10	1.92E-02	1.58E-02	9.03E-03	1.85E-03	-4.79E-03	-1.04E-02	-1.45E-02	-1.67E-02	-1.68E-02	-1.40E-02

Low	1	2	3	4	5	6	7	8	9	10
1	3.04E-02	3.19E-02	3.22E-02	3.03E-02	2.64E-02	2.07E-02	1.38E-02	5.90E-03	-2.58E-03	-1.13E-02
2	-2.95E-02	-1.73E-02	-9.67E-03	-5.19E-03	-3.10E-03	-2.79E-03	-3.72E-03	-5.35E-03	-7.38E-03	-9.34E-03
3	-3.33E-02	-2.14E-02	-1.39E-02	-8.89E-03	-5.63E-03	-3.47E-03	-1.91E-03	-4.37E-04	1.28E-03	3.70E-03
4	-1.16E-02	-5.12E-03	-1.97E-03	-2.98E-04	6.88E-04	1.49E-03	2.51E-03	4.20E-03	6.86E-03	1.09E-02
5	1.54E-02	1.35E-02	9.43E-03	5.11E-03	1.16E-03	-2.12E-03	-4.41E-03	-5.39E-03	-4.82E-03	-2.33E-03

High	1	2	3	4	5	6	7	8	9	10
6	-1.58E-04	2.93E-03	4.02E-03	4.63E-03	4.99E-03	4.92E-03	4.23E-03	2.69E-03	-7.48E-05	-4.36E-03
7	-6.88E-03	-4.09E-03	-3.11E-03	-2.26E-03	-1.33E-03	-4.29E-04	1.80E-04	2.74E-04	-5.79E-04	-2.68E-03
8	-5.38E-03	-3.69E-03	-3.58E-03	-3.25E-03	-2.44E-03	-1.31E-03	-1.13E-04	8.95E-04	1.27E-03	6.58E-04
9	7.29E-04	7.11E-04	-6.90E-04	-1.52E-03	-1.53E-03	-8.67E-04	1.88E-04	1.36E-03	2.20E-03	2.31E-03
10	8.58E-03	6.32E-03	2.85E-03	2.44E-04	-1.23E-03	-1.75E-03	-1.58E-03	-1.04E-03	-5.92E-04	-6.35E-04

10 MeV SS-Pb Exposure (Fractional Difference)

Full	1	2	3	4	5	6	7	8	9	10
1	8.49E-02	1.01E-01	1.19E-01	1.32E-01	1.39E-01	1.38E-01	1.29E-01	1.10E-01	8.23E-02	4.45E-02
2	-1.64E-02	4.49E-03	2.41E-02	3.91E-02	4.84E-02	5.11E-02	4.67E-02	3.45E-02	1.37E-02	-1.63E-02
3	-6.27E-02	-4.32E-02	-2.50E-02	-1.05E-02	-4.10E-04	4.53E-03	3.70E-03	-3.58E-03	-1.83E-02	-4.15E-02
4	-7.59E-02	-6.01E-02	-4.48E-02	-3.19E-02	-2.21E-02	-1.58E-02	-1.38E-02	-1.67E-02	-2.59E-02	-4.27E-02
5	-6.81E-02	-5.71E-02	-4.57E-02	-3.52E-02	-2.63E-02	-1.93E-02	-1.51E-02	-1.43E-02	-1.82E-02	-2.86E-02
6	-4.71E-02	-4.19E-02	-3.50E-02	-2.77E-02	-2.03E-02	-1.35E-02	-7.80E-03	-3.87E-03	-3.08E-03	-7.49E-03
7	-1.91E-02	-2.03E-02	-1.85E-02	-1.50E-02	-1.03E-02	-4.60E-03	1.48E-03	7.32E-03	1.16E-02	1.22E-02
8	1.11E-02	3.12E-03	-1.01E-03	-2.25E-03	-1.17E-03	2.03E-03	6.84E-03	1.27E-02	1.83E-02	2.16E-02
9	3.98E-02	2.44E-02	1.36E-02	6.66E-03	2.86E-03	1.98E-03	3.53E-03	6.96E-03	1.10E-02	1.37E-02
10	6.38E-02	4.04E-02	2.24E-02	8.72E-03	-1.21E-03	-7.80E-03	-1.16E-02	-1.32E-02	-1.39E-02	-1.58E-02

Low	1	2	3	4	5	6	7	8	9	10
1	9.94E-03	1.48E-02	2.39E-02	3.14E-02	3.57E-02	3.58E-02	3.13E-02	2.20E-02	7.55E-03	-1.25E-02
2	-3.87E-02	-3.03E-02	-2.00E-02	-1.10E-02	-4.27E-03	-3.00E-04	6.39E-04	-1.57E-03	-7.32E-03	-1.71E-02
3	-3.38E-02	-2.97E-02	-2.33E-02	-1.68E-02	-1.11E-02	-6.48E-03	-2.99E-03	-7.11E-04	8.41E-05	-1.13E-03
4	-1.46E-03	-5.76E-03	-6.47E-03	-5.70E-03	-4.19E-03	-2.06E-03	6.09E-04	3.90E-03	7.68E-03	1.16E-02
5	4.06E-02	2.53E-02	1.47E-02	6.93E-03	1.15E-03	-2.80E-03	-5.03E-03	-5.45E-03	-4.15E-03	-1.45E-03

High	1	2	3	4	5	6	7	8	9	10
6	-2.30E-02	-1.45E-02	-6.10E-03	1.18E-03	6.90E-03	1.07E-02	1.20E-02	1.02E-02	4.20E-03	-7.62E-03
7	-1.67E-02	-1.37E-02	-9.66E-03	-5.54E-03	-1.81E-03	1.30E-03	3.30E-03	3.60E-03	1.05E-03	-6.09E-03
8	-3.18E-03	-5.79E-03	-6.38E-03	-5.75E-03	-4.36E-03	-2.36E-03	-2.08E-04	1.57E-03	1.85E-03	-1.16E-03
9	1.45E-02	6.10E-03	6.42E-04	-2.56E-03	-3.94E-03	-3.65E-03	-2.06E-03	3.60E-04	2.54E-03	2.69E-03
10	3.37E-02	1.94E-02	8.82E-03	1.39E-03	-3.29E-03	-5.39E-03	-5.26E-03	-3.31E-03	-5.41E-04	1.30E-03

Lead Followed by Stainless Steel

65 keV Pb-SS Exposure (Fractional Difference)

Full	1	2	3	4	5	6	7	8	9	10
1	8.25E-03	8.79E-03	9.65E-03	8.95E-03	6.94E-03	4.20E-03	1.26E-03	-1.47E-03	-3.54E-03	-4.84E-03
2	-2.25E-03	1.30E-03	3.88E-03	4.42E-03	3.43E-03	1.61E-03	-4.51E-04	-2.33E-03	-3.57E-03	-4.01E-03
3	-7.32E-03	-2.59E-03	7.50E-04	1.92E-03	1.54E-03	3.28E-04	-1.10E-03	-2.33E-03	-2.88E-03	-2.59E-03
4	-9.01E-03	-4.04E-03	-5.08E-04	8.83E-04	8.01E-04	-4.21E-05	-1.03E-03	-1.76E-03	-1.75E-03	-8.44E-04
5	-8.47E-03	-3.83E-03	-5.23E-04	7.93E-04	7.71E-04	1.10E-04	-5.91E-04	-9.33E-04	-4.64E-04	9.74E-04
6	-6.44E-03	-2.54E-03	2.37E-04	1.25E-03	1.10E-03	4.70E-04	-6.91E-05	-1.30E-04	7.20E-04	2.63E-03
7	-3.64E-03	-8.00E-04	1.22E-03	1.74E-03	1.33E-03	6.00E-04	1.69E-04	3.06E-04	1.47E-03	3.79E-03
8	-6.37E-04	9.10E-04	2.01E-03	1.90E-03	1.12E-03	2.42E-04	-1.87E-04	9.91E-05	1.53E-03	4.23E-03
9	1.83E-03	1.94E-03	1.99E-03	1.18E-03	-2.09E-05	-1.10E-03	-1.55E-03	-1.22E-03	5.32E-04	3.60E-03
10	3.08E-03	1.69E-03	6.62E-04	-8.65E-04	-2.51E-03	-3.79E-03	-4.33E-03	-3.81E-03	-1.88E-03	1.55E-03

Low	1	2	3	4	5	6	7	8	9	10
1	4.29E-03	2.43E-03	2.94E-03	2.96E-03	2.22E-03	9.87E-04	-3.81E-04	-1.58E-03	-2.24E-03	-2.25E-03
2	-3.51E-03	-2.63E-03	-5.98E-04	5.23E-04	6.93E-04	2.87E-04	-2.93E-04	-7.25E-04	-6.26E-04	1.32E-04
3	-4.31E-03	-3.18E-03	-1.05E-03	2.06E-04	5.71E-04	4.27E-04	1.79E-04	1.30E-04	6.70E-04	1.92E-03
4	-1.29E-03	-1.35E-03	-4.93E-05	6.30E-04	6.55E-04	3.40E-04	5.96E-05	8.33E-05	7.92E-04	2.28E-03
5	3.24E-03	1.09E-03	8.95E-04	5.14E-04	-1.99E-04	-1.01E-03	-1.60E-03	-1.74E-03	-1.09E-03	4.45E-04

High	1	2	3	4	5	6	7	8	9	10
6	5.21E-04	-5.02E-04	5.80E-04	1.34E-03	1.44E-03	1.00E-03	3.06E-04	-4.51E-04	-9.58E-04	-1.15E-03
7	-6.72E-04	-1.68E-03	-5.08E-04	4.06E-04	7.03E-04	5.07E-04	1.42E-04	-2.88E-04	-4.30E-04	-2.31E-04
8	-3.60E-04	-1.68E-03	-6.88E-04	1.51E-04	4.71E-04	3.82E-04	1.71E-04	-4.31E-05	7.82E-05	5.84E-04
9	8.22E-04	-1.08E-03	-4.81E-04	1.03E-04	2.95E-04	1.75E-04	1.72E-05	-1.50E-04	2.15E-04	9.60E-04
10	2.40E-03	-2.92E-04	-2.80E-04	-9.00E-05	-1.54E-04	-4.02E-04	-6.72E-04	-7.30E-04	-3.23E-04	5.94E-04

100keV Pb-SS Exposure (Fractional Difference)

Full	1	2	3	4	5	6	7	8	9	10
1	-3.79E-02	2.02E-01	1.48E-01	8.36E-02	2.96E-02	-1.12E-02	-3.87E-02	-5.31E-02	-5.35E-02	-3.79E-02
2	-6.76E-02	1.18E-01	8.88E-02	3.67E-02	-1.08E-02	-4.82E-02	-7.42E-02	-8.83E-02	-8.98E-02	-7.67E-02
3	-5.01E-02	8.95E-02	6.96E-02	2.21E-02	-2.38E-02	-6.09E-02	-8.74E-02	-1.03E-01	-1.06E-01	-9.45E-02
4	-2.63E-02	8.36E-02	7.33E-02	2.96E-02	-1.60E-02	-5.42E-02	-8.22E-02	-9.90E-02	-1.04E-01	-9.45E-02
5	-1.05E-02	7.76E-02	8.50E-02	5.03E-02	7.07E-03	-3.16E-02	-6.11E-02	-7.96E-02	-8.59E-02	-7.82E-02
6	-6.71E-03	5.32E-02	8.79E-02	7.30E-02	3.87E-02	3.04E-03	-2.63E-02	-4.56E-02	-5.29E-02	-4.60E-02
7	-9.49E-03	-7.64E-04	6.35E-02	8.17E-02	6.84E-02	4.35E-02	1.89E-02	1.42E-03	-5.20E-03	2.23E-03
8	-4.73E-03	-8.31E-02	-2.03E-03	5.71E-02	7.96E-02	7.84E-02	6.78E-02	5.80E-02	5.58E-02	6.65E-02
9	3.01E-02	-1.80E-01	-1.08E-01	-1.55E-02	5.21E-02	9.02E-02	1.08E-01	1.17E-01	1.27E-01	1.46E-01
10	1.31E-01	-2.72E-01	-2.36E-01	-1.34E-01	-2.86E-02	5.73E-02	1.19E-01	1.62E-01	1.98E-01	2.36E-01

Low	1	2	3	4	5	6	7	8	9	10
1	-2.66E-02	8.36E-02	5.41E-02	1.21E-02	-2.22E-02	-4.42E-02	-5.16E-02	-4.20E-02	-1.11E-02	4.90E-02
2	-3.92E-02	7.26E-02	4.87E-02	8.23E-03	-2.60E-02	-4.83E-02	-5.62E-02	-4.74E-02	-1.74E-02	4.13E-02
3	-3.10E-02	7.49E-02	5.62E-02	1.65E-02	-1.88E-02	-4.24E-02	-5.17E-02	-4.42E-02	-1.56E-02	4.14E-02
4	-3.63E-02	7.21E-02	6.66E-02	3.11E-02	-3.95E-03	-2.88E-02	-3.96E-02	-3.37E-02	-6.74E-03	4.84E-02
5	-8.21E-02	4.28E-02	6.52E-02	4.33E-02	1.31E-02	-1.07E-02	-2.22E-02	-1.74E-02	8.05E-03	6.13E-02

High	1	2	3	4	5	6	7	8	9	10
6	-8.25E-02	-8.43E-02	1.00E-02	2.93E-02	9.28E-03	-2.53E-02	-6.26E-02	-9.72E-02	-1.27E-01	-1.51E-01
7	-7.05E-02	-1.06E-01	-1.06E-02	3.07E-02	2.72E-02	6.41E-04	-3.43E-02	-6.97E-02	-1.02E-01	-1.29E-01
8	-1.06E-01	-1.64E-01	-6.21E-02	1.21E-02	4.01E-02	3.43E-02	1.00E-02	-2.14E-02	-5.35E-02	-8.25E-02
9	-1.09E-01	-2.33E-01	-1.43E-01	-4.22E-02	2.62E-02	5.64E-02	5.69E-02	3.94E-02	1.37E-02	-1.36E-02
10	-3.22E-02	-2.85E-01	-2.33E-01	-1.29E-01	-2.78E-02	4.67E-02	8.77E-02	9.99E-02	9.26E-02	7.51E-02

500 keV Pb-SS Exposure (Fractional Difference)

Full	1	2	3	4	5	6	7	8	9	10
1	9.12E-01	4.64E-01	2.19E-01	6.98E-02	-2.21E-02	-7.32E-02	-8.80E-02	-5.10E-02	-1.27E-01	5.02E-02
2	6.81E-01	3.11E-01	1.06E-01	-1.96E-02	-9.62E-02	-1.37E-01	-1.48E-01	-1.26E-01	-5.02E-03	7.86E-02
3	5.49E-01	2.25E-01	4.48E-02	-6.36E-02	-1.27E-01	-1.55E-01	-1.51E-01	-1.07E-01	2.39E-02	9.50E-02
4	4.74E-01	1.79E-01	1.63E-02	-7.90E-02	-1.31E-01	-1.47E-01	-1.29E-01	-6.82E-02	5.41E-02	-3.49E-03
5	4.35E-01	1.59E-01	8.88E-03	-7.64E-02	-1.19E-01	-1.26E-01	-9.88E-02	-3.29E-02	6.55E-02	4.71E-02
6	4.19E-01	1.56E-01	1.50E-02	-6.31E-02	-9.89E-02	-1.00E-01	-6.92E-02	-7.43E-03	6.43E-02	3.31E-02
7	4.19E-01	1.65E-01	2.92E-02	-4.40E-02	-7.58E-02	-7.47E-02	-4.47E-02	7.46E-03	5.46E-02	1.21E-02
8	4.30E-01	1.80E-01	4.79E-02	-2.27E-02	-5.29E-02	-5.21E-02	-2.67E-02	1.30E-02	3.88E-02	-1.21E-02
9	4.46E-01	1.99E-01	6.82E-02	-1.55E-03	-3.22E-02	-3.41E-02	-1.54E-02	1.11E-02	1.90E-02	-3.81E-02
10	4.67E-01	2.19E-01	8.84E-02	1.79E-02	-1.47E-02	-2.10E-02	-1.05E-02	3.32E-03	-3.39E-03	-6.49E-02

Low	1	2	3	4	5	6	7	8	9	10
1	2.80E-03	1.47E-02	2.15E-02	2.27E-02	2.03E-02	1.56E-02	9.74E-03	3.18E-03	-3.74E-03	-1.09E-02
2	-3.60E-02	-1.94E-02	-7.43E-03	-1.04E-03	1.72E-03	2.19E-03	1.37E-03	-3.29E-04	-2.54E-03	-5.10E-03
3	-3.04E-02	-2.22E-02	-1.35E-02	-7.58E-03	-3.88E-03	-1.58E-03	-4.95E-05	9.30E-04	1.62E-03	2.13E-03
4	9.80E-04	-7.06E-03	-6.70E-03	-5.17E-03	-3.58E-03	-1.98E-03	-2.62E-04	1.56E-03	3.54E-03	5.66E-03
5	4.67E-02	1.72E-02	5.70E-03	1.90E-05	-2.87E-03	-4.08E-03	-4.00E-03	-3.02E-03	-1.31E-03	9.62E-04

High	1	2	3	4	5	6	7	8	9	10
6	-1.66E-02	-6.07E-03	2.54E-03	6.79E-03	7.90E-03	6.91E-03	4.71E-03	1.76E-03	-1.62E-03	-5.01E-03
7	-1.33E-02	-8.49E-03	-2.27E-03	1.37E-03	2.81E-03	2.77E-03	1.84E-03	5.08E-04	-1.06E-03	-2.68E-03
8	-4.17E-03	-6.33E-03	-3.37E-03	-1.09E-03	1.16E-04	4.97E-04	4.40E-04	2.41E-04	1.05E-04	1.37E-04
9	9.11E-03	-1.12E-03	-2.17E-03	-1.88E-03	-1.52E-03	-1.14E-03	-7.22E-04	-8.49E-05	8.77E-04	2.22E-03
10	2.49E-02	5.74E-03	3.11E-05	-2.24E-03	-3.16E-03	-3.26E-03	-2.78E-03	-1.67E-03	5.59E-05	2.39E-03

1 MeV Pb-SS Exposure (Fractional Difference)

Full	1	2	3	4	5	6	7	8	9	10
1	1.02E-01	1.08E-01	1.02E-01	8.79E-02	7.07E-02	5.23E-02	3.39E-02	1.64E-02	-2.58E-05	-1.51E-02
2	-5.58E-03	2.33E-02	3.41E-02	3.41E-02	2.83E-02	1.94E-02	9.19E-03	-1.41E-03	-1.17E-02	-2.14E-02
3	-5.43E-02	-1.95E-02	-1.92E-03	4.90E-03	5.35E-03	2.31E-03	-2.67E-03	-8.49E-03	-1.44E-02	-2.01E-02
4	-7.08E-02	-3.75E-02	-1.82E-02	-8.50E-03	-4.67E-03	-4.26E-03	-5.82E-03	-8.31E-03	-1.11E-02	-1.37E-02
5	-6.71E-02	-3.95E-02	-2.17E-02	-1.16E-02	-6.47E-03	-4.20E-03	-3.66E-03	-3.92E-03	-4.34E-03	-4.60E-03
6	-5.05E-02	-3.15E-02	-1.75E-02	-8.78E-03	-3.73E-03	-8.39E-04	8.07E-04	1.95E-03	3.12E-03	4.61E-03
7	-2.62E-02	-1.79E-02	-9.38E-03	-3.47E-03	2.60E-04	2.82E-03	4.77E-03	6.59E-03	8.69E-03	1.14E-02
8	1.29E-03	-2.70E-03	-9.32E-04	1.04E-03	2.63E-03	4.03E-03	5.50E-03	7.35E-03	9.89E-03	1.32E-02
9	2.80E-02	1.06E-02	4.74E-03	2.05E-03	6.96E-04	3.03E-04	7.24E-04	2.07E-03	4.46E-03	7.96E-03
10	5.03E-02	1.91E-02	5.01E-03	-2.88E-03	-7.66E-03	-1.03E-02	-1.14E-02	-1.11E-02	-9.30E-03	-6.12E-03

Low	1	2	3	4	5	6	7	8	9	10
1	1.98E-02	2.93E-02	3.19E-02	2.92E-02	2.36E-02	1.66E-02	8.93E-03	1.16E-03	-6.42E-03	-1.37E-02
2	-4.08E-02	-2.04E-02	-7.79E-03	-1.36E-03	1.22E-03	1.59E-03	5.79E-04	-1.17E-03	-3.27E-03	-5.58E-03
3	-3.83E-02	-2.63E-02	-1.59E-02	-8.89E-03	-4.40E-03	-1.44E-03	4.71E-04	1.75E-03	2.72E-03	3.45E-03
4	-3.45E-03	-9.27E-03	-7.90E-03	-5.52E-03	-3.18E-03	-9.90E-04	1.04E-03	3.02E-03	5.05E-03	7.08E-03
5	4.55E-02	1.68E-02	5.19E-03	-3.63E-04	-3.06E-03	-4.09E-03	-4.09E-03	-3.33E-03	-1.94E-03	-1.61E-04

High	1	2	3	4	5	6	7	8	9	10
6	-9.17E-03	-1.69E-03	4.64E-03	7.44E-03	7.58E-03	6.06E-03	3.54E-03	5.87E-04	-2.38E-03	-5.18E-03
7	-1.06E-02	-6.80E-03	-1.60E-03	1.43E-03	2.41E-03	2.18E-03	1.20E-03	-1.42E-04	-1.47E-03	-2.50E-03
8	-4.87E-03	-6.16E-03	-3.17E-03	-9.29E-04	2.03E-04	5.66E-04	4.55E-04	2.39E-04	2.14E-04	4.93E-04
9	5.44E-03	-2.12E-03	-2.24E-03	-1.48E-03	-8.97E-04	-4.85E-04	-1.58E-04	3.27E-04	1.18E-03	2.50E-03
10	1.80E-02	3.24E-03	-7.46E-04	-2.08E-03	-2.56E-03	-2.57E-03	-2.21E-03	-1.40E-03	1.27E-05	2.05E-03

2 MeV Pb-SS Exposure (Fractional Difference)

Full	1	2	3	4	5	6	7	8	9	10
1	1.26E-01	1.13E-01	9.71E-02	7.85E-02	5.93E-02	4.04E-02	2.25E-02	6.05E-03	-8.86E-03	-2.22E-02
2	9.78E-03	2.66E-02	3.19E-02	2.97E-02	2.32E-02	1.45E-02	4.88E-03	-4.77E-03	-1.40E-02	-2.24E-02
3	-4.41E-02	-1.82E-02	-3.52E-03	2.68E-03	3.55E-03	1.22E-03	-2.86E-03	-7.76E-03	-1.28E-02	-1.76E-02
4	-6.27E-02	-3.69E-02	-1.94E-02	-9.51E-03	-4.71E-03	-3.26E-03	-3.83E-03	-5.50E-03	-7.59E-03	-9.67E-03
5	-5.93E-02	-3.88E-02	-2.26E-02	-1.20E-02	-5.63E-03	-2.29E-03	-8.47E-04	-4.74E-04	-5.66E-04	-7.08E-04
6	-4.24E-02	-3.03E-02	-1.79E-02	-8.77E-03	-2.64E-03	1.19E-03	3.52E-03	4.99E-03	6.13E-03	7.26E-03
7	-1.83E-02	-1.67E-02	-9.84E-03	-3.60E-03	1.09E-03	4.37E-03	6.72E-03	8.55E-03	1.03E-02	1.22E-02
8	7.45E-03	-2.48E-03	-2.10E-03	2.62E-04	2.67E-03	4.68E-03	6.40E-03	8.05E-03	9.88E-03	1.21E-02
9	3.06E-02	8.88E-03	2.27E-03	2.67E-04	-1.04E-04	1.65E-04	8.29E-04	1.89E-03	3.45E-03	5.60E-03
10	4.73E-02	1.43E-02	8.04E-04	-5.69E-03	-9.02E-03	-1.07E-02	-1.14E-02	-1.11E-02	-1.01E-02	-8.23E-03

Low	1	2	3	4	5	6	7	8	9	10
1	3.21E-02	3.18E-02	2.95E-02	2.46E-02	1.84E-02	1.17E-02	4.85E-03	-1.63E-03	-7.58E-03	-1.30E-02
2	-3.30E-02	-1.80E-02	-7.85E-03	-2.31E-03	1.44E-04	6.72E-04	1.06E-04	-9.90E-04	-2.25E-03	-3.49E-03
3	-3.32E-02	-2.42E-02	-1.49E-02	-8.10E-03	-3.52E-03	-5.45E-04	1.42E-03	2.76E-03	3.84E-03	4.81E-03
4	-2.78E-03	-8.94E-03	-7.26E-03	-4.48E-03	-1.89E-03	2.42E-04	2.01E-03	3.58E-03	5.13E-03	6.74E-03
5	3.74E-02	1.26E-02	3.35E-03	-6.74E-04	-2.51E-03	-3.34E-03	-3.57E-03	-3.35E-03	-2.71E-03	-1.69E-03

High	1	2	3	4	5	6	7	8	9	10
6	-4.84E-03	9.86E-05	5.42E-03	7.74E-03	7.49E-03	5.48E-03	2.54E-03	-6.79E-04	-3.67E-03	-6.14E-03
7	-8.41E-03	-6.18E-03	-1.25E-03	1.82E-03	2.86E-03	2.42E-03	1.16E-03	-3.46E-04	-1.64E-03	-2.43E-03
8	-4.16E-03	-6.41E-03	-3.27E-03	-6.43E-04	7.29E-04	1.06E-03	8.22E-04	4.77E-04	4.27E-04	9.24E-04
9	4.83E-03	-3.14E-03	-2.84E-03	-1.50E-03	-5.20E-04	-3.44E-05	2.33E-04	6.07E-04	1.41E-03	2.87E-03
10	1.56E-02	1.15E-03	-2.09E-03	-2.67E-03	-2.60E-03	-2.42E-03	-2.04E-03	-1.29E-03	7.47E-05	2.21E-03

6 MeV Pb-SS Exposure (Fractional Difference)

Full	1	2	3	4	5	6	7	8	9	10
1	7.53E-02	6.23E-02	5.13E-02	4.03E-02	2.98E-02	2.04E-02	1.24E-02	6.38E-03	2.38E-03	5.85E-04
2	-8.42E-04	6.85E-03	9.09E-03	7.51E-03	4.09E-03	2.70E-04	-3.09E-03	-5.31E-03	-5.99E-03	-4.82E-03
3	-3.19E-02	-1.80E-02	-1.04E-02	-7.70E-03	-7.60E-03	-8.49E-03	-9.33E-03	-9.34E-03	-8.04E-03	-5.06E-03
4	-3.69E-02	-2.32E-02	-1.48E-02	-1.08E-02	-9.53E-03	-9.30E-03	-9.08E-03	-8.11E-03	-5.87E-03	-1.99E-03
5	-2.79E-02	-1.75E-02	-1.02E-02	-6.79E-03	-5.65E-03	-5.41E-03	-5.11E-03	-3.98E-03	-1.56E-03	2.54E-03
6	-1.38E-02	-7.41E-03	-2.17E-03	1.00E-04	4.54E-04	1.22E-04	-1.62E-05	7.43E-04	2.87E-03	6.72E-03
7	-8.46E-04	1.90E-03	5.20E-03	6.26E-03	5.72E-03	4.66E-03	3.88E-03	4.06E-03	5.63E-03	8.95E-03
8	6.91E-03	6.85E-03	8.77E-03	8.97E-03	7.78E-03	6.12E-03	4.76E-03	4.35E-03	5.31E-03	7.99E-03
9	6.84E-03	5.06E-03	6.35E-03	6.26E-03	4.83E-03	2.91E-03	1.20E-03	3.46E-04	7.84E-04	2.84E-03
10	-2.10E-03	-4.54E-03	-3.13E-03	-2.89E-03	-4.04E-03	-5.82E-03	-7.56E-03	-8.60E-03	-8.51E-03	-6.95E-03

Low	1	2	3	4	5	6	7	8	9	10
1	3.43E-02	2.19E-02	1.53E-02	1.04E-02	6.27E-03	2.81E-03	1.23E-06	-2.07E-03	-3.40E-03	-3.97E-03
2	-1.40E-02	-9.95E-03	-6.43E-03	-4.43E-03	-3.43E-03	-2.84E-03	-2.33E-03	-1.58E-03	-4.34E-04	1.20E-03
3	-2.00E-02	-1.35E-02	-8.11E-03	-4.76E-03	-2.75E-03	-1.38E-03	-1.92E-04	1.15E-03	2.84E-03	4.99E-03
4	-7.50E-03	-4.27E-03	-9.78E-04	6.94E-04	1.27E-03	1.40E-03	1.47E-03	1.84E-03	2.65E-03	4.00E-03
5	7.73E-03	5.98E-03	5.80E-03	4.63E-03	2.69E-03	5.63E-04	-1.41E-03	-2.92E-03	-3.85E-03	-4.11E-03

High	1	2	3	4	5	6	7	8	9	10
6	-1.37E-03	-9.02E-04	8.42E-04	1.14E-03	4.17E-04	-5.26E-04	-1.12E-03	-9.12E-04	3.98E-04	3.00E-03
7	-3.77E-04	-9.84E-04	5.51E-04	7.98E-04	-2.30E-05	-1.16E-03	-2.05E-03	-2.21E-03	-1.33E-03	7.79E-04
8	1.32E-03	2.49E-05	1.63E-03	2.04E-03	1.27E-03	3.66E-05	-1.08E-03	-1.58E-03	-1.15E-03	4.52E-04
9	8.93E-04	-4.71E-04	1.67E-03	2.62E-03	2.23E-03	1.17E-03	3.22E-05	-6.51E-04	-5.30E-04	6.38E-04
10	-3.26E-03	-4.07E-03	-8.92E-04	1.06E-03	1.46E-03	9.18E-04	5.16E-05	-5.65E-04	-5.61E-04	3.35E-04

10 MeV Pb-SS Exposure (Fractional Difference)

Full	1	2	3	4	5	6	7	8	9	10
1	2.33E-02	5.53E-02	6.09E-02	5.39E-02	4.16E-02	2.84E-02	1.67E-02	8.13E-03	3.94E-03	5.05E-03
2	-4.11E-02	4.78E-03	2.06E-02	2.11E-02	1.46E-02	5.85E-03	-2.13E-03	-7.52E-03	-8.93E-03	-5.25E-03
3	-6.18E-02	-1.62E-02	2.14E-03	5.35E-03	1.33E-03	-5.15E-03	-1.11E-02	-1.47E-02	-1.43E-02	-8.89E-03
4	-5.76E-02	-1.83E-02	-1.77E-03	1.41E-03	-2.07E-03	-7.80E-03	-1.29E-02	-1.55E-02	-1.41E-02	-7.48E-03
5	-4.09E-02	-1.03E-02	2.71E-03	4.45E-03	5.09E-04	-5.19E-03	-1.00E-02	-1.22E-02	-1.01E-02	-2.78E-03
6	-2.08E-02	9.48E-04	1.01E-02	1.01E-02	5.50E-03	-3.98E-04	-5.14E-03	-7.00E-03	-4.54E-03	3.44E-03
7	-3.95E-03	1.00E-02	1.59E-02	1.46E-02	9.55E-03	3.67E-03	-8.29E-04	-2.30E-03	6.54E-04	9.26E-03
8	5.22E-03	1.30E-02	1.66E-02	1.48E-02	9.95E-03	4.61E-03	7.64E-04	-2.07E-05	3.64E-03	1.30E-02
9	3.81E-03	7.15E-03	9.68E-03	8.30E-03	4.50E-03	3.43E-04	-2.32E-03	-2.01E-03	2.69E-03	1.30E-02
10	-9.52E-03	-8.91E-03	-6.30E-03	-6.35E-03	-8.37E-03	-1.07E-02	-1.16E-02	-9.73E-03	-3.65E-03	7.90E-03

Low	1	2	3	4	5	6	7	8	9	10
1	3.61E-02	2.46E-02	1.60E-02	8.67E-03	2.68E-03	-1.72E-03	-4.19E-03	-4.40E-03	-1.97E-03	3.47E-03
2	-1.45E-02	-5.81E-03	-3.19E-03	-3.79E-03	-5.52E-03	-7.01E-03	-7.36E-03	-5.93E-03	-2.13E-03	4.52E-03
3	-2.26E-02	-7.53E-03	-1.04E-03	2.41E-04	-8.15E-04	-2.34E-03	-3.11E-03	-2.30E-03	7.53E-04	6.58E-03
4	-1.70E-02	-3.51E-04	7.19E-03	8.48E-03	6.57E-03	3.63E-03	1.17E-03	5.57E-05	1.06E-03	4.72E-03
5	-1.59E-02	1.28E-03	9.54E-03	1.07E-02	7.92E-03	3.49E-03	-9.41E-04	-4.33E-03	-5.86E-03	-4.97E-03

High	1	2	3	4	5	6	7	8	9	10
6	-2.46E-02	-1.91E-03	8.82E-03	1.03E-02	6.72E-03	1.61E-03	-2.61E-03	-4.18E-03	-1.66E-03	6.18E-03
7	-1.26E-02	2.18E-03	9.31E-03	9.06E-03	4.64E-03	-9.98E-04	-5.62E-03	-7.57E-03	-5.45E-03	1.92E-03
8	-4.43E-03	4.67E-03	9.72E-03	8.87E-03	4.44E-03	-1.04E-03	-5.49E-03	-7.33E-03	-5.18E-03	2.14E-03
9	-2.15E-03	3.24E-03	7.56E-03	7.20E-03	3.67E-03	-8.56E-04	-4.46E-03	-5.58E-03	-2.86E-03	4.91E-03
10	-6.43E-03	-3.27E-03	1.40E-03	2.45E-03	6.64E-04	-2.15E-03	-4.21E-03	-3.98E-03	-1.08E-04	8.66E-03

Aluminum Followed by Stainless Steel

65 keV Al-SS Exposure (Fractional Difference)

Full	1	2	3	4	5	6	7	8	9	10
1	1.11E-01	1.01E-01	7.79E-02	5.50E-02	3.61E-02	2.20E-02	1.28E-02	8.64E-03	9.56E-03	1.56E-02
2	1.09E-02	3.35E-02	2.74E-02	1.53E-02	3.80E-03	-4.71E-03	-9.39E-03	-9.66E-03	-5.10E-03	4.56E-03
3	-3.76E-02	-8.03E-04	1.69E-03	-4.85E-03	-1.24E-02	-1.78E-02	-1.98E-02	-1.76E-02	-1.05E-02	1.77E-03
4	-5.51E-02	-1.22E-02	-6.22E-03	-1.06E-02	-1.65E-02	-2.06E-02	-2.14E-02	-1.78E-02	-9.15E-03	5.05E-03
5	-5.30E-02	-8.62E-03	-2.22E-03	-6.58E-03	-1.27E-02	-1.67E-02	-1.72E-02	-1.31E-02	-3.63E-03	1.18E-02
6	-4.00E-02	3.41E-03	8.28E-03	2.47E-03	-4.77E-03	-9.81E-03	-1.04E-02	-6.65E-03	2.78E-03	1.94E-02
7	-2.37E-02	1.77E-02	1.98E-02	1.22E-02	2.99E-03	-2.87E-03	-5.03E-03	-1.84E-03	8.13E-03	2.43E-02
8	-1.04E-02	2.81E-02	2.76E-02	1.79E-02	6.83E-03	-4.28E-04	-3.66E-03	-1.23E-03	8.28E-03	2.43E-02
9	-6.84E-03	2.94E-02	2.68E-02	1.55E-02	3.09E-03	-5.33E-03	-9.53E-03	-7.92E-03	9.17E-04	1.64E-02
10	-1.77E-02	1.75E-02	1.42E-02	2.22E-03	-1.08E-02	-1.99E-02	-2.48E-02	-2.39E-02	-1.58E-02	-1.08E-03

Low	1	2	3	4	5	6	7	8	9	10
1	1.29E-02	2.62E-02	2.05E-02	1.11E-02	2.12E-03	-4.72E-03	-8.86E-03	-9.86E-03	-7.36E-03	-1.19E-03
2	-2.97E-02	4.70E-03	8.64E-03	4.35E-03	-1.33E-03	-5.69E-03	-7.64E-03	-6.45E-03	-1.60E-03	7.16E-03
3	-3.47E-02	4.59E-03	9.96E-03	6.03E-03	5.27E-04	-3.48E-03	-4.80E-03	-2.65E-03	3.53E-03	1.41E-02
4	-2.13E-02	1.40E-02	1.57E-02	8.99E-03	1.61E-03	-3.54E-03	-5.38E-03	-3.20E-03	3.52E-03	1.51E-02
5	-6.30E-03	2.03E-02	1.59E-02	5.00E-03	-5.15E-03	-1.21E-02	-1.50E-02	-1.33E-02	-6.61E-03	5.35E-03

High	1	2	3	4	5	6	7	8	9	10
6	-2.75E-02	1.45E-02	1.73E-02	9.21E-03	-8.45E-05	-6.88E-03	-8.87E-03	-6.21E-03	2.54E-03	1.89E-02
7	-2.81E-02	1.38E-02	1.57E-02	7.56E-03	-2.41E-03	-8.99E-03	-1.18E-02	-8.99E-03	7.90E-04	1.71E-02
8	-2.30E-02	1.74E-02	1.79E-02	8.67E-03	-2.21E-03	-9.45E-03	-1.27E-02	-1.01E-02	-3.23E-04	1.63E-02
9	-1.69E-02	2.17E-02	2.05E-02	9.87E-03	-2.10E-03	-1.02E-02	-1.40E-02	-1.19E-02	-2.35E-03	1.43E-02
10	-1.31E-02	2.35E-02	2.07E-02	8.79E-03	-4.22E-03	-1.32E-02	-1.77E-02	-1.61E-02	-6.90E-03	9.55E-03

100 keV Al-SS Exposure (Fractional Difference)

Full	1	2	3	4	5	6	7	8	9	10
1	1.30E-01	1.24E-01	1.00E-01	7.42E-02	5.08E-02	3.16E-02	1.73E-02	8.44E-03	5.39E-03	8.86E-03
2	6.01E-04	3.67E-02	3.63E-02	2.54E-02	1.25E-02	1.18E-03	-6.80E-03	-1.03E-02	-8.33E-03	-1.52E-05
3	-5.70E-02	-4.74E-03	4.80E-03	7.23E-04	-6.99E-03	-1.41E-02	-1.84E-02	-1.84E-02	-1.30E-02	-9.47E-04
4	-7.39E-02	-1.69E-02	-4.75E-03	-6.86E-03	-1.31E-02	-1.84E-02	-2.08E-02	-1.90E-02	-1.11E-02	3.67E-03
5	-6.67E-02	-1.09E-02	-1.59E-04	-3.53E-03	-1.00E-02	-1.57E-02	-1.76E-02	-1.46E-02	-5.49E-03	1.17E-02
6	-4.73E-02	4.61E-03	1.16E-02	5.43E-03	-2.90E-03	-9.61E-03	-1.20E-02	-8.69E-03	1.21E-03	1.98E-02
7	-2.52E-02	2.18E-02	2.43E-02	1.48E-02	4.21E-03	-4.01E-03	-7.19E-03	-4.20E-03	5.95E-03	2.54E-02
8	-9.09E-03	3.37E-02	3.23E-02	2.00E-02	7.23E-03	-2.46E-03	-6.58E-03	-4.39E-03	5.92E-03	2.56E-02
9	-5.94E-03	3.45E-02	3.10E-02	1.69E-02	2.84E-03	-7.85E-03	-1.27E-02	-1.11E-02	-1.15E-03	1.83E-02
10	-2.05E-02	2.03E-02	1.71E-02	2.89E-03	-1.13E-02	-2.23E-02	-2.75E-02	-2.60E-02	-1.69E-02	1.95E-03

Low	1	2	3	4	5	6	7	8	9	10
1	1.18E-02	3.73E-02	3.43E-02	2.29E-02	1.01E-02	-9.71E-04	-8.70E-03	-1.20E-02	-9.85E-03	-1.36E-03
2	-4.61E-02	3.30E-03	1.22E-02	8.02E-03	2.43E-04	-6.80E-03	-1.10E-02	-1.07E-02	-4.96E-03	7.60E-03
3	-4.62E-02	5.05E-03	1.37E-02	9.17E-03	1.51E-03	-5.07E-03	-8.34E-03	-6.72E-03	9.14E-04	1.60E-02
4	-2.64E-02	1.87E-02	2.21E-02	1.39E-02	3.67E-03	-4.26E-03	-8.06E-03	-6.69E-03	1.59E-03	1.76E-02
5	-1.38E-02	2.47E-02	2.28E-02	1.06E-02	-2.04E-03	-1.21E-02	-1.72E-02	-1.63E-02	-8.79E-03	7.37E-03

High	1	2	3	4	5	6	7	8	9	10
6	-3.95E-02	1.67E-02	2.48E-02	1.79E-02	7.79E-03	-1.45E-03	-6.95E-03	-7.48E-03	-2.15E-03	1.08E-02
7	-3.88E-02	1.45E-02	2.08E-02	1.32E-02	3.19E-03	-5.45E-03	-9.85E-03	-8.84E-03	-1.51E-03	1.40E-02
8	-2.97E-02	1.83E-02	2.11E-02	1.16E-02	6.30E-04	-8.12E-03	-1.20E-02	-1.02E-02	-1.06E-03	1.67E-02
9	-1.72E-02	2.39E-02	2.21E-02	9.93E-03	-2.41E-03	-1.17E-02	-1.54E-02	-1.30E-02	-2.57E-03	1.70E-02
10	-6.63E-03	2.67E-02	2.03E-02	5.35E-03	-8.44E-03	-1.83E-02	-2.21E-02	-1.89E-02	-7.91E-03	1.31E-02

500 keV Al-SS Exposure (Fractional Difference)

Full	1	2	3	4	5	6	7	8	9	10
1	2.23E-01	1.70E-01	1.32E-01	1.02E-01	7.86E-02	5.89E-02	4.24E-02	2.86E-02	1.72E-02	7.91E-03
2	3.99E-02	3.63E-02	2.85E-02	2.02E-02	1.24E-02	5.51E-03	-1.16E-04	-4.52E-03	-7.69E-03	-9.63E-03
3	-3.46E-02	-2.17E-02	-1.83E-02	-1.77E-02	-1.81E-02	-1.84E-02	-1.82E-02	-1.73E-02	-1.55E-02	-1.27E-02
4	-5.60E-02	-3.83E-02	-3.14E-02	-2.79E-02	-2.55E-02	-2.31E-02	-2.02E-02	-1.67E-02	-1.22E-02	-6.76E-03
5	-5.16E-02	-3.30E-02	-2.60E-02	-2.24E-02	-1.97E-02	-1.68E-02	-1.33E-02	-8.90E-03	-3.48E-03	3.08E-03
6	-3.65E-02	-1.81E-02	-1.23E-02	-9.92E-03	-8.23E-03	-6.21E-03	-3.31E-03	6.24E-04	5.75E-03	1.21E-02
7	-2.01E-02	-2.05E-03	2.26E-03	2.96E-03	2.96E-03	3.40E-03	4.86E-03	7.45E-03	1.13E-02	1.66E-02
8	-8.08E-03	9.91E-03	1.28E-02	1.17E-02	9.76E-03	8.23E-03	7.74E-03	8.41E-03	1.04E-02	1.37E-02
9	-3.54E-03	1.46E-02	1.63E-02	1.35E-02	9.60E-03	5.97E-03	3.28E-03	1.69E-03	1.37E-03	2.34E-03
10	-7.89E-03	1.05E-02	1.14E-02	7.04E-03	1.27E-03	-4.44E-03	-9.36E-03	-1.33E-02	-1.61E-02	-1.77E-02

Low	1	2	3	4	5	6	7	8	9	10
1	7.24E-02	5.25E-02	3.91E-02	2.87E-02	2.04E-02	1.34E-02	7.31E-03	1.83E-03	-3.32E-03	-8.49E-03
2	-2.80E-02	-1.82E-02	-1.38E-02	-1.11E-02	-9.07E-03	-7.28E-03	-5.55E-03	-3.99E-03	-2.74E-03	-1.97E-03
3	-3.79E-02	-2.42E-02	-1.79E-02	-1.36E-02	-9.86E-03	-6.28E-03	-2.64E-03	8.59E-04	4.13E-03	6.94E-03
4	-1.53E-02	-4.89E-03	-2.49E-03	-1.62E-03	-7.54E-04	4.98E-04	2.20E-03	4.11E-03	6.03E-03	7.73E-03
5	9.79E-03	1.58E-02	1.27E-02	8.26E-03	4.25E-03	1.00E-03	-1.43E-03	-3.36E-03	-4.99E-03	-6.64E-03

High	1	2	3	4	5	6	7	8	9	10
6	7.18E-03	1.12E-02	6.33E-03	1.27E-03	-2.23E-03	-3.86E-03	-3.67E-03	-2.09E-03	5.23E-04	3.72E-03
7	-4.53E-03	4.71E-03	2.82E-03	-5.74E-04	-3.17E-03	-4.37E-03	-4.09E-03	-2.67E-03	-3.78E-04	2.37E-03
8	-1.02E-02	3.34E-03	3.68E-03	1.40E-03	-7.78E-04	-2.01E-03	-2.09E-03	-1.27E-03	2.52E-04	2.08E-03
9	-1.38E-02	3.42E-03	5.61E-03	4.16E-03	2.15E-03	6.25E-04	-7.90E-05	-1.23E-04	3.26E-04	9.54E-04
10	-1.79E-02	2.56E-03	6.43E-03	5.63E-03	3.65E-03	1.69E-03	2.18E-04	-8.64E-04	-1.65E-03	-2.40E-03

1 MeV Al-SS Exposure (Fractional Difference)

Full	1	2	3	4	5	6	7	8	9	10
1	2.28E-01	1.66E-01	1.26E-01	9.54E-02	7.15E-02	5.20E-02	3.57E-02	2.16E-02	9.31E-03	-1.81E-03
2	4.18E-02	3.38E-02	2.54E-02	1.78E-02	1.11E-02	5.21E-03	-4.95E-05	-4.80E-03	-9.15E-03	-1.33E-02
3	-3.47E-02	-2.51E-02	-2.07E-02	-1.82E-02	-1.66E-02	-1.54E-02	-1.45E-02	-1.38E-02	-1.32E-02	-1.30E-02
4	-5.71E-02	-4.28E-02	-3.45E-02	-2.83E-02	-2.33E-02	-1.89E-02	-1.50E-02	-1.15E-02	-8.35E-03	-5.66E-03
5	-5.20E-02	-3.82E-02	-2.99E-02	-2.35E-02	-1.80E-02	-1.29E-02	-8.13E-03	-3.68E-03	4.77E-04	4.17E-03
6	-3.48E-02	-2.32E-02	-1.69E-02	-1.21E-02	-7.67E-03	-3.37E-03	8.04E-04	4.86E-03	8.77E-03	1.23E-02
7	-1.49E-02	-6.23E-03	-2.67E-03	-1.81E-04	2.20E-03	4.76E-03	7.45E-03	1.02E-02	1.30E-02	1.55E-02
8	1.55E-03	7.40E-03	8.05E-03	7.84E-03	7.76E-03	8.09E-03	8.74E-03	9.65E-03	1.07E-02	1.17E-02
9	1.11E-02	1.44E-02	1.23E-02	9.37E-03	6.73E-03	4.64E-03	3.01E-03	1.77E-03	8.15E-04	-1.05E-04
10	1.20E-02	1.32E-02	8.61E-03	3.22E-03	-1.87E-03	-6.33E-03	-1.03E-02	-1.37E-02	-1.68E-02	-1.97E-02

Low	1	2	3	4	5	6	7	8	9	10
1	6.71E-02	4.95E-02	3.73E-02	2.74E-02	1.92E-02	1.21E-02	5.90E-03	2.93E-04	-4.90E-03	-9.99E-03
2	-3.07E-02	-1.97E-02	-1.38E-02	-1.00E-02	-7.48E-03	-5.50E-03	-3.99E-03	-2.86E-03	-2.09E-03	-1.85E-03
3	-3.74E-02	-2.52E-02	-1.80E-02	-1.27E-02	-8.27E-03	-4.35E-03	-8.56E-04	2.24E-03	4.93E-03	7.02E-03
4	-1.10E-02	-5.66E-03	-3.70E-03	-2.26E-03	-7.60E-04	9.53E-04	2.73E-03	4.51E-03	6.15E-03	7.42E-03
5	1.86E-02	1.57E-02	1.04E-02	5.87E-03	2.30E-03	-3.40E-04	-2.32E-03	-3.85E-03	-5.13E-03	-6.47E-03

High	1	2	3	4	5	6	7	8	9	10
6	6.48E-03	6.52E-03	3.81E-03	1.58E-03	2.26E-04	-3.02E-04	-3.54E-04	-1.90E-04	-5.64E-05	-3.32E-04
7	-3.26E-03	-4.25E-04	-1.28E-03	-2.16E-03	-2.43E-03	-2.07E-03	-1.37E-03	-5.32E-04	1.96E-04	4.49E-04
8	-5.25E-03	-9.22E-04	-1.02E-03	-1.48E-03	-1.54E-03	-1.08E-03	-3.34E-04	4.99E-04	1.19E-03	1.40E-03
9	-3.95E-03	1.15E-03	1.20E-03	5.84E-04	2.29E-04	2.96E-04	5.97E-04	9.55E-04	1.18E-03	9.16E-04
10	-2.38E-03	3.12E-03	2.97E-03	1.88E-03	9.03E-04	2.62E-04	-2.00E-04	-6.19E-04	-1.18E-03	-2.20E-03

2 MeV Al-SS Exposure (Fractional Difference)

Full	1	2	3	4	5	6	7	8	9	10
1	1.98E-01	1.44E-01	1.08E-01	8.06E-02	5.88E-02	4.08E-02	2.55E-02	1.23E-02	8.44E-04	-9.25E-03
2	3.29E-02	2.75E-02	2.16E-02	1.56E-02	9.65E-03	4.00E-03	-1.30E-03	-6.21E-03	-1.07E-02	-1.49E-02
3	-3.70E-02	-2.53E-02	-1.87E-02	-1.49E-02	-1.28E-02	-1.17E-02	-1.12E-02	-1.12E-02	-1.13E-02	-1.17E-02
4	-5.76E-02	-4.16E-02	-3.10E-02	-2.35E-02	-1.79E-02	-1.37E-02	-1.04E-02	-7.69E-03	-5.45E-03	-3.57E-03
5	-5.21E-02	-3.74E-02	-2.71E-02	-1.94E-02	-1.32E-02	-8.20E-03	-4.00E-03	-3.82E-04	2.83E-03	5.67E-03
6	-3.43E-02	-2.33E-02	-1.56E-02	-9.59E-03	-4.60E-03	-3.43E-04	3.39E-03	6.77E-03	9.88E-03	1.27E-02
7	-1.32E-02	-6.85E-03	-2.80E-03	4.24E-04	3.26E-03	5.81E-03	8.24E-03	1.05E-02	1.28E-02	1.50E-02
8	5.12E-03	6.67E-03	6.79E-03	6.81E-03	7.01E-03	7.39E-03	7.97E-03	8.74E-03	9.69E-03	1.07E-02
9	1.70E-02	1.41E-02	1.04E-02	7.23E-03	4.71E-03	2.74E-03	1.29E-03	4.14E-04	-2.37E-04	-5.79E-04
10	2.06E-02	1.39E-02	6.81E-03	6.74E-04	-4.30E-03	-8.54E-03	-1.20E-02	-1.48E-02	-1.71E-02	-1.89E-02

Low	1	2	3	4	5	6	7	8	9	10
1	5.91E-02	4.29E-02	3.18E-02	2.29E-02	1.54E-02	8.85E-03	3.15E-03	-1.84E-03	-6.18E-03	-1.00E-02
2	-2.93E-02	-1.85E-02	-1.21E-02	-8.13E-03	-5.64E-03	-4.04E-03	-2.94E-03	-2.13E-03	-1.47E-03	-9.36E-04
3	-3.50E-02	-2.32E-02	-1.54E-02	-9.90E-03	-5.67E-03	-2.30E-03	5.34E-04	3.01E-03	5.27E-03	7.31E-03
4	-9.42E-03	-5.29E-03	-2.96E-03	-1.25E-03	2.33E-04	1.59E-03	2.93E-03	4.29E-03	5.70E-03	7.12E-03
5	1.97E-02	1.41E-02	8.79E-03	4.51E-03	1.21E-03	-1.34E-03	-3.23E-03	-4.60E-03	-5.49E-03	-6.06E-03

High	1	2	3	4	5	6	7	8	9	10
6	4.93E-03	4.31E-03	3.11E-03	2.19E-03	1.55E-03	1.02E-03	4.97E-04	-1.17E-04	-9.02E-04	-2.01E-03
7	-3.48E-03	-2.36E-03	-2.13E-03	-1.79E-03	-1.28E-03	-7.57E-04	-2.65E-04	4.86E-05	1.40E-04	-1.51E-04
8	-3.93E-03	-2.61E-03	-2.25E-03	-1.77E-03	-1.08E-03	-3.26E-04	3.93E-04	9.72E-04	1.33E-03	1.30E-03
9	-6.70E-04	-3.26E-05	-3.12E-04	-3.80E-04	-1.30E-04	2.59E-04	6.98E-04	1.19E-03	1.33E-03	1.19E-03
10	3.27E-03	2.78E-03	1.41E-03	3.98E-04	-6.17E-05	-3.94E-04	-5.93E-04	-7.97E-04	-1.12E-03	-1.69E-03

6 MeV Al-SS Exposure (Fractional Difference)

Full	1	2	3	4	5	6	7	8	9	10
1	1.33E-01	1.15E-01	9.70E-02	7.87E-02	6.04E-02	4.27E-02	2.62E-02	1.12E-02	-2.08E-03	-1.35E-02
2	1.48E-02	2.51E-02	2.73E-02	2.40E-02	1.76E-02	9.76E-03	1.47E-03	-6.45E-03	-1.35E-02	-1.95E-02
3	-3.91E-02	-1.86E-02	-7.76E-03	-3.55E-03	-3.42E-03	-5.51E-03	-8.65E-03	-1.19E-02	-1.48E-02	-1.69E-02
4	-5.72E-02	-3.45E-02	-2.08E-02	-1.34E-02	-1.01E-02	-9.06E-03	-9.16E-03	-9.53E-03	-9.59E-03	-8.92E-03
5	-5.39E-02	-3.34E-02	-2.02E-02	-1.24E-02	-8.04E-03	-5.67E-03	-4.25E-03	-3.04E-03	-1.23E-03	1.17E-03
6	-3.83E-02	-2.26E-02	-1.21E-02	-5.69E-03	-1.98E-03	5.36E-04	2.29E-03	4.15E-03	6.84E-03	1.03E-02
7	-1.75E-02	-8.26E-03	-1.74E-03	1.97E-03	4.08E-03	5.68E-03	7.01E-03	8.81E-03	1.17E-02	1.56E-02
8	2.51E-03	4.84E-03	6.29E-03	6.68E-03	6.75E-03	6.60E-03	6.93E-03	8.36E-03	1.07E-02	1.48E-02
9	1.74E-02	1.24E-02	8.81E-03	5.60E-03	3.09E-03	1.08E-03	8.91E-05	5.60E-04	2.26E-03	5.80E-03
10	2.38E-02	1.20E-02	3.55E-03	-3.19E-03	-8.32E-03	-1.23E-02	-1.48E-02	-1.54E-02	-1.47E-02	-1.19E-02

Low	1	2	3	4	5	6	7	8	9	10
1	3.93E-02	3.24E-02	2.76E-02	2.22E-02	1.60E-02	9.74E-03	3.57E-03	-2.14E-03	-7.19E-03	-1.15E-02
2	-2.70E-02	-1.62E-02	-8.73E-03	-4.56E-03	-2.63E-03	-2.04E-03	-2.17E-03	-2.49E-03	-2.68E-03	-2.51E-03
3	-3.06E-02	-2.03E-02	-1.24E-02	-7.05E-03	-3.50E-03	-1.05E-03	8.01E-04	2.52E-03	4.38E-03	6.59E-03
4	-7.42E-03	-5.35E-03	-2.76E-03	-8.60E-04	4.56E-04	1.52E-03	2.57E-03	3.90E-03	5.66E-03	8.00E-03
5	2.07E-02	1.18E-02	6.44E-03	2.55E-03	-4.81E-04	-2.72E-03	-4.22E-03	-4.96E-03	-4.65E-03	-3.67E-03

High	1	2	3	4	5	6	7	8	9	10
6	1.60E-03	2.16E-03	3.50E-03	4.12E-03	3.79E-03	3.02E-03	1.54E-03	-2.30E-04	-1.92E-03	-3.85E-03
7	-4.58E-03	-4.01E-03	-1.99E-03	-5.74E-04	1.87E-04	6.04E-04	3.71E-04	-1.40E-04	-5.69E-04	-1.26E-03
8	-3.48E-03	-4.00E-03	-2.80E-03	-1.52E-03	-3.39E-04	2.63E-04	5.86E-04	9.55E-04	1.01E-03	1.30E-03
9	1.60E-03	-1.14E-03	-1.36E-03	-9.41E-04	-2.26E-04	1.91E-04	5.37E-04	1.07E-03	1.41E-03	2.04E-03
10	7.84E-03	2.28E-03	8.62E-05	-8.73E-04	-1.11E-03	-1.32E-03	-1.37E-03	-1.05E-03	-7.99E-04	-1.29E-04

10 MeV Al-SS Exposure (Fractional Difference)

Full	1	2	3	4	5	6	7	8	9	10
1	9.58E-02	9.25E-02	8.61E-02	7.57E-02	6.26E-02	4.81E-02	3.33E-02	1.91E-02	5.88E-03	-5.81E-03
2	4.93E-03	1.95E-02	2.58E-02	2.53E-02	2.06E-02	1.33E-02	5.02E-03	-3.45E-03	-1.13E-02	-1.80E-02
3	-3.75E-02	-1.66E-02	-4.97E-03	-5.00E-04	-6.91E-04	-3.62E-03	-7.86E-03	-1.24E-02	-1.65E-02	-1.94E-02
4	-5.21E-02	-3.01E-02	-1.68E-02	-1.02E-02	-8.15E-03	-8.63E-03	-1.03E-02	-1.22E-02	-1.36E-02	-1.37E-02
5	-4.94E-02	-2.92E-02	-1.65E-02	-9.74E-03	-6.94E-03	-6.23E-03	-6.44E-03	-6.58E-03	-6.14E-03	-4.04E-03
6	-3.61E-02	-1.97E-02	-9.40E-03	-3.76E-03	-1.25E-03	-3.67E-04	4.12E-05	6.51E-04	2.61E-03	6.31E-03
7	-1.81E-02	-6.93E-03	3.40E-05	3.55E-03	4.84E-03	5.16E-03	5.52E-03	6.51E-03	9.21E-03	1.40E-02
8	-3.01E-04	4.70E-03	7.50E-03	8.23E-03	7.69E-03	6.90E-03	6.70E-03	7.57E-03	1.05E-02	1.59E-02
9	1.27E-02	1.11E-02	9.29E-03	6.85E-03	4.13E-03	1.87E-03	7.33E-04	1.07E-03	3.82E-03	9.25E-03
10	1.71E-02	8.87E-03	2.51E-03	-3.18E-03	-8.22E-03	-1.21E-02	-1.44E-02	-1.49E-02	-1.28E-02	-7.73E-03

Low	1	2	3	4	5	6	7	8	9	10
1	2.77E-02	2.52E-02	2.43E-02	2.15E-02	1.71E-02	1.15E-02	5.46E-03	-6.14E-04	-6.21E-03	-1.10E-02
2	-2.42E-02	-1.45E-02	-6.93E-03	-2.69E-03	-1.01E-03	-1.01E-03	-1.90E-03	-3.07E-03	-3.96E-03	-4.18E-03
3	-2.69E-02	-1.81E-02	-1.05E-02	-5.55E-03	-2.58E-03	-8.87E-04	2.08E-04	1.25E-03	2.76E-03	5.12E-03
4	-6.91E-03	-5.26E-03	-2.40E-03	-4.44E-04	6.58E-04	1.33E-03	2.03E-03	3.16E-03	5.05E-03	8.23E-03
5	1.86E-02	1.00E-02	5.56E-03	2.18E-03	-6.82E-04	-2.87E-03	-4.28E-03	-4.67E-03	-4.01E-03	-1.64E-03

High	1	2	3	4	5	6	7	8	9	10
6	-6.09E-05	7.85E-04	2.98E-03	4.43E-03	4.66E-03	3.88E-03	2.39E-03	2.68E-04	-1.78E-03	-3.75E-03
7	-4.74E-03	-4.45E-03	-2.21E-03	-2.99E-04	6.95E-04	8.91E-04	5.28E-04	-3.45E-04	-1.06E-03	-1.62E-03
8	-2.97E-03	-4.26E-03	-2.86E-03	-1.27E-03	-2.08E-04	3.40E-04	5.48E-04	4.11E-04	5.61E-04	9.87E-04
9	2.34E-03	-1.30E-03	-1.44E-03	-7.67E-04	-1.99E-04	1.87E-04	4.87E-04	6.39E-04	1.25E-03	2.27E-03
10	8.69E-03	2.10E-03	-8.96E-05	-8.41E-04	-1.22E-03	-1.43E-03	-1.45E-03	-1.40E-03	-7.03E-04	5.48E-04

Stainless Steel followed by Aluminum

65 keV SS-Al Exposure (Fractional Difference)

Full	1	2	3	4	5	6	7	8	9	10
1	2.30E-02	2.88E-02	3.67E-02	3.92E-02	3.63E-02	2.95E-02	2.00E-02	9.11E-03	-2.48E-03	-1.39E-02
2	-1.44E-02	-2.45E-03	1.03E-02	1.71E-02	1.84E-02	1.54E-02	9.69E-03	2.39E-03	-5.64E-03	-1.36E-02
3	-3.29E-02	-2.01E-02	-5.67E-03	3.32E-03	7.03E-03	6.75E-03	3.79E-03	-6.46E-04	-5.73E-03	-1.06E-02
4	-3.85E-02	-2.81E-02	-1.41E-02	-4.49E-03	5.18E-04	1.97E-03	1.06E-03	-1.13E-03	-3.77E-03	-5.99E-03
5	-3.46E-02	-2.90E-02	-1.70E-02	-7.90E-03	-2.55E-03	-1.65E-04	2.59E-04	-2.52E-04	-9.22E-04	-8.99E-04
6	-2.34E-02	-2.44E-02	-1.57E-02	-8.19E-03	-3.33E-03	-7.30E-04	4.72E-04	1.11E-03	1.94E-03	3.80E-03
7	-6.72E-03	-1.59E-02	-1.16E-02	-6.52E-03	-2.88E-03	-6.74E-04	6.48E-04	1.91E-03	3.76E-03	7.01E-03
8	1.37E-02	-4.80E-03	-5.83E-03	-3.92E-03	-2.17E-03	-1.01E-03	-6.97E-05	1.31E-03	3.68E-03	7.83E-03
9	3.66E-02	7.75E-03	6.65E-04	-1.27E-03	-2.00E-03	-2.43E-03	-2.34E-03	-1.36E-03	1.04E-03	5.56E-03
10	6.04E-02	2.05E-02	6.78E-03	4.56E-04	-3.28E-03	-5.73E-03	-7.09E-03	-7.00E-03	-5.11E-03	-7.58E-04

Low	1	2	3	4	5	6	7	8	9	10
1	4.09E-03	3.14E-03	9.48E-03	1.33E-02	1.36E-02	1.11E-02	6.93E-03	1.99E-03	-3.03E-03	-7.37E-03
2	-1.71E-02	-1.57E-02	-7.00E-03	-6.05E-04	2.51E-03	3.03E-03	1.94E-03	1.91E-04	-1.49E-03	-2.32E-03
3	-1.37E-02	-1.76E-02	-1.11E-02	-5.31E-03	-1.84E-03	-3.16E-04	4.49E-05	1.23E-04	5.81E-04	2.22E-03
4	6.31E-03	-7.75E-03	-6.76E-03	-4.06E-03	-2.22E-03	-1.33E-03	-9.03E-04	-2.61E-04	1.19E-03	4.20E-03
5	3.77E-02	9.87E-03	2.84E-03	5.06E-04	-9.10E-04	-2.11E-03	-2.95E-03	-2.95E-03	-1.66E-03	1.60E-03

High	1	2	3	4	5	6	7	8	9	10
6	-9.66E-03	-8.93E-03	-7.06E-04	5.10E-03	7.40E-03	6.90E-03	4.61E-03	1.49E-03	-1.69E-03	-4.05E-03
7	-6.55E-03	-1.03E-02	-4.09E-03	9.71E-04	3.36E-03	3.50E-03	2.18E-03	3.81E-04	-1.19E-03	-1.68E-03
8	9.69E-04	-8.23E-03	-4.82E-03	-1.08E-03	8.93E-04	1.20E-03	5.29E-04	-2.70E-04	-5.18E-04	6.15E-04
9	1.20E-02	-3.57E-03	-3.56E-03	-1.65E-03	-5.49E-04	-4.67E-04	-7.91E-04	-9.10E-04	-1.26E-04	2.36E-03
10	2.54E-02	2.82E-03	-1.13E-03	-1.53E-03	-1.70E-03	-2.15E-03	-2.58E-03	-2.32E-03	-8.23E-04	2.72E-03

100 keV SS-Al Exposure (Fractional Difference)

Full	1	2	3	4	5	6	7	8	9	10
1	3.01E-02	6.24E-02	7.84E-02	8.15E-02	7.56E-02	6.35E-02	4.72E-02	2.81E-02	6.91E-03	-1.58E-02
2	-4.93E-02	-4.66E-03	2.13E-02	3.32E-02	3.54E-02	3.09E-02	2.17E-02	9.07E-03	-5.95E-03	-2.29E-02
3	-8.25E-02	-3.89E-02	-1.07E-02	4.85E-03	1.15E-02	1.18E-02	7.46E-03	-1.75E-04	-1.03E-02	-2.24E-02
4	-8.79E-02	-5.23E-02	-2.63E-02	-1.02E-02	-1.51E-03	1.68E-03	8.68E-04	-2.93E-03	-9.02E-03	-1.70E-02
5	-7.48E-02	-5.12E-02	-3.04E-02	-1.58E-02	-6.77E-03	-2.02E-03	-4.79E-04	-1.38E-03	-4.15E-03	-8.55E-03
6	-4.92E-02	-4.04E-02	-2.66E-02	-1.52E-02	-7.26E-03	-2.10E-03	8.23E-04	2.03E-03	1.90E-03	5.60E-04
7	-1.53E-02	-2.33E-02	-1.80E-02	-1.13E-02	-5.45E-03	-9.16E-04	2.51E-03	5.03E-03	6.85E-03	7.99E-03
8	2.33E-02	-2.94E-03	-7.45E-03	-6.35E-03	-3.67E-03	-6.65E-04	2.39E-03	5.37E-03	8.37E-03	1.13E-02
9	6.30E-02	1.79E-02	2.82E-03	-2.54E-03	-3.93E-03	-3.32E-03	-1.52E-03	1.12E-03	4.44E-03	8.22E-03
10	1.01E-01	3.68E-02	1.06E-02	-1.84E-03	-7.92E-03	-1.05E-02	-1.08E-02	-9.45E-03	-6.77E-03	-3.10E-03

Low	1	2	3	4	5	6	7	8	9	10
1	-5.34E-03	9.68E-03	2.12E-02	2.61E-02	2.58E-02	2.17E-02	1.52E-02	6.91E-03	-2.50E-03	-1.28E-02
2	-4.75E-02	-2.88E-02	-1.29E-02	-2.85E-03	2.29E-03	3.98E-03	3.29E-03	9.88E-04	-2.36E-03	-6.49E-03
3	-3.50E-02	-2.99E-02	-1.94E-02	-1.12E-02	-5.59E-03	-2.14E-03	-1.38E-04	9.40E-04	1.52E-03	1.74E-03
4	9.15E-03	-8.50E-03	-9.76E-03	-7.84E-03	-5.51E-03	-3.36E-03	-1.29E-03	8.78E-04	3.31E-03	6.03E-03
5	7.08E-02	2.50E-02	8.15E-03	5.88E-04	-3.08E-03	-4.69E-03	-4.85E-03	-3.81E-03	-1.63E-03	1.54E-03

High	1	2	3	4	5	6	7	8	9	10
6	-3.27E-02	-1.61E-02	-1.16E-03	7.82E-03	1.16E-02	1.15E-02	8.79E-03	4.30E-03	-1.22E-03	-7.36E-03
7	-2.15E-02	-1.60E-02	-6.04E-03	9.31E-04	4.43E-03	5.20E-03	4.10E-03	1.81E-03	-1.06E-03	-4.17E-03
8	-3.24E-03	-1.01E-02	-6.28E-03	-2.25E-03	2.50E-04	1.22E-03	1.20E-03	6.05E-04	-5.98E-06	-3.54E-04
9	1.97E-02	-5.30E-04	-3.58E-03	-3.16E-03	-2.38E-03	-1.77E-03	-1.25E-03	-5.35E-04	7.15E-04	2.70E-03
10	4.51E-02	1.10E-02	4.84E-04	-3.33E-03	-4.73E-03	-5.04E-03	-4.47E-03	-2.97E-03	-3.23E-04	3.61E-03

500 keV SS-Al Exposure (Fractional Difference)

Full	1	2	3	4	5	6	7	8	9	10
1	1.85E-01	1.85E-01	1.73E-01	1.54E-01	1.31E-01	1.06E-01	7.94E-02	5.16E-02	2.29E-02	-6.77E-03
2	5.26E-03	3.49E-02	4.83E-02	5.13E-02	4.74E-02	3.87E-02	2.64E-02	1.11E-02	-6.82E-03	-2.72E-02
3	-6.71E-02	-3.59E-02	-1.55E-02	-3.62E-03	1.92E-03	2.56E-03	-8.99E-04	-7.98E-03	-1.84E-02	-3.22E-02
4	-8.45E-02	-6.12E-02	-4.20E-02	-2.77E-02	-1.79E-02	-1.22E-02	-1.02E-02	-1.19E-02	-1.71E-02	-2.61E-02
5	-7.16E-02	-5.99E-02	-4.54E-02	-3.21E-02	-2.12E-02	-1.31E-02	-8.04E-03	-6.25E-03	-7.99E-03	-1.36E-02
6	-4.28E-02	-4.38E-02	-3.58E-02	-2.55E-02	-1.54E-02	-6.74E-03	-2.29E-04	3.52E-03	3.98E-03	5.99E-04
7	-7.96E-03	-2.17E-02	-2.09E-02	-1.47E-02	-6.73E-03	1.18E-03	7.82E-03	1.23E-02	1.38E-02	1.16E-02
8	2.57E-02	-8.86E-05	-6.83E-03	-5.43E-03	-5.18E-04	5.55E-03	1.12E-02	1.52E-02	1.66E-02	1.47E-02
9	5.29E-02	1.59E-02	1.71E-03	-2.09E-03	-9.20E-04	2.41E-03	6.04E-03	8.62E-03	9.08E-03	6.42E-03
10	7.00E-02	2.28E-02	1.52E-03	-7.65E-03	-1.07E-02	-1.08E-02	-9.92E-03	-9.60E-03	-1.10E-02	-1.51E-02

Low	1	2	3	4	5	6	7	8	9	10
1	2.61E-02	4.24E-02	4.70E-02	4.48E-02	3.86E-02	3.02E-02	2.02E-02	8.87E-03	-3.73E-03	-1.78E-02
2	-5.67E-02	-3.27E-02	-1.75E-02	-8.15E-03	-2.75E-03	-8.24E-05	4.06E-04	-1.06E-03	-4.52E-03	-1.03E-02
3	-4.44E-02	-3.62E-02	-2.68E-02	-1.84E-02	-1.13E-02	-5.37E-03	-7.29E-04	2.41E-03	3.73E-03	2.74E-03
4	5.36E-03	-8.64E-03	-1.16E-02	-1.01E-02	-6.66E-03	-2.36E-03	1.97E-03	5.67E-03	8.14E-03	8.66E-03
5	6.12E-02	2.45E-02	7.25E-03	-8.71E-04	-4.11E-03	-4.62E-03	-3.78E-03	-2.63E-03	-2.04E-03	-2.86E-03

High	1	2	3	4	5	6	7	8	9	10
6	-1.89E-02	-5.48E-03	5.04E-03	1.10E-02	1.30E-02	1.19E-02	8.48E-03	3.48E-03	-2.64E-03	-9.55E-03
7	-1.65E-02	-1.17E-02	-4.77E-03	4.66E-04	3.35E-03	4.16E-03	3.29E-03	1.15E-03	-1.92E-03	-5.70E-03
8	-4.27E-03	-8.91E-03	-6.59E-03	-3.28E-03	-6.42E-04	1.00E-03	1.65E-03	1.48E-03	6.82E-04	-6.39E-04
9	1.26E-02	-1.69E-03	-4.63E-03	-4.02E-03	-2.46E-03	-8.31E-04	5.44E-04	1.60E-03	2.39E-03	2.89E-03
10	2.99E-02	6.00E-03	-2.49E-03	-5.10E-03	-5.25E-03	-4.30E-03	-2.89E-03	-1.28E-03	4.44E-04	2.16E-03

1 MeV SS-Al Exposure (Fractional Difference)

Full	1	2	3	4	5	6	7	8	9	10
1	8.41E-01	4.48E-01	2.18E-01	7.37E-02	-1.75E-02	-6.97E-02	-8.39E-02	2.81E-02	-1.62E-01	-6.27E-02
2	4.42E-01	2.02E-01	5.41E-02	-4.05E-02	-9.85E-02	-1.28E-01	-1.30E-01	-1.04E-01	-6.91E-03	4.33E-02
3	2.54E-01	9.10E-02	-8.98E-03	-6.93E-02	-9.99E-02	-1.05E-01	-8.41E-02	-3.75E-02	2.46E-02	-4.14E-02
4	1.61E-01	4.29E-02	-2.61E-02	-6.31E-02	-7.49E-02	-6.43E-02	-3.35E-02	1.24E-02	5.25E-02	2.04E-02
5	1.13E-01	2.40E-02	-2.45E-02	-4.61E-02	-4.65E-02	-2.90E-02	2.52E-03	3.93E-02	6.11E-02	2.84E-02
6	8.80E-02	1.75E-02	-1.75E-02	-2.95E-02	-2.40E-02	-5.05E-03	2.22E-02	4.83E-02	5.63E-02	2.13E-02
7	7.26E-02	1.47E-02	-1.15E-02	-1.80E-02	-1.03E-02	6.94E-03	2.81E-02	4.44E-02	4.24E-02	5.86E-03
8	6.09E-02	1.16E-02	-9.09E-03	-1.28E-02	-5.34E-03	8.70E-03	2.36E-02	3.16E-02	2.25E-02	-1.46E-02
9	4.98E-02	6.23E-03	-1.11E-02	-1.39E-02	-7.84E-03	2.42E-03	1.16E-02	1.30E-02	-1.03E-03	-3.80E-02
10	3.77E-02	-2.02E-03	-1.76E-02	-2.06E-02	-1.65E-02	-1.00E-02	-5.85E-03	-9.50E-03	-2.69E-02	-6.33E-02

Low	1	2	3	4	5	6	7	8	9	10
1	5.40E-02	4.84E-02	4.18E-02	3.40E-02	2.59E-02	1.77E-02	9.80E-03	1.99E-03	-5.81E-03	-1.38E-02
2	-3.92E-02	-2.44E-02	-1.46E-02	-8.63E-03	-5.01E-03	-2.97E-03	-2.08E-03	-2.12E-03	-3.05E-03	-4.94E-03
3	-3.84E-02	-3.01E-02	-2.15E-02	-1.44E-02	-8.52E-03	-3.77E-03	2.13E-05	2.89E-03	4.79E-03	5.60E-03
4	-2.31E-03	-8.37E-03	-7.93E-03	-5.59E-03	-2.67E-03	3.09E-04	3.07E-03	5.40E-03	7.09E-03	7.91E-03
5	3.78E-02	1.63E-02	6.56E-03	1.63E-03	-9.06E-04	-2.18E-03	-2.81E-03	-3.25E-03	-3.86E-03	-4.95E-03

High	1	2	3	4	5	6	7	8	9	10
6	-2.04E-03	3.77E-04	4.46E-03	6.82E-03	7.21E-03	6.02E-03	3.75E-03	7.89E-04	-2.53E-03	-6.02E-03
7	-6.84E-03	-7.27E-03	-3.67E-03	-5.87E-04	1.19E-03	1.72E-03	1.32E-03	2.82E-04	-1.12E-03	-2.73E-03
8	-2.20E-03	-6.84E-03	-5.08E-03	-2.55E-03	-5.67E-04	6.33E-04	1.18E-03	1.24E-03	1.03E-03	6.66E-04
9	6.84E-03	-2.62E-03	-3.49E-03	-2.32E-03	-9.28E-04	1.93E-04	9.80E-04	1.52E-03	1.92E-03	2.27E-03
10	1.63E-02	1.87E-03	-2.02E-03	-2.71E-03	-2.42E-03	-1.91E-03	-1.38E-03	-8.58E-04	-2.88E-04	3.45E-04

2 MeV SS-Al Exposure (Fractional Difference)

Full	1	2	3	4	5	6	7	8	9	10
1	1.95E-01	1.39E-01	1.03E-01	7.69E-02	5.64E-02	3.96E-02	2.54E-02	1.31E-02	2.13E-03	-7.77E-03
2	3.01E-02	2.29E-02	1.75E-02	1.25E-02	7.68E-03	3.10E-03	-1.30E-03	-5.60E-03	-9.84E-03	-1.41E-02
3	-3.68E-02	-2.83E-02	-2.16E-02	-1.70E-02	-1.40E-02	-1.20E-02	-1.10E-02	-1.06E-02	-1.08E-02	-1.16E-02
4	-5.42E-02	-4.26E-02	-3.24E-02	-2.44E-02	-1.83E-02	-1.35E-02	-9.80E-03	-7.07E-03	-5.18E-03	-4.06E-03
5	-4.63E-02	-3.69E-02	-2.74E-02	-1.94E-02	-1.28E-02	-7.49E-03	-3.15E-03	2.78E-04	2.88E-03	4.74E-03
6	-2.72E-02	-2.22E-02	-1.54E-02	-9.24E-03	-3.91E-03	5.97E-04	4.35E-03	7.38E-03	9.72E-03	1.14E-02
7	-6.20E-03	-6.22E-03	-2.95E-03	6.00E-04	3.87E-03	6.73E-03	9.15E-03	1.11E-02	1.25E-02	1.35E-02
8	1.08E-02	6.03E-03	5.68E-03	6.34E-03	7.23E-03	8.08E-03	8.81E-03	9.31E-03	9.58E-03	9.44E-03
9	2.06E-02	1.16E-02	7.94E-03	5.83E-03	4.34E-03	3.16E-03	2.11E-03	1.06E-03	-4.83E-05	-1.36E-03
10	2.17E-02	9.24E-03	2.75E-03	-1.80E-03	-5.42E-03	-8.50E-03	-1.12E-02	-1.38E-02	-1.62E-02	-1.87E-02

Low	1	2	3	4	5	6	7	8	9	10
1	5.67E-02	4.16E-02	3.10E-02	2.24E-02	1.50E-02	8.57E-03	2.99E-03	-1.90E-03	-6.20E-03	-1.00E-02
2	-2.97E-02	-1.91E-02	-1.22E-02	-7.94E-03	-5.33E-03	-3.69E-03	-2.61E-03	-1.89E-03	-1.39E-03	-1.07E-03
3	-3.32E-02	-2.32E-02	-1.53E-02	-9.55E-03	-5.21E-03	-1.82E-03	9.44E-04	3.25E-03	5.25E-03	6.96E-03
4	-6.43E-03	-5.58E-03	-3.34E-03	-1.34E-03	3.40E-04	1.82E-03	3.18E-03	4.45E-03	5.65E-03	6.78E-03
5	2.22E-02	1.24E-02	7.14E-03	3.41E-03	5.92E-04	-1.56E-03	-3.17E-03	-4.39E-03	-5.28E-03	-5.89E-03

High	1	2	3	4	5	6	7	8	9	10
6	3.46E-03	2.05E-03	2.62E-03	2.89E-03	2.62E-03	1.95E-03	1.02E-03	-1.04E-04	-1.34E-03	-2.60E-03
7	-2.89E-03	-3.96E-03	-2.52E-03	-1.22E-03	-3.85E-04	2.86E-05	1.40E-04	1.58E-05	-2.72E-04	-6.54E-04
8	-1.82E-03	-3.90E-03	-2.80E-03	-1.50E-03	-4.79E-04	2.16E-04	6.82E-04	9.38E-04	1.10E-03	1.07E-03
9	2.34E-03	-1.39E-03	-1.26E-03	-5.73E-04	5.42E-05	5.37E-04	8.86E-04	1.10E-03	1.26E-03	1.28E-03
10	6.48E-03	8.69E-04	-2.69E-04	-5.01E-04	-5.71E-04	-6.16E-04	-6.73E-04	-7.71E-04	-8.53E-04	-1.01E-03

6 MeV SS-Al Exposure (Fractional Difference)

Full	1	2	3	4	5	6	7	8	9	10
1	1.05E-01	7.79E-02	5.74E-02	4.11E-02	2.79E-02	1.74E-02	9.46E-03	3.83E-03	4.70E-04	-6.80E-04
2	4.04E-03	8.49E-03	6.93E-03	3.36E-03	-5.19E-04	-3.87E-03	-6.19E-03	-7.08E-03	-6.51E-03	-4.29E-03
3	-3.53E-02	-2.01E-02	-1.42E-02	-1.22E-02	-1.17E-02	-1.16E-02	-1.09E-02	-9.43E-03	-6.70E-03	-2.57E-03
4	-4.18E-02	-2.46E-02	-1.70E-02	-1.36E-02	-1.19E-02	-1.06E-02	-8.95E-03	-6.51E-03	-2.93E-03	1.98E-03
5	-3.23E-02	-1.67E-02	-1.02E-02	-7.45E-03	-6.20E-03	-5.22E-03	-3.78E-03	-1.37E-03	2.15E-03	7.04E-03
6	-1.75E-02	-4.69E-03	-1.88E-04	9.79E-04	9.88E-04	1.00E-03	1.62E-03	3.25E-03	6.16E-03	1.05E-02
7	-4.39E-03	5.83E-03	8.31E-03	7.81E-03	6.40E-03	5.17E-03	4.71E-03	5.39E-03	7.41E-03	1.09E-02
8	2.99E-03	1.14E-02	1.24E-02	1.06E-02	7.92E-03	5.58E-03	4.09E-03	3.85E-03	4.93E-03	7.53E-03
9	2.83E-03	1.04E-02	1.06E-02	7.93E-03	4.52E-03	1.36E-03	-9.62E-04	-2.11E-03	-1.88E-03	-1.77E-04
10	-5.15E-03	2.36E-03	2.45E-03	-4.30E-04	-4.21E-03	-7.82E-03	-1.07E-02	-1.24E-02	-1.29E-02	-1.19E-02

Low	1	2	3	4	5	6	7	8	9	10
1	4.08E-02	2.57E-02	1.64E-02	9.91E-03	5.01E-03	1.30E-03	-1.42E-03	-3.24E-03	-4.20E-03	-4.35E-03
2	-1.92E-02	-1.14E-02	-7.78E-03	-5.88E-03	-4.71E-03	-3.77E-03	-2.78E-03	-1.46E-03	1.58E-04	2.22E-03
3	-2.40E-02	-1.25E-02	-7.11E-03	-4.17E-03	-2.31E-03	-8.36E-04	6.34E-04	2.27E-03	4.24E-03	6.62E-03
4	-9.23E-03	-6.59E-04	1.97E-03	2.48E-03	2.29E-03	2.02E-03	2.00E-03	2.39E-03	3.27E-03	4.71E-03
5	4.90E-03	9.20E-03	7.99E-03	5.11E-03	1.96E-03	-8.96E-04	-3.17E-03	-4.70E-03	-5.56E-03	-5.69E-03

High	1	2	3	4	5	6	7	8	9	10
6	8.02E-04	3.99E-03	2.56E-03	2.46E-04	-1.67E-03	-2.68E-03	-2.65E-03	-1.49E-03	7.83E-04	4.14E-03
7	-3.23E-03	2.07E-03	1.92E-03	2.27E-04	-1.50E-03	-2.62E-03	-2.88E-03	-2.14E-03	-3.88E-04	2.38E-03
8	-4.60E-03	2.40E-03	3.24E-03	1.99E-03	2.79E-04	-1.08E-03	-1.76E-03	-1.50E-03	-3.90E-04	1.67E-03
9	-6.12E-03	2.50E-03	4.32E-03	3.53E-03	1.95E-03	3.97E-04	-6.65E-04	-1.01E-03	-5.32E-04	8.06E-04
10	-9.41E-03	8.55E-04	3.78E-03	3.59E-03	2.22E-03	6.18E-04	-7.07E-04	-1.41E-03	-1.49E-03	-7.90E-04

10 MeV SS-Al Exposure (Fractional Difference)

Full	1	2	3	4	5	6	7	8	9	10
1	6.82E-02	5.97E-02	4.71E-02	3.41E-02	2.22E-02	1.24E-02	5.21E-03	1.02E-03	4.44E-05	2.37E-03
2	-7.66E-03	7.99E-03	9.36E-03	5.54E-03	3.46E-04	-4.27E-03	-7.27E-03	-7.97E-03	-5.95E-03	-9.73E-04
3	-3.68E-02	-1.33E-02	-6.58E-03	-6.47E-03	-8.59E-03	-1.07E-02	-1.16E-02	-1.04E-02	-6.69E-03	-1.57E-04
4	-4.00E-02	-1.58E-02	-8.37E-03	-7.50E-03	-8.87E-03	-1.03E-02	-1.04E-02	-8.47E-03	-4.06E-03	3.15E-03
5	-3.03E-02	-8.52E-03	-2.46E-03	-2.47E-03	-4.38E-03	-6.04E-03	-6.32E-03	-4.50E-03	-1.02E-04	7.15E-03
6	-1.70E-02	1.89E-03	5.94E-03	4.50E-03	1.54E-03	-9.35E-04	-1.84E-03	-5.30E-04	3.43E-03	1.03E-02
7	-5.97E-03	1.05E-02	1.29E-02	1.01E-02	6.13E-03	2.79E-03	1.12E-03	1.75E-03	5.06E-03	1.13E-02
8	-1.10E-03	1.41E-02	1.55E-02	1.21E-02	7.41E-03	3.36E-03	1.06E-03	1.04E-03	3.68E-03	9.21E-03
9	-4.12E-03	1.10E-02	1.25E-02	8.98E-03	4.17E-03	-8.81E-05	-2.76E-03	-3.26E-03	-1.20E-03	3.64E-03
10	-1.54E-02	7.93E-04	3.24E-03	4.02E-04	-3.99E-03	-8.08E-03	-1.08E-02	-1.15E-02	-9.87E-03	-5.62E-03

Low	1	2	3	4	5	6	7	8	9	10
1	3.47E-02	2.12E-02	1.23E-02	6.17E-03	1.77E-03	-1.24E-03	-2.98E-03	-3.52E-03	-2.84E-03	-1.04E-03
2	-1.53E-02	-7.46E-03	-5.38E-03	-4.92E-03	-4.83E-03	-4.50E-03	-3.66E-03	-2.09E-03	3.63E-04	3.69E-03
3	-2.16E-02	-7.89E-03	-3.41E-03	-1.98E-03	-1.54E-03	-1.21E-03	-4.30E-04	1.03E-03	3.33E-03	6.52E-03
4	-1.25E-02	1.49E-03	4.82E-03	4.60E-03	3.29E-03	1.95E-03	1.16E-03	1.18E-03	2.15E-03	4.09E-03
5	-4.67E-03	8.18E-03	9.58E-03	7.10E-03	3.49E-03	-2.73E-05	-2.91E-03	-4.86E-03	-5.75E-03	-5.58E-03

High	1	2	3	4	5	6	7	8	9	10
6	-8.09E-03	5.84E-03	6.80E-03	3.51E-03	-5.22E-04	-3.61E-03	-4.85E-03	-3.74E-03	7.82E-05	6.79E-03
7	-8.85E-03	5.47E-03	6.69E-03	3.46E-03	-6.69E-04	-3.98E-03	-5.55E-03	-4.84E-03	-1.50E-03	4.66E-03
8	-8.77E-03	6.26E-03	7.97E-03	4.93E-03	7.81E-04	-2.80E-03	-4.71E-03	-4.45E-03	-1.66E-03	3.86E-03
9	-1.03E-02	5.97E-03	8.59E-03	6.07E-03	2.13E-03	-1.41E-03	-3.53E-03	-3.65E-03	-1.36E-03	3.52E-03
10	-1.48E-02	3.21E-03	7.24E-03	5.68E-03	2.31E-03	-9.76E-04	-3.10E-03	-3.42E-03	-1.52E-03	2.82E-03

Polyethylene Followed by Stainless Steel

65 keV Poly-SS Exposure (Fractional Difference)

Full	1	2	3	4	5	6	7	8	9	10
1	1.30E-01	1.18E-01	8.56E-02	5.88E-02	4.02E-02	3.00E-02	2.76E-02	3.32E-02	4.71E-02	6.99E-02
2	-9.07E-05	3.92E-02	2.81E-02	1.34E-02	2.02E-03	-2.48E-03	-8.15E-04	8.14E-03	2.57E-02	5.15E-02
3	-5.79E-02	2.87E-03	-3.10E-04	-1.08E-02	-1.92E-02	-2.14E-02	-1.78E-02	-6.91E-03	1.26E-02	4.06E-02
4	-7.25E-02	-5.22E-03	-8.36E-03	-1.93E-02	-2.79E-02	-3.00E-02	-2.60E-02	-1.45E-02	5.93E-03	3.52E-02
5	-6.05E-02	4.43E-03	-3.23E-03	-1.73E-02	-2.80E-02	-3.14E-02	-2.81E-02	-1.70E-02	3.60E-03	3.34E-02
6	-3.48E-02	2.30E-02	8.67E-03	-9.86E-03	-2.35E-02	-2.89E-02	-2.70E-02	-1.67E-02	3.46E-03	3.33E-02
7	-7.08E-03	4.22E-02	2.14E-02	-1.42E-03	-1.81E-02	-2.56E-02	-2.52E-02	-1.60E-02	3.42E-03	3.29E-02
8	1.10E-02	5.46E-02	2.96E-02	3.88E-03	-1.49E-02	-2.42E-02	-2.52E-02	-1.71E-02	1.48E-03	3.03E-02
9	8.65E-03	5.37E-02	2.89E-02	2.57E-03	-1.70E-02	-2.71E-02	-2.90E-02	-2.18E-02	-4.11E-03	2.39E-02
10	-2.14E-02	3.52E-02	1.59E-02	-7.88E-03	-2.64E-02	-3.63E-02	-3.84E-02	-3.16E-02	-1.47E-02	1.23E-02

Low	1	2	3	4	5	6	7	8	9	10
1	-3.29E-03	2.48E-02	1.86E-02	7.51E-03	-1.94E-03	-7.67E-03	-9.02E-03	-5.44E-03	3.60E-03	1.85E-02
2	-4.37E-02	1.04E-02	1.04E-02	2.36E-03	-5.76E-03	-9.77E-03	-9.92E-03	-4.97E-03	6.30E-03	2.32E-02
3	-3.33E-02	2.15E-02	1.70E-02	5.65E-03	-4.45E-03	-9.47E-03	-9.96E-03	-4.79E-03	7.16E-03	2.52E-02
4	-8.68E-03	3.70E-02	2.41E-02	7.53E-03	-5.79E-03	-1.28E-02	-1.44E-02	-9.81E-03	2.02E-03	2.03E-02
5	-6.72E-03	3.51E-02	1.77E-02	-1.95E-03	-1.73E-02	-2.56E-02	-2.82E-02	-2.43E-02	-1.29E-02	5.03E-03

High	1	2	3	4	5	6	7	8	9	10
6	-5.67E-03	-1.37E-02	-1.08E-02	-5.10E-03	8.78E-04	8.87E-03	1.80E-02	2.98E-02	4.54E-02	6.42E-02
7	1.04E-03	-2.32E-03	-8.66E-03	-1.11E-02	-1.14E-02	-8.33E-03	-3.11E-03	5.27E-03	1.79E-02	3.40E-02
8	1.12E-03	1.01E-02	-1.01E-03	-9.52E-03	-1.52E-02	-1.66E-02	-1.52E-02	-1.01E-02	-4.22E-04	1.29E-02
9	-2.40E-03	2.22E-02	9.46E-03	-3.28E-03	-1.33E-02	-1.86E-02	-2.07E-02	-1.87E-02	-1.19E-02	-1.29E-03
10	-7.03E-03	3.36E-02	2.13E-02	5.79E-03	-7.60E-03	-1.62E-02	-2.14E-02	-2.23E-02	-1.82E-02	-1.00E-02

100 keV Poly-SS Exposure (Fractional Difference)

Full	1	2	3	4	5	6	7	8	9	10
1	9.91E-02	1.18E-01	1.00E-01	7.48E-02	5.01E-02	2.95E-02	1.41E-02	4.76E-03	2.12E-03	7.01E-03
2	-2.20E-02	3.88E-02	4.31E-02	3.18E-02	1.76E-02	4.54E-03	-4.39E-03	-8.20E-03	-6.09E-03	3.62E-03
3	-7.27E-02	1.75E-03	1.38E-02	8.58E-03	-6.28E-04	-9.28E-03	-1.43E-02	-1.47E-02	-8.70E-03	4.81E-03
4	-8.24E-02	-7.91E-03	3.68E-03	-7.33E-04	-8.38E-03	-1.51E-02	-1.79E-02	-1.57E-02	-7.31E-03	9.20E-03
5	-6.73E-02	-4.60E-04	5.85E-03	-9.46E-04	-9.26E-03	-1.56E-02	-1.75E-02	-1.38E-02	-3.59E-03	1.53E-02
6	-3.95E-02	1.57E-02	1.44E-02	3.54E-03	-6.62E-03	-1.36E-02	-1.53E-02	-1.11E-02	6.82E-04	2.13E-02
7	-1.03E-02	3.27E-02	2.36E-02	8.58E-03	-3.74E-03	-1.16E-02	-1.35E-02	-8.94E-03	3.67E-03	2.55E-02
8	8.85E-03	4.32E-02	2.84E-02	1.03E-02	-3.65E-03	-1.23E-02	-1.43E-02	-9.27E-03	3.60E-03	2.63E-02
9	7.84E-03	4.10E-02	2.47E-02	5.54E-03	-8.85E-03	-1.76E-02	-1.95E-02	-1.45E-02	-9.59E-04	2.23E-02
10	-1.98E-02	2.21E-02	9.28E-03	-7.95E-03	-2.12E-02	-2.91E-02	-3.04E-02	-2.46E-02	-1.11E-02	1.24E-02

Low	1	2	3	4	5	6	7	8	9	10
1	-1.24E-02	4.00E-02	4.11E-02	2.79E-02	1.21E-02	-1.61E-03	-1.11E-02	-1.51E-02	-1.26E-02	-2.28E-03
2	-5.54E-02	1.26E-02	2.18E-02	1.45E-02	3.79E-03	-5.86E-03	-1.13E-02	-1.14E-02	-5.06E-03	9.65E-03
3	-4.34E-02	1.60E-02	2.08E-02	1.23E-02	1.96E-03	-6.40E-03	-1.01E-02	-8.27E-03	9.10E-04	1.87E-02
4	-1.59E-02	2.75E-02	2.35E-02	1.11E-02	-7.24E-04	-9.26E-03	-1.24E-02	-9.17E-03	1.28E-03	2.11E-02
5	-6.10E-03	2.74E-02	1.73E-02	1.98E-03	-1.10E-02	-1.97E-02	-2.25E-02	-1.87E-02	-7.48E-03	1.33E-02

High	1	2	3	4	5	6	7	8	9	10
6	-2.81E-02	3.33E-03	8.38E-03	7.46E-03	5.78E-03	5.07E-03	7.46E-03	1.36E-02	2.55E-02	4.40E-02
7	-1.04E-02	1.03E-02	5.82E-03	-1.12E-03	-6.57E-03	-9.69E-03	-8.98E-03	-4.03E-03	6.74E-03	2.43E-02
8	-1.37E-03	1.88E-02	8.88E-03	-2.58E-03	-1.13E-02	-1.68E-02	-1.79E-02	-1.41E-02	-4.86E-03	1.15E-02
9	-1.15E-03	2.63E-02	1.45E-02	2.63E-04	-1.09E-02	-1.85E-02	-2.12E-02	-1.91E-02	-1.09E-02	4.24E-03
10	-8.86E-03	3.12E-02	2.08E-02	5.43E-03	-7.32E-03	-1.64E-02	-2.05E-02	-1.94E-02	-1.26E-02	1.39E-03

500 keV Poly-SS Exposure (Fractional Difference)

Full	1	2	3	4	5	6	7	8	9	10
1	2.20E-01	1.67E-01	1.30E-01	1.00E-01	7.58E-02	5.58E-02	3.94E-02	2.60E-02	1.54E-02	7.32E-03
2	3.82E-02	3.60E-02	2.82E-02	1.96E-02	1.14E-02	4.22E-03	-1.46E-03	-5.61E-03	-8.09E-03	-8.82E-03
3	-3.56E-02	-2.11E-02	-1.75E-02	-1.72E-02	-1.80E-02	-1.87E-02	-1.87E-02	-1.76E-02	-1.51E-02	-1.12E-02
4	-5.70E-02	-3.71E-02	-3.00E-02	-2.69E-02	-2.49E-02	-2.30E-02	-2.03E-02	-1.66E-02	-1.16E-02	-5.07E-03
5	-5.28E-02	-3.16E-02	-2.44E-02	-2.11E-02	-1.90E-02	-1.66E-02	-1.34E-02	-8.94E-03	-3.05E-03	4.52E-03
6	-3.82E-02	-1.68E-02	-1.06E-02	-8.65E-03	-7.57E-03	-6.12E-03	-3.59E-03	2.73E-04	5.77E-03	1.31E-02
7	-2.24E-02	-8.70E-04	3.89E-03	4.19E-03	3.54E-03	3.33E-03	4.33E-03	6.76E-03	1.09E-02	1.70E-02
8	-1.11E-02	1.09E-02	1.44E-02	1.29E-02	1.03E-02	8.10E-03	7.08E-03	7.51E-03	9.60E-03	1.37E-02
9	-7.33E-03	1.54E-02	1.80E-02	1.50E-02	1.06E-02	5.74E-03	2.57E-03	8.17E-04	6.96E-04	2.33E-03
10	-1.21E-02	1.16E-02	1.29E-02	8.45E-03	2.21E-03	-4.03E-03	-9.43E-03	-1.36E-02	-1.68E-02	-1.79E-02

Low	1	2	3	4	5	6	7	8	9	10
1	7.37E-02	5.28E-02	3.87E-02	2.81E-02	1.95E-02	1.25E-02	6.61E-03	1.40E-03	-3.36E-03	-8.01E-03
2	-2.74E-02	-1.75E-02	-1.35E-02	-1.12E-02	-9.28E-03	-7.57E-03	-5.79E-03	-4.08E-03	-2.54E-03	-1.34E-03
3	-3.83E-02	-2.36E-02	-1.74E-02	-1.33E-02	-9.79E-03	-6.36E-03	-2.78E-03	7.48E-04	4.16E-03	7.23E-03
4	-1.69E-02	-4.61E-03	-1.94E-03	-1.18E-03	-5.13E-04	5.28E-04	2.07E-03	3.87E-03	5.80E-03	7.57E-03
5	7.12E-03	1.59E-02	1.34E-02	9.03E-03	4.85E-03	1.38E-03	-1.29E-03	-3.41E-03	-5.18E-03	-6.88E-03

High	1	2	3	4	5	6	7	8	9	10
6	7.29E-03	1.28E-02	7.43E-03	1.47E-03	-2.76E-03	-4.83E-03	-4.74E-03	-2.88E-03	4.35E-04	4.79E-03
7	-5.70E-03	6.09E-03	4.08E-03	3.10E-05	-3.22E-03	-4.91E-03	-4.83E-03	-3.31E-03	-5.43E-04	3.08E-03
8	-1.26E-02	4.37E-03	5.02E-03	2.30E-03	-4.62E-04	-2.20E-03	-2.58E-03	-1.80E-03	-8.00E-05	2.50E-03
9	-1.74E-02	4.09E-03	7.05E-03	5.46E-03	3.07E-03	5.52E-04	-4.69E-04	-5.67E-04	9.60E-05	1.24E-03
10	-2.24E-02	3.24E-03	7.56E-03	6.83E-03	4.54E-03	2.21E-03	3.65E-04	-8.69E-04	-2.21E-03	-2.63E-03

1 MeV Poly-SS Exposure (Fractional Difference)

Full	1	2	3	4	5	6	7	8	9	10
1	2.27E-01	1.66E-01	1.25E-01	9.46E-02	7.06E-02	5.11E-02	3.48E-02	2.08E-02	8.73E-03	-2.06E-03
2	4.14E-02	3.37E-02	2.53E-02	1.76E-02	1.08E-02	4.83E-03	-4.30E-04	-5.08E-03	-9.24E-03	-1.31E-02
3	-3.49E-02	-2.49E-02	-2.05E-02	-1.81E-02	-1.66E-02	-1.55E-02	-1.45E-02	-1.38E-02	-1.30E-02	-1.25E-02
4	-5.73E-02	-4.25E-02	-3.41E-02	-2.81E-02	-2.32E-02	-1.89E-02	-1.50E-02	-1.14E-02	-8.08E-03	-5.10E-03
5	-5.24E-02	-3.78E-02	-2.95E-02	-2.32E-02	-1.78E-02	-1.28E-02	-8.13E-03	-3.64E-03	6.64E-04	4.64E-03
6	-3.52E-02	-2.29E-02	-1.65E-02	-1.18E-02	-7.54E-03	-3.46E-03	9.35E-04	4.88E-03	8.73E-03	1.29E-02
7	-1.56E-02	-5.81E-03	-2.30E-03	-5.66E-05	2.44E-03	4.68E-03	7.13E-03	1.02E-02	1.29E-02	1.55E-02
8	6.96E-04	7.81E-03	8.44E-03	7.97E-03	8.02E-03	7.99E-03	8.39E-03	9.57E-03	1.05E-02	1.16E-02
9	1.01E-02	1.48E-02	1.27E-02	9.51E-03	6.98E-03	4.54E-03	2.63E-03	1.64E-03	5.50E-04	-3.40E-04
10	1.11E-02	1.37E-02	9.18E-03	3.55E-03	-1.43E-03	-6.26E-03	-1.05E-02	-1.37E-02	-1.69E-02	-1.98E-02

Low	1	2	3	4	5	6	7	8	9	10
1	6.74E-02	4.96E-02	3.71E-02	2.72E-02	1.89E-02	1.19E-02	5.72E-03	1.98E-04	-4.89E-03	-9.85E-03
2	-3.05E-02	-1.95E-02	-1.37E-02	-1.01E-02	-7.55E-03	-5.57E-03	-4.04E-03	-2.85E-03	-2.01E-03	-1.68E-03
3	-3.75E-02	-2.51E-02	-1.79E-02	-1.27E-02	-8.28E-03	-4.38E-03	-8.89E-04	2.22E-03	4.95E-03	7.11E-03
4	-1.14E-02	-5.57E-03	-3.56E-03	-2.16E-03	-7.16E-04	9.44E-04	2.69E-03	4.44E-03	6.09E-03	7.38E-03
5	1.80E-02	1.58E-02	1.07E-02	6.09E-03	2.45E-03	-2.49E-04	-2.30E-03	-3.88E-03	-5.19E-03	-6.54E-03

High	1	2	3	4	5	6	7	8	9	10
6	6.73E-03	6.93E-03	3.95E-03	1.45E-03	-6.23E-05	-7.40E-04	-4.66E-04	-3.15E-04	-1.76E-04	9.74E-05
7	-3.46E-03	8.52E-05	-1.05E-03	-2.25E-03	-2.38E-03	-2.27E-03	-1.69E-03	-4.73E-04	2.14E-04	5.30E-04
8	-5.75E-03	-4.68E-04	-7.28E-04	-1.47E-03	-1.35E-03	-1.15E-03	-5.57E-04	6.16E-04	1.23E-03	1.45E-03
9	-4.81E-03	1.48E-03	1.46E-03	6.19E-04	4.45E-04	2.53E-04	3.66E-04	1.04E-03	1.13E-03	8.26E-04
10	-3.45E-03	3.42E-03	3.29E-03	2.02E-03	1.24E-03	3.20E-04	-3.43E-04	-4.84E-04	-1.21E-03	-2.33E-03

2 MeV Poly-SS Exposure (Fractional Difference)

Full	1	2	3	4	5	6	7	8	9	10
1	1.98E-01	1.45E-01	1.09E-01	8.17E-02	5.96E-02	4.11E-02	2.54E-02	1.18E-02	-6.34E-05	-1.05E-02
2	3.27E-02	2.83E-02	2.27E-02	1.67E-02	1.06E-02	4.58E-03	-1.08E-03	-6.36E-03	-1.12E-02	-1.56E-02
3	-3.76E-02	-2.51E-02	-1.80E-02	-1.41E-02	-1.20E-02	-1.11E-02	-1.09E-02	-1.11E-02	-1.15E-02	-1.21E-02
4	-5.89E-02	-4.19E-02	-3.08E-02	-2.30E-02	-1.73E-02	-1.32E-02	-9.99E-03	-7.48E-03	-5.41E-03	-3.62E-03
5	-5.37E-02	-3.81E-02	-2.73E-02	-1.93E-02	-1.30E-02	-8.00E-03	-3.84E-03	-2.96E-04	2.85E-03	5.69E-03
6	-3.58E-02	-2.41E-02	-1.60E-02	-9.74E-03	-4.63E-03	-3.09E-04	3.45E-03	6.84E-03	9.97E-03	1.29E-02
7	-1.42E-02	-7.57E-03	-3.25E-03	1.62E-04	3.10E-03	5.74E-03	8.21E-03	1.06E-02	1.29E-02	1.53E-02
8	4.89E-03	6.36E-03	6.51E-03	6.59E-03	6.82E-03	7.25E-03	7.89E-03	8.77E-03	9.83E-03	1.11E-02
9	1.77E-02	1.44E-02	1.05E-02	7.15E-03	4.52E-03	2.55E-03	1.14E-03	2.34E-04	-2.51E-04	-3.66E-04
10	2.25E-02	1.48E-02	7.25E-03	7.93E-04	-4.54E-03	-8.87E-03	-1.23E-02	-1.51E-02	-1.72E-02	-1.88E-02

Low	1	2	3	4	5	6	7	8	9	10
1	5.90E-02	4.31E-02	3.21E-02	2.33E-02	1.57E-02	9.07E-03	3.24E-03	-1.87E-03	-6.34E-03	-1.03E-02
2	-2.97E-02	-1.86E-02	-1.20E-02	-8.01E-03	-5.50E-03	-3.92E-03	-2.88E-03	-2.14E-03	-1.53E-03	-1.04E-03
3	-3.55E-02	-2.35E-02	-1.56E-02	-9.97E-03	-5.68E-03	-2.29E-03	5.50E-04	3.02E-03	5.27E-03	7.33E-03
4	-9.48E-03	-5.50E-03	-3.15E-03	-1.39E-03	2.27E-04	1.62E-03	2.98E-03	4.37E-03	5.80E-03	7.27E-03
5	2.05E-02	1.43E-02	8.81E-03	4.46E-03	1.10E-03	-1.45E-03	-3.33E-03	-4.67E-03	-5.53E-03	-6.02E-03

High	1	2	3	4	5	6	7	8	9	10
6	4.91E-03	4.32E-03	3.25E-03	2.42E-03	1.77E-03	1.21E-03	6.16E-04	-1.11E-04	-1.05E-03	-2.30E-03
7	-3.70E-03	-2.58E-03	-2.22E-03	-1.77E-03	-1.20E-03	-6.33E-04	-1.70E-04	1.04E-04	1.15E-04	-2.47E-04
8	-4.10E-03	-2.88E-03	-2.45E-03	-1.86E-03	-1.09E-03	-2.79E-04	4.71E-04	1.07E-03	1.40E-03	1.37E-03
9	-5.46E-04	-1.63E-04	-4.80E-04	-4.90E-04	-2.10E-04	2.52E-04	7.46E-04	1.15E-03	1.35E-03	1.24E-03
10	3.91E-03	2.96E-03	1.43E-03	3.64E-04	-2.42E-04	-5.42E-04	-6.89E-04	-8.38E-04	-1.10E-03	-1.59E-03

6 MeV Poly-SS Exposure (Fractional Difference)

Full	1	2	3	4	5	6	7	8	9	10
1	1.29E-01	1.18E-01	1.03E-01	8.58E-02	6.73E-02	4.90E-02	3.17E-02	1.60E-02	2.19E-03	-9.45E-03
2	9.27E-03	2.40E-02	2.84E-02	2.58E-02	1.92E-02	1.07E-02	1.73E-03	-6.56E-03	-1.40E-02	-1.98E-02
3	-4.36E-02	-1.97E-02	-7.63E-03	-3.41E-03	-3.67E-03	-6.61E-03	-1.03E-02	-1.42E-02	-1.74E-02	-1.92E-02
4	-6.03E-02	-3.48E-02	-2.03E-02	-1.32E-02	-1.05E-02	-1.05E-02	-1.15E-02	-1.23E-02	-1.27E-02	-1.18E-02
5	-5.58E-02	-3.26E-02	-1.88E-02	-1.14E-02	-7.86E-03	-6.60E-03	-5.91E-03	-5.32E-03	-3.94E-03	-1.05E-03
6	-3.91E-02	-2.09E-02	-9.73E-03	-3.83E-03	-8.19E-04	4.53E-04	1.58E-03	2.93E-03	5.31E-03	9.42E-03
7	-1.75E-02	-5.86E-03	1.15E-03	4.48E-03	5.95E-03	6.42E-03	7.26E-03	8.71E-03	1.15E-02	1.63E-02
8	2.85E-03	6.96E-03	9.06E-03	9.16E-03	8.53E-03	7.68E-03	7.76E-03	8.86E-03	1.16E-02	1.66E-02
9	1.66E-02	1.30E-02	9.99E-03	6.66E-03	3.71E-03	1.30E-03	1.47E-04	8.41E-04	3.26E-03	8.11E-03
10	2.01E-02	9.16E-03	1.33E-03	-5.26E-03	-1.04E-02	-1.44E-02	-1.66E-02	-1.67E-02	-1.48E-02	-1.03E-02

Low	1	2	3	4	5	6	7	8	9	10
1	3.69E-02	3.33E-02	3.02E-02	2.51E-02	1.86E-02	1.16E-02	4.52E-03	-2.07E-03	-7.90E-03	-1.28E-02
2	-3.01E-02	-1.73E-02	-8.52E-03	-3.86E-03	-2.01E-03	-1.84E-03	-2.54E-03	-3.23E-03	-3.89E-03	-3.78E-03
3	-3.22E-02	-2.10E-02	-1.23E-02	-6.63E-03	-2.93E-03	-7.74E-04	9.76E-04	2.39E-03	4.08E-03	6.56E-03
4	-7.01E-03	-5.32E-03	-2.53E-03	-5.39E-04	9.25E-04	1.83E-03	2.76E-03	4.26E-03	6.14E-03	9.07E-03
5	2.27E-02	1.17E-02	5.86E-03	1.70E-03	-1.27E-03	-3.61E-03	-4.85E-03	-5.36E-03	-4.82E-03	-2.90E-03

High	1	2	3	4	5	6	7	8	9	10
6	5.96E-04	1.62E-03	3.60E-03	4.45E-03	4.35E-03	3.15E-03	1.66E-03	-2.81E-04	-2.21E-03	-3.70E-03
7	-4.93E-03	-4.15E-03	-1.80E-03	-1.97E-04	6.77E-04	5.99E-04	3.07E-04	-3.99E-04	-1.08E-03	-1.31E-03
8	-3.35E-03	-4.09E-03	-2.45E-03	-1.03E-03	2.21E-05	3.59E-04	6.36E-04	6.11E-04	6.90E-04	1.26E-03
9	1.85E-03	-1.31E-03	-1.16E-03	-5.94E-04	3.36E-05	2.47E-04	3.97E-04	8.45E-04	1.30E-03	2.32E-03
10	7.94E-03	1.73E-03	-1.56E-04	-9.29E-04	-1.17E-03	-1.49E-03	-1.61E-03	-1.24E-03	-7.33E-04	4.69E-04

10 MeV Poly-SS Exposure (Fractional Difference)

Full	1	2	3	4	5	6	7	8	9	10
1	9.58E-02	9.59E-02	9.23E-02	8.39E-02	7.23E-02	5.88E-02	4.48E-02	3.12E-02	1.84E-02	7.14E-03
2	-8.43E-04	1.43E-02	2.17E-02	2.24E-02	1.87E-02	1.24E-02	4.90E-03	-3.00E-03	-1.01E-02	-1.61E-02
3	-4.18E-02	-2.22E-02	-1.07E-02	-5.96E-03	-5.79E-03	-8.29E-03	-1.21E-02	-1.63E-02	-1.98E-02	-2.22E-02
4	-5.31E-02	-3.32E-02	-2.07E-02	-1.45E-02	-1.26E-02	-1.31E-02	-1.47E-02	-1.66E-02	-1.77E-02	-1.74E-02
5	-4.70E-02	-2.90E-02	-1.74E-02	-1.13E-02	-8.99E-03	-8.68E-03	-9.14E-03	-9.62E-03	-8.93E-03	-6.68E-03
6	-3.12E-02	-1.68E-02	-7.38E-03	-2.50E-03	-6.60E-04	-3.42E-04	-3.59E-04	-2.38E-05	1.81E-03	5.55E-03
7	-1.22E-02	-2.52E-03	3.83E-03	6.73E-03	7.39E-03	7.14E-03	7.03E-03	7.68E-03	1.02E-02	1.50E-02
8	4.43E-03	8.57E-03	1.12E-02	1.17E-02	1.07E-02	9.51E-03	8.93E-03	9.50E-03	1.23E-02	1.77E-02
9	1.35E-02	1.18E-02	1.06E-02	8.35E-03	5.59E-03	3.17E-03	1.86E-03	2.05E-03	4.76E-03	1.03E-02
10	1.12E-02	3.85E-03	-1.16E-03	-5.98E-03	-1.05E-02	-1.42E-02	-1.64E-02	-1.68E-02	-1.45E-02	-9.26E-03

Low	1	2	3	4	5	6	7	8	9	10
1	2.33E-02	2.51E-02	2.65E-02	2.47E-02	2.02E-02	1.42E-02	7.42E-03	5.94E-04	-5.69E-03	-1.10E-02
2	-2.78E-02	-1.61E-02	-7.40E-03	-2.74E-03	-1.21E-03	-1.65E-03	-3.07E-03	-4.92E-03	-6.16E-03	-6.49E-03
3	-2.73E-02	-1.78E-02	-9.69E-03	-4.59E-03	-1.90E-03	-6.54E-04	-2.88E-06	5.24E-04	1.93E-03	4.49E-03
4	-5.57E-03	-3.95E-03	-8.79E-04	1.12E-03	2.01E-03	2.39E-03	2.85E-03	3.73E-03	5.92E-03	9.64E-03
5	1.85E-02	9.05E-03	4.59E-03	1.31E-03	-1.54E-03	-3.82E-03	-5.20E-03	-5.57E-03	-4.15E-03	-8.40E-04

High	1	2	3	4	5	6	7	8	9	10
6	-6.16E-04	-1.60E-04	2.54E-03	4.29E-03	4.58E-03	3.76E-03	2.23E-03	1.95E-04	-1.58E-03	-3.02E-03
7	-4.29E-03	-4.59E-03	-2.03E-03	-1.89E-05	8.45E-04	7.93E-04	2.07E-04	-7.72E-04	-1.38E-03	-1.56E-03
8	-2.18E-03	-4.07E-03	-2.34E-03	-6.59E-04	2.18E-04	4.52E-04	3.54E-04	2.94E-05	2.07E-04	9.51E-04
9	2.72E-03	-1.40E-03	-1.06E-03	-1.96E-04	2.67E-04	3.83E-04	4.06E-04	3.83E-04	1.03E-03	2.37E-03
10	7.95E-03	1.11E-03	-3.68E-04	-7.11E-04	-1.03E-03	-1.36E-03	-1.53E-03	-1.55E-03	-7.35E-04	9.22E-04

Stainless Steel Followed by Polyethylene

65 keV SS-Poly Exposure (Log Fractional Difference)

Full	1	2	3	4	5	6	7	8	9	10
1	8.28E-02	4.74E-02	2.39E-02	1.17E-02	3.95E-03	-2.07E-03	-6.96E-03	-1.04E-02	-1.19E-02	-1.07E-02
2	2.80E-02	1.27E-02	1.48E-03	-2.70E-03	-4.73E-03	-6.55E-03	-8.17E-03	-8.99E-03	-8.25E-03	-5.18E-03
3	-5.70E-03	-6.95E-03	-9.57E-03	-8.14E-03	-6.33E-03	-5.36E-03	-4.88E-03	-4.06E-03	-1.91E-03	2.36E-03
4	-2.54E-02	-1.68E-02	-1.35E-02	-8.44E-03	-4.23E-03	-1.62E-03	1.95E-05	1.74E-03	4.59E-03	9.50E-03
5	-3.44E-02	-1.96E-02	-1.28E-02	-5.82E-03	-5.15E-04	2.70E-03	4.67E-03	6.59E-03	9.57E-03	1.46E-02
6	-3.48E-02	-1.70E-02	-9.07E-03	-1.75E-03	3.40E-03	6.24E-03	7.79E-03	9.25E-03	1.18E-02	1.66E-02
7	-2.79E-02	-1.03E-02	-3.46E-03	2.51E-03	6.27E-03	7.84E-03	8.19E-03	8.63E-03	1.03E-02	1.43E-02
8	-1.48E-02	-7.22E-04	2.80E-03	5.87E-03	7.13E-03	6.52E-03	5.05E-03	3.94E-03	4.28E-03	7.11E-03
9	3.41E-03	1.08E-02	8.87E-03	7.52E-03	5.19E-03	1.66E-03	-2.24E-03	-5.36E-03	-6.72E-03	-5.39E-03
10	2.58E-02	2.32E-02	1.37E-02	6.53E-03	-3.50E-04	-7.48E-03	-1.43E-02	-1.98E-02	-2.32E-02	-2.36E-02

Low	1	2	3	4	5	6	7	8	9	10
1	2.98E-02	1.54E-02	5.30E-03	1.86E-03	8.78E-05	-1.89E-03	-4.05E-03	-5.71E-03	-6.06E-03	-4.33E-03
2	-8.00E-03	-6.31E-03	-6.73E-03	-3.91E-03	-1.36E-03	-2.28E-04	-7.01E-06	2.00E-04	1.40E-03	4.52E-03
3	-1.97E-02	-1.09E-02	-7.58E-03	-2.65E-03	1.08E-03	2.92E-03	3.55E-03	4.02E-03	5.45E-03	8.75E-03
4	-1.24E-02	-4.15E-03	-2.20E-03	1.10E-03	3.24E-03	3.62E-03	2.94E-03	2.31E-03	2.77E-03	5.26E-03
5	1.02E-02	1.06E-02	6.17E-03	4.34E-03	2.31E-03	-7.17E-04	-4.19E-03	-7.15E-03	-8.65E-03	-7.82E-03

High	1	2	3	4	5	6	7	8	9	10
6	8.61E-02	2.19E-01	3.42E-01	4.49E-01	5.40E-01	6.16E-01	6.79E-01	7.33E-01	7.81E-01	8.27E-01
7	7.59E-02	2.14E-01	3.40E-01	4.50E-01	5.42E-01	6.18E-01	6.82E-01	7.36E-01	7.85E-01	8.30E-01
8	7.17E-02	2.13E-01	3.41E-01	4.52E-01	5.45E-01	6.21E-01	6.84E-01	7.38E-01	7.86E-01	8.31E-01
9	7.26E-02	2.16E-01	3.45E-01	4.55E-01	5.47E-01	6.22E-01	6.85E-01	7.37E-01	7.84E-01	8.28E-01
10	7.78E-02	2.21E-01	3.49E-01	4.58E-01	5.48E-01	6.22E-01	6.82E-01	7.33E-01	7.78E-01	8.21E-01

100 keV SS-Poly Exposure (Fractional Difference for Log Fit)

Full	1	2	3	4	5	6	7	8	9	10
1	1.60E-01	1.04E-01	5.95E-02	3.16E-02	1.37E-02	1.45E-03	-7.39E-03	-1.38E-02	-1.80E-02	-2.02E-02
2	4.30E-02	2.73E-02	6.69E-03	-5.16E-03	-1.13E-02	-1.46E-02	-1.64E-02	-1.69E-02	-1.62E-02	-1.42E-02
3	-2.09E-02	-1.23E-02	-1.75E-02	-1.89E-02	-1.75E-02	-1.51E-02	-1.22E-02	-9.13E-03	-5.43E-03	-8.73E-04
4	-5.43E-02	-3.00E-02	-2.53E-02	-2.01E-02	-1.40E-02	-8.12E-03	-2.73E-03	2.40E-03	7.70E-03	1.36E-02
5	-6.69E-02	-3.30E-02	-2.27E-02	-1.40E-02	-5.79E-03	1.46E-03	7.74E-03	1.34E-02	1.91E-02	2.53E-02
6	-6.39E-02	-2.58E-02	-1.38E-02	-4.78E-03	3.22E-03	9.91E-03	1.55E-02	2.05E-02	2.54E-02	3.08E-02
7	-4.88E-02	-1.17E-02	-2.02E-03	4.47E-03	9.97E-03	1.43E-02	1.77E-02	2.07E-02	2.38E-02	2.77E-02
8	-2.43E-02	6.59E-03	1.00E-02	1.10E-02	1.18E-02	1.21E-02	1.20E-02	1.20E-02	1.25E-02	1.41E-02
9	6.53E-03	2.61E-02	1.96E-02	1.25E-02	6.71E-03	1.53E-03	-3.08E-03	-6.93E-03	-9.69E-03	-1.10E-02
10	4.14E-02	4.44E-02	2.45E-02	7.14E-03	-6.82E-03	-1.85E-02	-2.84E-02	-3.66E-02	-4.30E-02	-4.75E-02

Low	1	2	3	4	5	6	7	8	9	10
1	5.85E-02	3.61E-02	1.56E-02	4.84E-03	-6.06E-04	-3.88E-03	-6.38E-03	-8.55E-03	-1.04E-02	-1.17E-02
2	-2.04E-02	-1.09E-02	-1.26E-02	-1.08E-02	-7.01E-03	-3.25E-03	-2.33E-04	2.05E-03	3.88E-03	5.59E-03
3	-4.10E-02	-1.87E-02	-1.38E-02	-7.96E-03	-1.65E-03	3.76E-03	7.93E-03	1.10E-02	1.34E-02	1.55E-02
4	-2.47E-02	-3.54E-03	-1.90E-03	4.56E-04	3.48E-03	5.98E-03	7.52E-03	8.27E-03	8.62E-03	8.98E-03
5	1.81E-02	2.52E-02	1.43E-02	6.35E-03	9.81E-04	-3.47E-03	-7.68E-03	-1.17E-02	-1.55E-02	-1.86E-02

High	1	2	3	4	5	6	7	8	9	10
6	-5.74E-02	-2.07E-02	2.81E-02	8.21E-02	1.35E-01	1.83E-01	2.26E-01	2.62E-01	2.94E-01	3.21E-01
7	-7.24E-02	-2.89E-02	2.43E-02	8.13E-02	1.36E-01	1.86E-01	2.29E-01	2.66E-01	2.98E-01	3.25E-01
8	-7.83E-02	-3.06E-02	2.51E-02	8.35E-02	1.39E-01	1.89E-01	2.32E-01	2.69E-01	3.00E-01	3.26E-01
9	-7.72E-02	-2.75E-02	2.87E-02	8.69E-02	1.42E-01	1.90E-01	2.32E-01	2.68E-01	2.98E-01	3.22E-01
10	-7.02E-02	-2.12E-02	3.38E-02	9.01E-02	1.43E-01	1.89E-01	2.29E-01	2.62E-01	2.90E-01	3.13E-01

500 keV SS-Poly Exposure (Log Fit Fractional Difference)

Full	1	2	3	4	5	6	7	8	9	10
1	2.23E-01	1.72E-01	1.25E-01	8.55E-02	5.14E-02	2.26E-02	-1.46E-03	-2.13E-02	-3.70E-02	-4.89E-02
2	2.24E-02	3.01E-02	2.17E-02	9.90E-03	-2.09E-03	-1.30E-02	-2.23E-02	-2.97E-02	-3.48E-02	-3.76E-02
3	-7.29E-02	-3.75E-02	-2.61E-02	-2.26E-02	-2.21E-02	-2.24E-02	-2.25E-02	-2.18E-02	-1.98E-02	-1.61E-02
4	-1.09E-01	-5.95E-02	-3.83E-02	-2.74E-02	-2.05E-02	-1.51E-02	-1.00E-02	-4.46E-03	2.15E-03	1.02E-02
5	-1.06E-01	-5.15E-02	-2.79E-02	-1.52E-02	-6.59E-03	6.18E-04	7.77E-03	1.56E-02	2.46E-02	3.51E-02
6	-7.78E-02	-2.55E-02	-5.48E-03	4.09E-03	1.05E-02	1.65E-02	2.32E-02	3.11E-02	4.07E-02	5.23E-02
7	-3.49E-02	7.45E-03	1.82E-02	2.07E-02	2.20E-02	2.45E-02	2.88E-02	3.53E-02	4.41E-02	5.54E-02
8	9.68E-03	3.52E-02	3.26E-02	2.53E-02	1.96E-02	1.72E-02	1.81E-02	2.23E-02	2.95E-02	3.98E-02
9	4.26E-02	4.66E-02	2.85E-02	1.05E-02	-2.53E-03	-1.02E-02	-1.29E-02	-1.13E-02	-5.96E-03	2.88E-03
10	5.25E-02	3.37E-02	5.85E-04	-2.72E-02	-4.68E-02	-5.89E-02	-6.48E-02	-6.56E-02	-6.20E-02	-5.46E-02

Low	1	2	3	4	5	6	7	8	9	10
1	7.20E-02	5.21E-02	3.46E-02	2.05E-02	8.70E-03	-1.57E-03	-1.06E-02	-1.86E-02	-2.55E-02	-3.13E-02
2	-4.80E-02	-2.59E-02	-1.63E-02	-1.02E-02	-5.73E-03	-2.44E-03	-6.74E-05	1.64E-03	3.06E-03	4.41E-03
3	-6.03E-02	-3.03E-02	-1.63E-02	-6.60E-03	1.36E-03	8.13E-03	1.39E-02	1.89E-02	2.34E-02	2.75E-02
4	-1.69E-02	-3.16E-04	2.33E-03	3.65E-03	5.70E-03	8.47E-03	1.16E-02	1.50E-02	1.85E-02	2.21E-02
5	4.45E-02	3.21E-02	1.26E-02	-2.16E-03	-1.18E-02	-1.76E-02	-2.07E-02	-2.20E-02	-2.19E-02	-2.09E-02

High	1	2	3	4	5	6	7	8	9	10
6	-5.24E-01	-6.15E-01	-6.62E-01	-6.88E-01	-7.03E-01	-7.13E-01	-7.20E-01	-7.26E-01	-7.31E-01	-7.35E-01
7	-5.40E-01	-6.26E-01	-6.70E-01	-6.93E-01	-7.07E-01	-7.16E-01	-7.22E-01	-7.27E-01	-7.31E-01	-7.35E-01
8	-5.48E-01	-6.32E-01	-6.74E-01	-6.97E-01	-7.10E-01	-7.18E-01	-7.24E-01	-7.29E-01	-7.32E-01	-7.36E-01
9	-5.52E-01	-6.34E-01	-6.77E-01	-7.00E-01	-7.13E-01	-7.21E-01	-7.26E-01	-7.31E-01	-7.34E-01	-7.38E-01
10	-5.53E-01	-6.37E-01	-6.80E-01	-7.03E-01	-7.16E-01	-7.24E-01	-7.30E-01	-7.34E-01	-7.38E-01	-7.41E-01

1 MeV SS-Poly Exposure (Fractional Difference)

Full	1	2	3	4	5	6	7	8	9	10
1	9.80E-01	5.13E-01	2.45E-01	7.98E-02	-2.23E-02	-7.98E-02	-9.57E-02	8.30E-03	-1.75E-01	-5.55E-02
2	5.45E-01	2.45E-01	6.48E-02	-4.53E-02	-1.11E-01	-1.42E-01	-1.43E-01	-1.10E-01	1.84E-02	6.28E-02
3	3.41E-01	1.22E-01	-6.95E-03	-8.10E-02	-1.17E-01	-1.23E-01	-9.92E-02	-4.44E-02	2.94E-02	-5.63E-02
4	2.41E-01	6.87E-02	-2.90E-02	-7.90E-02	-9.55E-02	-8.44E-02	-4.86E-02	6.47E-03	5.64E-02	1.86E-02
5	1.91E-01	4.78E-02	-2.96E-02	-6.40E-02	-6.83E-02	-4.90E-02	-1.12E-02	3.50E-02	6.53E-02	2.97E-02
6	1.67E-01	4.16E-02	-2.29E-02	-4.77E-02	-4.54E-02	-2.38E-02	1.04E-02	4.57E-02	6.09E-02	2.42E-02
7	1.54E-01	4.06E-02	-1.58E-02	-3.51E-02	-3.03E-02	-9.75E-03	1.85E-02	4.33E-02	4.75E-02	9.81E-03
8	1.46E-01	4.03E-02	-1.13E-02	-2.80E-02	-2.31E-02	-5.66E-03	1.61E-02	3.19E-02	2.81E-02	-9.86E-03
9	1.40E-01	3.84E-02	-1.06E-02	-2.65E-02	-2.31E-02	-9.53E-03	6.06E-03	1.44E-02	4.88E-03	-3.28E-02
10	1.32E-01	3.38E-02	-1.40E-02	-3.04E-02	-2.91E-02	-1.95E-02	-9.57E-03	-7.09E-03	-2.07E-02	-5.76E-02

Low	1	2	3	4	5	6	7	8	9	10
1	1.81E-02	4.49E-02	4.90E-02	4.46E-02	3.65E-02	2.67E-02	1.59E-02	4.60E-03	-7.26E-03	-1.96E-02
2	-6.10E-02	-2.98E-02	-1.46E-02	-5.86E-03	-9.57E-04	1.17E-03	1.15E-03	-7.01E-04	-4.28E-03	-9.41E-03
3	-4.51E-02	-3.37E-02	-2.51E-02	-1.67E-02	-9.12E-03	-3.05E-03	1.31E-03	3.88E-03	4.53E-03	3.32E-03
4	7.69E-03	-7.43E-03	-1.26E-02	-1.09E-02	-6.34E-03	-1.27E-03	3.19E-03	6.51E-03	8.24E-03	8.24E-03
5	6.52E-02	2.34E-02	2.61E-03	-5.18E-03	-6.67E-03	-5.55E-03	-3.70E-03	-2.22E-03	-1.76E-03	-2.61E-03

High	1	2	3	4	5	6	7	8	9	10
6	-1.74E-02	1.79E-03	9.38E-03	1.29E-02	1.32E-02	1.07E-02	6.33E-03	7.89E-04	-5.22E-03	-1.10E-02
7	-1.90E-02	-7.29E-03	-1.97E-03	2.04E-03	4.24E-03	4.42E-03	2.84E-03	2.43E-04	-2.86E-03	-5.79E-03
8	-8.90E-03	-6.60E-03	-5.33E-03	-2.45E-03	2.11E-04	1.73E-03	2.03E-03	1.48E-03	5.48E-04	-1.53E-04
9	7.52E-03	-8.04E-04	-4.81E-03	-4.22E-03	-2.12E-03	-2.01E-04	1.11E-03	1.92E-03	2.56E-03	3.56E-03
10	2.53E-02	5.74E-03	-4.26E-03	-6.70E-03	-5.90E-03	-4.18E-03	-2.52E-03	-8.89E-04	8.33E-04	3.10E-03

2 MeV SS-Poly Exposure (Fractional Difference)

Full	1	2	3	4	5	6	7	8	9	10
1	1.90E-01	1.38E-01	1.04E-01	7.95E-02	5.93E-02	4.20E-02	2.69E-02	1.32E-02	6.62E-04	-1.11E-02
2	2.65E-02	1.98E-02	1.71E-02	1.42E-02	1.04E-02	5.86E-03	7.98E-04	-4.69E-03	-1.05E-02	-1.68E-02
3	-3.83E-02	-3.20E-02	-2.31E-02	-1.61E-02	-1.17E-02	-9.41E-03	-8.74E-03	-9.39E-03	-1.11E-02	-1.38E-02
4	-5.35E-02	-4.66E-02	-3.48E-02	-2.44E-02	-1.66E-02	-1.12E-02	-7.70E-03	-5.86E-03	-5.39E-03	-6.13E-03
5	-4.30E-02	-4.08E-02	-3.05E-02	-2.01E-02	-1.18E-02	-5.61E-03	-1.28E-03	1.44E-03	2.76E-03	2.81E-03
6	-2.14E-02	-2.60E-02	-1.91E-02	-1.06E-02	-3.45E-03	2.07E-03	6.00E-03	8.51E-03	9.74E-03	9.80E-03
7	1.86E-03	-9.76E-03	-7.06E-03	-1.41E-03	3.78E-03	7.80E-03	1.06E-02	1.22E-02	1.28E-02	1.23E-02
8	2.08E-02	2.60E-03	1.08E-03	3.71E-03	6.58E-03	8.76E-03	1.01E-02	1.05E-02	1.01E-02	8.82E-03
9	3.20E-02	8.09E-03	2.76E-03	2.52E-03	3.10E-03	3.39E-03	3.14E-03	2.27E-03	7.78E-04	-1.37E-03
10	3.38E-02	5.38E-03	-3.15E-03	-5.89E-03	-7.36E-03	-8.78E-03	-1.05E-02	-1.26E-02	-1.51E-02	-1.81E-02

Low	1	2	3	4	5	6	7	8	9	10
1	5.04E-02	4.02E-02	3.22E-02	2.45E-02	1.70E-02	1.00E-02	3.68E-03	-2.03E-03	-7.09E-03	-1.15E-02
2	-3.23E-02	-2.12E-02	-1.23E-02	-6.80E-03	-3.76E-03	-2.29E-03	-1.72E-03	-1.63E-03	-1.79E-03	-2.03E-03
3	-3.15E-02	-2.54E-02	-1.66E-02	-9.54E-03	-4.48E-03	-9.37E-04	1.62E-03	3.56E-03	5.12E-03	6.47E-03
4	-7.27E-04	-7.64E-03	-5.69E-03	-2.52E-03	8.52E-05	2.02E-03	3.52E-03	4.74E-03	5.84E-03	6.88E-03
5	3.13E-02	1.03E-02	3.71E-03	1.03E-03	-6.89E-04	-2.07E-03	-3.20E-03	-4.08E-03	-4.72E-03	-5.11E-03

High	1	2	3	4	5	6	7	8	9	10
6	6.99E-05	-7.88E-04	3.62E-03	6.34E-03	6.45E-03	4.75E-03	2.12E-03	-7.69E-04	-3.41E-03	-5.46E-03
7	-4.26E-03	-7.46E-03	-3.04E-03	7.05E-04	2.26E-03	2.13E-03	1.09E-03	-2.45E-04	-1.38E-03	-2.02E-03
8	-3.32E-04	-7.44E-03	-4.46E-03	-9.39E-04	9.77E-04	1.52E-03	1.30E-03	8.86E-04	6.92E-04	1.02E-03
9	7.24E-03	-4.54E-03	-3.78E-03	-1.27E-03	3.24E-04	9.35E-04	1.04E-03	1.08E-03	1.43E-03	2.35E-03
10	1.48E-02	-1.82E-03	-3.65E-03	-2.52E-03	-1.64E-03	-1.31E-03	-1.24E-03	-1.04E-03	-4.32E-04	8.45E-04

6 MeV SS-Poly Exposure (Fractional Difference)

Full	1	2	3	4	5	6	7	8	9	10
1	7.04E-02	6.15E-02	4.71E-02	3.26E-02	2.01E-02	1.04E-02	3.94E-03	8.03E-04	1.02E-03	4.67E-03
2	-1.45E-02	4.55E-03	6.43E-03	2.61E-03	-2.36E-03	-6.38E-03	-8.48E-03	-8.07E-03	-4.91E-03	1.26E-03
3	-4.16E-02	-1.57E-02	-8.68E-03	-8.62E-03	-1.06E-02	-1.22E-02	-1.23E-02	-1.02E-02	-5.56E-03	1.87E-03
4	-3.97E-02	-1.52E-02	-8.35E-03	-8.08E-03	-9.68E-03	-1.09E-02	-1.06E-02	-8.08E-03	-3.10E-03	4.65E-03
5	-2.60E-02	-5.31E-03	-5.66E-04	-1.69E-03	-4.23E-03	-6.09E-03	-6.28E-03	-4.20E-03	4.40E-04	7.89E-03
6	-1.12E-02	6.13E-03	8.66E-03	5.91E-03	2.10E-03	-7.90E-04	-1.86E-03	-5.55E-04	3.36E-03	1.01E-02
7	-1.50E-03	1.40E-02	1.53E-02	1.14E-02	6.61E-03	2.80E-03	8.61E-04	1.32E-03	4.38E-03	1.03E-02
8	2.10E-04	1.57E-02	1.69E-02	1.28E-02	7.60E-03	3.25E-03	6.89E-04	4.47E-04	2.75E-03	7.79E-03
9	-6.74E-03	1.03E-02	1.26E-02	9.20E-03	4.25E-03	-1.28E-04	-2.96E-03	-3.65E-03	-1.96E-03	2.34E-03
10	-2.16E-02	-1.96E-03	2.50E-03	5.06E-04	-3.55E-03	-7.47E-03	-1.02E-02	-1.10E-02	-9.72E-03	-6.01E-03

Low	1	2	3	4	5	6	7	8	9	10
1	3.84E-02	2.18E-02	1.17E-02	5.38E-03	1.15E-03	-1.52E-03	-2.96E-03	-3.30E-03	-2.70E-03	-1.16E-03
2	-1.74E-02	-9.26E-03	-6.72E-03	-5.71E-03	-5.05E-03	-4.20E-03	-3.01E-03	-1.29E-03	9.83E-04	3.89E-03
3	-2.19E-02	-8.34E-03	-3.79E-03	-2.15E-03	-1.40E-03	-7.06E-04	2.62E-04	1.74E-03	3.76E-03	6.43E-03
4	-1.07E-02	2.25E-03	5.05E-03	4.58E-03	3.26E-03	2.07E-03	1.35E-03	1.33E-03	2.03E-03	3.51E-03
5	-3.13E-03	8.69E-03	9.49E-03	6.65E-03	2.94E-03	-4.92E-04	-3.26E-03	-5.16E-03	-6.15E-03	-6.22E-03

High	1	2	3	4	5	6	7	8	9	10
6	-9.42E-03	6.18E-03	7.39E-03	3.69E-03	-7.48E-04	-4.01E-03	-5.22E-03	-3.85E-03	3.10E-04	7.50E-03
7	-8.75E-03	6.35E-03	7.43E-03	3.55E-03	-1.08E-03	-4.60E-03	-6.15E-03	-5.16E-03	-1.47E-03	5.21E-03
8	-8.30E-03	7.25E-03	8.69E-03	4.97E-03	2.34E-04	-3.53E-03	-5.43E-03	-4.90E-03	-1.72E-03	4.33E-03
9	-1.03E-02	6.70E-03	9.23E-03	6.13E-03	1.65E-03	-2.14E-03	-4.25E-03	-4.09E-03	-1.42E-03	4.01E-03
10	-1.57E-02	3.62E-03	7.92E-03	5.96E-03	2.14E-03	-1.35E-03	-3.46E-03	-3.52E-03	-1.24E-03	3.64E-03

10 MeV SS-Poly Exposure (Fractional Difference)

Full	1	2	3	4	5	6	7	8	9	10
1	2.03E-02	4.87E-02	4.29E-02	2.87E-02	1.45E-02	3.35E-03	-3.52E-03	-5.64E-03	-2.84E-03	4.99E-03
2	-3.23E-02	1.31E-02	1.74E-02	9.93E-03	5.62E-04	-6.89E-03	-1.08E-02	-1.05E-02	-5.70E-03	3.93E-03
3	-4.64E-02	-5.64E-05	6.70E-03	1.64E-03	-5.61E-03	-1.12E-02	-1.36E-02	-1.19E-02	-5.89E-03	4.84E-03
4	-4.01E-02	4.86E-04	5.70E-03	4.94E-04	-6.38E-03	-1.14E-02	-1.32E-02	-1.09E-02	-4.32E-03	6.94E-03
5	-2.56E-02	7.62E-03	9.84E-03	3.35E-03	-4.04E-03	-9.26E-03	-1.10E-02	-8.67E-03	-1.95E-03	9.43E-03
6	-1.14E-02	1.58E-02	1.53E-02	7.48E-03	-6.32E-04	-6.27E-03	-8.30E-03	-6.16E-03	3.93E-04	1.16E-02
7	-3.04E-03	2.10E-02	1.92E-02	1.07E-02	2.14E-03	-3.83E-03	-6.14E-03	-4.28E-03	1.96E-03	1.28E-02
8	-3.25E-03	2.09E-02	1.95E-02	1.13E-02	2.94E-03	-3.01E-03	-5.43E-03	-3.78E-03	2.15E-03	1.26E-02
9	-1.27E-02	1.42E-02	1.51E-02	8.45E-03	9.99E-04	-4.45E-03	-6.68E-03	-5.08E-03	6.25E-04	1.07E-02
10	-3.09E-02	1.01E-03	5.72E-03	1.62E-03	-4.17E-03	-8.60E-03	-1.03E-02	-8.48E-03	-2.87E-03	6.87E-03

Low	1	2	3	4	5	6	7	8	9	10
1	3.10E-02	1.61E-02	6.53E-03	6.69E-04	-2.76E-03	-4.36E-03	-4.45E-03	-3.15E-03	-5.86E-04	3.20E-03
2	-1.31E-02	-4.16E-03	-3.83E-03	-4.72E-03	-5.27E-03	-5.06E-03	-3.92E-03	-1.72E-03	1.51E-03	5.80E-03
3	-1.97E-02	-1.80E-03	1.02E-03	3.66E-04	-7.69E-04	-1.40E-03	-1.14E-03	1.76E-04	2.58E-03	6.08E-03
4	-1.59E-02	6.32E-03	9.29E-03	7.22E-03	4.18E-03	1.59E-03	-4.10E-05	-4.73E-04	2.96E-04	2.31E-03
5	-1.68E-02	9.44E-03	1.29E-02	9.75E-03	4.97E-03	4.21E-04	-3.17E-03	-5.52E-03	-6.56E-03	-6.27E-03

High	1	2	3	4	5	6	7	8	9	10
6	-2.13E-02	1.49E-02	1.77E-02	1.07E-02	2.25E-03	-4.48E-03	-8.03E-03	-7.77E-03	-3.41E-03	5.26E-03
7	-1.76E-02	1.27E-02	1.43E-02	7.52E-03	-2.25E-04	-6.05E-03	-8.71E-03	-7.59E-03	-2.43E-03	7.00E-03
8	-1.26E-02	1.22E-02	1.23E-02	5.59E-03	-1.65E-03	-6.80E-03	-8.76E-03	-6.97E-03	-1.17E-03	8.86E-03
9	-8.80E-03	1.17E-02	1.07E-02	4.07E-03	-2.68E-03	-7.24E-03	-8.59E-03	-6.21E-03	1.15E-04	1.06E-02
10	-8.27E-03	9.64E-03	8.39E-03	2.13E-03	-4.00E-03	-7.90E-03	-8.64E-03	-5.72E-03	1.10E-03	1.20E-02

Appendix 8: Dose Fit Diagnostics

The following tables represent, for fractional difference as described in appendices 6 and 7, the average fractional difference, the standard deviation of the fractional differences, the maximum fractional difference and the minimum fractional difference between the analytical dose fit and the buildup data for each configuration with incident photons of the following energies: 65 keV, 100 keV 500 keV, 1 MeV, 2 MeV, 6 MeV and 10 MeV. Full refers to a fit of all 100 thicknesses, Low refers to a fit of 1-10 mfp of the first material followed by 1-5 mfp of the second material and High refers to a fit of 1-10 mfp of the first material followed by 6-10 mfp of the second material.

Aluminum followed by lead

Full		Al-Pb		
Energy	Average	St. Dev	Max	Min
65	1.62E-02	2.36E-02	9.91E-02	3.40E-05
100 (log)	7.31E-02	9.60E-02	2.72E-01	1.86E-04
500	1.19E-02	1.83E-02	7.51E-02	4.37E-04
1	1.36E-02	2.12E-02	8.63E-02	5.85E-05
2	1.54E-02	2.61E-02	1.46E-01	2.53E-04
6	2.55E-02	3.92E-02	1.37E-01	7.15E-04
10	3.27E-02	4.86E-02	1.59E-01	3.14E-04

Low		Al-Pb		
Energy	Average	St. Dev	Max	Min
65	9.49E-03	1.20E-02	3.23E-02	2.59E-04
100 (log)	3.80E-02	4.74E-02	1.11E-01	3.66E-03
500	1.01E-02	1.26E-02	3.70E-02	2.08E-04
1	9.97E-03	1.32E-02	3.36E-02	2.10E-04
2	8.66E-03	1.31E-02	5.11E-02	7.26E-04
6	1.10E-02	1.54E-02	3.57E-02	6.32E-04
10	1.51E-02	2.05E-02	4.76E-02	4.57E-04

High		Al-Pb		
Energy	Average	St. Dev	Max	Min
65	1.19E-02	1.37E-02	3.16E-02	1.07E-03
100 (log)	1.14E-01	1.71E-02	1.46E-01	6.94E-02
500	5.78E-03	6.87E-03	1.66E-02	2.68E-04
1	9.05E-03	1.11E-02	2.64E-02	6.99E-06
2	5.75E-03	7.25E-03	1.93E-02	6.54E-04
6	2.42E-03	3.32E-03	1.05E-02	3.62E-05
10	5.53E-03	8.09E-03	3.23E-02	1.37E-04

Lead followed by aluminum

Full		Pb-Al			
Energy	Average	St. Dev	Max	Min	
65	5.79E-02	8.43E-03	5.79E-02	6.06E-05	
100 (log)	4.67E-02	5.77E-02	1.22E-01	7.75E-04	
500	1.88E-02	3.04E-02	9.79E-02	1.64E-04	
1	1.89E-02	3.14E-02	1.12E-01	6.14E-05	
2	1.66E-02	2.84E-02	1.22E-01	5.16E-05	
6	8.82E-03	1.31E-02	4.76E-02	9.59E-05	
10	1.61E-02	2.27E-02	7.51E-02	4.59E-04	

Low		Pb-Al			
Energy	Average	St. Dev	Max	Min	
65	4.60E-03	7.56E-03	3.50E-02	4.03E-05	
100 (log)	1.25E-02	1.56E-02	3.95E-02	8.17E-04	
500	1.13E-02	1.85E-02	6.97E-02	3.01E-04	
1	1.10E-02	1.76E-02	5.62E-02	3.41E-04	
2	9.33E-03	1.45E-02	4.19E-02	9.87E-05	
6	4.87E-03	7.70E-03	3.52E-02	3.72E-04	
10	9.64E-03	1.32E-02	4.69E-02	3.68E-04	

High		Pb-Al			
Energy	Average	St. Dev	Max	Min	
65	3.24E-03	5.23E-03	2.43E-02	1.96E-04	
100 (log)	1.12E-01	2.08E-02	1.57E-01	7.70E-02	
500	5.49E-03	9.72E-03	3.82E-02	5.44E-06	
1	3.45E-03	5.41E-03	2.16E-02	3.17E-05	
2	3.01E-03	4.31E-03	1.61E-02	6.33E-06	
6	5.16E-03	6.18E-03	1.72E-02	2.41E-04	
10	8.40E-03	1.09E-02	3.46E-02	1.48E-04	

Polyethylene followed by lead

Full		Poly-Pb			
Energy	Average	St. Dev	Max	Min	
65	2.42E-02	3.26E-02	1.33E-01	3.49E-04	
100 (log)	9.87E-02	1.27E-01	3.44E-01	6.66E-02	
500	1.18E-02	1.80E-02	7.45E-02	1.72E-04	
1	1.36E-02	2.10E-02	8.53E-02	8.32E-05	
2	1.54E-02	2.63E-02	1.47E-01	2.44E-04	
6	2.69E-02	4.10E-02	1.41E-01	2.66E-04	
10	3.46E-02	5.13E-02	1.66E-01	2.81E-04	

Polyethylene followed by lead continued

Low		Poly-Pb			
Energy	Average	St. Dev	Max	Min	
65	1.21E-02	1.54E-02	3.82E-02	3.75E-04	
100 (log)	5.24E-02	6.66E-02	1.54E-01	1.43E-04	
500	1.01E-02	1.26E-02	3.64E-02	2.57E-04	
1	9.99E-03	1.32E-02	3.36E-02	1.84E-04	
2	8.67E-03	1.31E-02	5.12E-02	8.87E-04	
6	1.16E-02	1.62E-02	3.74E-02	3.30E-05	
10	1.59E-02	2.18E-02	4.81E-02	5.78E-05	

High		Poly-Pb			
Energy	Average	St. Dev	Max	Min	
65	1.13E-02	1.52E-02	5.42E-02	1.40E-04	
100 (log)	1.19E-01	5.40E-02	2.83E-01	2.08E-02	
500	4.92E-03	5.84E-03	1.36E-02	1.42E-04	
1	9.06E-03	1.11E-02	2.64E-02	3.76E-06	
2	5.53E-03	7.06E-03	1.93E-02	2.92E-04	
6	2.46E-03	3.37E-03	1.10E-02	1.03E-04	
10	4.82E-03	7.11E-03	2.93E-02	1.89E-05	

Lead followed by polyethylene

Full		Pb-Poly			
Energy	Average	St. Dev	Max	Min	
65	6.53E-02	1.48E-01	6.93E-01	4.67E-04	
100 (log)	4.79E-02	6.70E-02	3.29E-01	2.88E-04	
500	2.97E-02	5.02E-02	1.85E-01	5.79E-04	
1	2.13E-02	3.50E-02	1.21E-01	2.76E-04	
2	1.70E-02	2.90E-02	1.16E-01	1.06E-04	
6	1.03E-02	1.47E-02	5.01E-02	4.45E-05	
10	1.94E-02	2.61E-02	8.96E-02	5.13E-05	

Low		Pb-Poly			
Energy	Average	St. Dev	Max	Min	
65	4.58E-02	1.05E-01	4.81E-01	1.40E-04	
100 (log)	1.74E-02	2.29E-02	6.74E-02	2.79E-04	
500	1.81E-02	3.31E-02	1.19E-01	3.00E-04	
1	1.29E-02	2.10E-02	6.83E-02	5.24E-05	
2	9.70E-03	1.52E-02	4.74E-02	1.35E-04	
6	4.94E-03	7.68E-03	3.49E-02	1.59E-04	
10	1.04E-02	1.52E-02	6.03E-02	1.22E-04	

Lead followed by polyethylene Continued

High		Pb-Poly		
Energy	Average	St. Dev	Max	Min
65	3.80E-02	9.07E-02	4.44E-01	6.01E-04
100 (log)	6.00E-02	6.79E-02	1.33E-01	5.41E-03
500	1.03E-02	2.08E-02	9.58E-02	1.68E-04
1	4.27E-03	7.20E-03	2.59E-02	2.10E-04
2	3.17E-03	4.49E-03	1.61E-02	4.85E-06
6	8.20E-03	9.65E-03	2.50E-02	1.13E-04
10	1.12E-02	1.41E-02	3.80E-02	7.02E-04

Stainless steel followed by lead

Full		SS-Pb		
Energy	Average	St. Dev	Max	Min
65	3.68E-03	5.32E-03	1.72E-02	7.93E-06
100 (log)	3.25E-02	4.34E-02	1.66E-01	8.79E-04
500	1.22E-02	1.88E-02	7.60E-02	2.67E-05
1	1.37E-02	2.15E-02	8.83E-02	1.63E-04
2	1.53E-02	2.59E-02	1.44E-01	5.94E-04
6	2.34E-02	3.64E-02	1.31E-01	8.36E-04
10	3.02E-02	4.44E-02	1.40E-01	4.95E-04

Low		SS-Pb		
Energy	Average	St. Dev	Max	Min
65	2.44E-03	3.33E-03	1.01E-02	9.52E-05
100 (log)	1.80E-02	2.29E-02	7.68E-02	6.00E-04
500	9.79E-03	1.24E-02	3.70E-02	1.82E-04
1	9.79E-03	1.30E-02	3.32E-02	2.13E-04
2	8.58E-03	1.29E-02	5.09E-02	6.36E-04
6	1.01E-02	1.42E-02	3.36E-02	3.64E-04
10	1.29E-02	1.79E-02	4.13E-02	8.38E-05

High		SS-Pb		
Energy	Average	St. Dev	Max	Min
65	1.72E-03	2.18E-03	5.38E-03	1.70E-05
100 (log)	1.07E-01	1.70E-02	1.30E-01	4.34E-02
500	7.62E-03	9.11E-03	2.12E-02	3.01E-04
1	9.01E-03	1.10E-02	2.64E-02	2.35E-06
2	5.92E-03	7.35E-03	1.91E-02	5.25E-04
6	2.30E-03	3.06E-03	8.60E-03	6.14E-05
10	6.33E-03	9.19E-03	3.41E-02	2.05E-04

Lead followed by stainless steel

Full		Pb-SS		
Energy	Average	St. Dev	Max	Min
65	2.30E-03	3.23E-03	9.68E-03	2.67E-05
100 (log)	7.26E-02	9.05E-02	2.74E-01	1.99E-03
500	1.48E-02	2.35E-02	7.17E-02	2.14E-04
1	1.76E-02	2.94E-02	1.10E-01	1.26E-04
2	1.65E-02	2.84E-02	1.26E-01	7.65E-05
6	9.32E-03	1.54E-02	7.63E-02	3.50E-05
10	1.18E-02	1.80E-02	6.31E-02	6.62E-05

Low		Pb-SS		
Energy	Average	St. Dev	Max	Min
65	1.29E-03	1.74E-03	4.32E-03	4.73E-05
100 (log)	3.91E-02	4.47E-02	8.98E-02	5.21E-03
500	8.36E-03	1.34E-02	4.87E-02	5.59E-05
1	1.58E-01	2.77E-01	1.46E+00	3.70E-04
2	9.24E-03	1.42E-02	3.87E-02	1.97E-04
6	5.52E-03	8.55E-03	3.48E-02	4.14E-05
10	6.52E-03	9.59E-03	3.61E-02	5.57E-05

High		Pb-SS		
Energy	Average	St. Dev	Max	Min
65	5.71E-04	7.54E-04	2.41E-03	1.73E-05
100 (log)	7.31E-02	8.53E-02	2.79E-01	2.63E-03
500	3.74E-03	6.11E-03	2.60E-02	7.38E-05
1	3.05E-03	4.63E-03	1.87E-02	3.90E-05
2	2.91E-03	4.16E-03	1.60E-02	1.66E-05
6	1.12E-03	1.40E-03	4.30E-03	6.09E-05
10	5.14E-03	6.59E-03	2.46E-02	1.08E-04

Aluminum followed by stainless steel

Full		Al-SS		
Energy	Average	St. Dev	Max	Min
65	1.63E-02	2.44E-02	1.10E-01	1.79E-04
100	1.90E-02	3.00E-02	1.31E-01	1.00E-04
500	2.17E-02	3.92E-02	2.28E-01	3.11E-04
1	2.08E-02	3.87E-02	2.34E-01	1.25E-04
2	1.84E-02	3.36E-02	2.02E-01	2.43E-04
6	1.65E-02	2.78E-02	1.35E-01	1.45E-04
10	1.52E-02	2.44E-02	9.79E-02	6.52E-05

Aluminum followed by stainless steel, continued

Low		Al-SS		
Energy	Average	St. Dev	Max	Min
65	9.13E-03	1.19E-02	3.42E-02	5.24E-04
100	1.27E-02	1.68E-02	4.65E-02	3.03E-04
500	1.19E-02	1.87E-02	7.47E-02	4.66E-04
1	1.16E-02	1.81E-02	6.90E-02	2.75E-04
2	1.02E-02	1.59E-02	6.00E-02	1.85E-04
6	8.75E-03	1.30E-02	4.00E-02	4.32E-04
10	7.65E-03	1.12E-02	2.82E-02	2.31E-04

High		Al-SS		
Energy	Average	St. Dev	Max	Min
65	1.18E-02	1.38E-02	2.78E-02	1.49E-04
100	1.36E-02	1.65E-02	3.97E-02	1.00E-04
500	3.84E-03	5.52E-03	2.03E-02	1.37E-04
1	1.58E-03	2.29E-03	6.91E-03	2.68E-05
2	1.36E-03	1.83E-03	5.00E-03	4.33E-05
6	1.69E-03	2.32E-03	8.00E-03	5.12E-05
10	1.74E-03	2.46E-03	8.89E-03	1.04E-04

Stainless steel followed by aluminum

Full		SS-Al		
Energy	Average	St. Dev	Max	Min
65	9.98E-03	1.53E-02	5.98E-02	6.77E-05
100	1.97E-02	3.09E-02	1.03E-01	9.08E-05
500	2.97E-02	4.92E-02	1.88E-01	1.42E-04
1	2.39E-02	4.25E-02	2.31E-01	2.36E-05
2	1.79E-02	3.28E-02	1.99E-01	3.80E-05
6	1.07E-02	1.87E-02	1.07E-01	1.43E-05
10	9.33E-03	1.49E-02	6.91E-02	1.29E-05

Low		SS-Al		
Energy	Average	St. Dev	Max	Min
65	5.52E-03	8.68E-03	3.73E-02	3.31E-05
100	1.11E-02	1.78E-02	7.22E-02	1.50E-04
500	1.57E-02	2.35E-02	6.80E-02	5.38E-04
1	1.28E-02	1.94E-02	5.29E-02	5.53E-05
2	1.00E-02	1.56E-02	5.73E-02	2.47E-04
6	6.42E-03	1.00E-02	4.18E-02	1.78E-04
10	5.70E-03	8.64E-03	3.56E-02	2.45E-05

Stainless steel followed by aluminum, continued

High		SS-Al		
Energy	Average	St. Dev	Max	Min
65	3.43E-03	5.49E-03	2.52E-02	1.13E-04
100	6.31E-03	1.08E-02	4.60E-02	3.81E-06
500	5.82E-03	8.59E-03	3.29E-02	4.17E-04
1	3.14E-03	4.54E-03	1.83E-02	1.97E-04
2	1.50E-03	2.06E-03	7.31E-03	1.47E-05
6	2.22E-03	2.86E-03	9.82E-03	2.80E-04
10	4.76E-03	5.66E-03	1.52E-02	6.69E-06

Polyethylene followed by stainless steel

Full		Poly-SS		
Energy	Average	St. Dev	Max	Min
65	2.43E-02	3.25E-02	1.27E-01	2.03E-04
100	1.95E-02	2.95E-02	1.20E-01	4.59E-04
500	2.16E-02	3.86E-02	2.24E-01	1.15E-04
1	2.07E-02	3.26E-02	2.33E-01	3.09E-05
2	1.86E-02	3.39E-02	2.02E-01	8.31E-05
6	1.73E-02	2.88E-02	1.31E-01	2.01E-04
10	1.70E-02	2.62E-02	9.74E-02	3.82E-05

Low		Poly-SS		
Energy	Average	St. Dev	Max	Min
65	1.31E-02	1.65E-02	4.25E-02	1.22E-03
100	1.49E-02	1.90E-02	5.57E-02	7.23E-04
500	1.18E-02	1.88E-02	7.62E-02	5.07E-04
1	1.16E-02	1.38E-02	6.93E-02	1.82E-04
2	1.03E-02	1.60E-02	5.98E-02	1.75E-04
6	9.19E-03	1.36E-02	3.74E-02	5.97E-04
10	8.03E-03	8.31E-03	2.81E-02	1.92E-05

High		Poly-SS		
Energy	Average	St. Dev	Max	Min
65	1.31E-02	1.75E-02	6.20E-02	7.43E-05
100	1.21E-02	1.51E-02	4.38E-02	2.91E-04
500	4.74E-03	6.81E-03	2.53E-02	6.38E-05
1	1.73E-03	2.50E-03	7.39E-03	8.62E-05
2	1.45E-03	1.93E-03	4.99E-03	8.86E-05
6	1.68E-03	2.35E-03	8.11E-03	5.94E-05
10	1.60E-03	2.29E-03	8.14E-03	1.53E-05

Stainless steel followed by polyethylene

Full		SS-Poly		
Energy	Average	St. Dev	Max	Min
65 (log)	1.04E-02	1.52E-02	8.17E-02	1.70E-05
100 (log)	1.98E-02	2.88E-02	1.57E-01	1.21E-04
500(log)	4.53E-02	7.45E-02	2.36E-01	4.43E-06
1	7.98E-02	1.49E-01	9.80E-01	4.88E-03
2	1.85E-02	3.32E-02	1.94E-01	8.33E-05
6	9.55E-03	1.53E-02	7.08E-02	1.50E-04
10	1.03E-02	1.44E-02	5.04E-02	3.59E-04

Low		SS-Poly		
Energy	Average	St. Dev	Max	Min
65log	5.62E-03	7.71E-03	3.00E-02	1.14E-04
100 (log)	1.10E-02	1.52E-02	5.89E-02	3.08E-04
500(log)	2.77E-02	4.63E-02	1.61E-01	1.34E-04
1	1.54E-02	2.37E-02	7.25E-02	1.96E-04
2	1.02E-02	1.58E-02	5.02E-02	4.26E-05
6	5.86E-03	9.09E-03	3.94E-02	1.93E-04
10	5.82E-03	8.57E-03	3.16E-02	8.34E-05

High		SS-Poly		
Energy	Average	St. Dev	Max	Min
65	5.28E-01	2.41E-01	8.31E-01	7.17E-02
100 (log)	3.74E-02	4.24E-02	6.66E-02	7.75E-04
500(log)	1.16E-02	2.10E-02	9.57E-02	6.57E-04
1	5.51E-03	7.94E-03	2.74E-02	2.90E-05
2	2.96E-03	4.22E-03	1.64E-02	3.35E-04
6	5.16E-03	6.09E-03	1.59E-02	1.78E-04
10	8.13E-03	9.54E-03	2.20E-02	1.55E-04

Appendix 9: Exposure Fit Diagnostics

Similarly to appendix 8, the following tables represent, for fractional difference as described in Appendices 6 and 7, the average fractional difference, the standard deviation of the fractional differences, the maximum fractional difference and the minimum fractional difference between the analytical exposure fit and the buildup data for each configuration with incident photons of the following energies: 65 keV, 100 keV 500 keV, 1 MeV, 2 MeV, 6 MeV and 10 MeV. Full refers to a fit of all 100 thicknesses, Low refers to a fit of 1-10 mfp of the first material followed by 1-5 mfp of the second material and High refers to a fit of 1-10 mfp of the first material followed by 6-10 mfp of the second material.

Aluminum followed by lead

Full	Al-Pb			
Energy	Average	St. Dev	Max	Min
65	1.67E-02	2.41E-02	9.99E-02	4.91E-06
100 (log)	7.13E-02	9.36E-02	2.61E-01	1.93E-03
500	1.18E-02	1.81E-02	7.41E-02	4.37E-04
1	1.34E-02	2.09E-02	8.50E-02	9.83E-05
2	1.54E-02	2.61E-02	1.46E-01	2.42E-05
6	2.53E-02	3.89E-02	1.36E-01	6.21E-04
10	3.25E-02	4.83E-02	1.59E-01	3.28E-04

Low	Al-Pb			
Energy	Average	St. Dev	Max	Min
65	9.95E-03	1.25E-02	3.34E-02	2.78E-06
100 (log)	3.80E-02	4.74E-02	1.07E-01	1.07E-03
500	9.97E-03	1.25E-02	3.65E-02	2.57E-04
1	9.79E-03	1.29E-02	3.28E-02	1.78E-04
2	8.62E-03	1.30E-02	5.09E-02	7.43E-04
6	1.09E-02	1.52E-02	3.54E-02	6.20E-04
10	1.50E-02	2.03E-02	4.67E-02	6.56E-04

High	Al-Pb			
Energy	Average	St. Dev	Max	Min
65	1.24E-02	1.43E-02	3.43E-02	6.94E-04
100 (log)	4.13E-02	3.03E-02	9.29E-02	8.83E-04
500	5.78E-03	6.86E-03	1.64E-02	3.61E-04
1	8.89E-03	1.09E-02	2.58E-02	2.93E-05
2	5.57E-03	7.04E-03	1.89E-02	6.02E-04
6	2.40E-03	3.29E-03	1.04E-02	2.68E-05
10	5.46E-03	7.96E-03	3.17E-02	1.42E-04

Lead followed by aluminum

Full		Pb-Al		
Energy	Average	St. Dev	Max	Min
65	8.45E-03	1.31E-02	5.84E-02	8.00E-06
100 (log)	4.63E-02	5.71E-02	1.21E-01	3.17E-04
500	1.79E-02	2.87E-02	8.97E-02	7.43E-05
1	1.83E-02	3.04E-02	1.11E-01	4.27E-05
2	1.63E-02	2.79E-02	1.23E-01	1.96E-06
6	8.71E-03	1.29E-02	4.69E-02	1.27E-05
10	1.81E-02	2.34E-02	7.65E-02	2.98E-04

Low		Pb-Al		
Energy	Average	St. Dev	Max	Min
65	4.63E-03	7.62E-03	3.53E-02	1.96E-05
100 (log)	1.22E-02	1.52E-02	3.88E-02	8.89E-04
500	1.06E-02	1.71E-02	6.42E-02	3.09E-04
1	1.71E-01	3.00E-01	1.71E-01	1.46E-04
2	9.13E-03	1.41E-02	3.97E-02	1.64E-04
6	4.81E-03	7.58E-03	3.46E-02	3.75E-04
10	8.43E-03	1.09E-02	3.45E-02	2.61E-04

High		Pb-Al		
Energy	Average	St. Dev	Max	Min
65	3.27E-03	5.28E-03	2.45E-02	1.87E-04
100 (log)	1.42E-01	2.16E-02	1.88E-01	1.04E-01
500	5.08E-03	8.83E-03	3.53E-02	9.58E-06
1	3.27E-03	5.07E-03	2.02E-02	5.46E-05
2	2.92E-03	4.15E-03	1.56E-02	3.02E-06
6	5.15E-03	6.19E-03	1.76E-02	2.06E-04
10	1.58E-02	2.22E-02	7.35E-02	3.82E-04

Polyethylene followed by lead

Full		Poly-Pb		
Energy	Average	St. Dev	Max	Min
65	2.65E-02	3.54E-02	1.42E-01	2.92E-04
100 (log)	1.00E-01	1.27E-01	3.31E-01	3.32E-03
500	1.16E-02	1.78E-02	7.34E-02	1.84E-04
1	1.34E-02	2.07E-02	8.41E-02	7.51E-05
2	1.54E-02	2.62E-02	1.47E-01	1.82E-04
6	2.67E-02	4.07E-02	1.40E-01	3.17E-04
10	3.44E-02	5.10E-02	1.65E-01	1.74E-04

Polyethylene followed by lead, continued

Low		Poly-Pb		
Energy	Average	St. Dev	Max	Min
65	1.31E-02	1.66E-02	4.01E-02	1.79E-04
100 (log)	5.38E-02	6.94E-02	1.63E-01	1.54E-04
500	1.00E-02	1.25E-02	3.60E-02	3.08E-04
1	9.80E-03	1.29E-02	3.29E-02	1.71E-04
2	8.63E-03	1.31E-02	5.10E-02	9.05E-04
6	1.15E-02	1.60E-02	3.71E-02	7.03E-05
10	1.58E-02	2.17E-02	4.77E-02	8.70E-06

High		Poly-Pb		
Energy	Average	St. Dev	Max	Min
65	1.19E-02	1.61E-02	5.67E-02	1.13E-04
100 (log)	6.21E-02	6.73E-02	1.78E-01	5.81E-04
500	4.93E-03	5.83E-03	1.38E-02	1.35E-04
1	8.91E-03	1.09E-02	2.59E-02	6.08E-05
2	5.35E-03	6.86E-03	1.89E-02	1.05E-04
6	2.44E-03	3.34E-03	1.09E-02	9.78E-05
10	4.75E-03	6.99E-03	2.87E-02	1.10E-05

Lead followed by polyethylene, continued:

Full		Pb-Poly		
Energy	Average	St. Dev	Max	Min
65	8.81E-02	2.11E-01	1.04E+00	2.55E-04
100 (log)	5.01E-02	6.93E-02	3.26E-01	6.59E-04
500	2.81E-02	4.64E-02	1.67E-01	3.71E-04
1	1.33E-01	2.18E-01	1.14E+00	9.12E-04
2	1.66E-02	2.83E-02	1.17E-01	7.28E-05
6	1.01E-02	1.43E-02	4.86E-02	4.76E-05
10	1.91E-02	2.56E-02	8.69E-02	9.38E-05

Low		Pb-Poly		
Energy	Average	St. Dev	Max	Min
65	6.48E-02	1.57E-01	7.28E-01	3.26E-04
100 (log)	1.84E-02	2.40E-02	6.36E-02	2.09E-04
500	3.01E-02	1.69E-02	1.07E-01	3.20E-05
1	1.21E-02	1.96E-02	6.21E-02	6.79E-05
2	9.38E-03	1.46E-02	4.42E-02	1.74E-04
6	4.83E-03	7.52E-03	3.42E-02	1.88E-04
10	9.93E-03	1.45E-02	5.75E-02	1.77E-04

Lead followed by polyethylene, continued

High		Pb-Poly		
Energy	Average	St. Dev	Max	Min
65	5.61E-02	1.38E-01	6.69E-01	4.19E-04
100 (log)	2.29E-01	1.77E-01	4.54E-01	9.05E-04
500	9.57E-03	1.88E-02	8.56E-02	1.43E-04
1	3.97E-03	6.57E-03	2.26E-02	1.97E-04
2	3.06E-03	4.32E-03	1.56E-02	3.54E-06
6	8.14E-03	9.57E-03	2.43E-02	1.29E-04
10	1.13E-02	1.41E-02	3.75E-02	7.72E-04

Stainless steel followed by lead

Full		SS-Pb		
Energy	Average	St. Dev	Max	Min
65	2.47E-03	3.37E-03	1.02E-02	3.73E-05
100 (log)	3.22E-02	4.28E-02	1.55E-01	1.07E-03
500	1.21E-02	1.86E-02	7.51E-02	8.95E-05
1	1.35E-02	2.12E-02	8.70E-02	3.92E-04
2	1.53E-02	2.59E-02	1.44E-01	4.05E-04
6	2.32E-02	3.61E-02	1.30E-01	6.64E-04
10	3.00E-02	4.40E-02	1.39E-01	4.10E-04

Low		SS-Pb		
Energy	Average	St. Dev	Max	Min
65	1.67E-03	2.11E-03	5.21E-03	6.61E-05
100 (log)	1.78E-02	2.28E-02	7.48E-02	1.24E-04
500	9.68E-03	1.22E-02	3.65E-02	2.17E-04
1	9.62E-03	1.28E-02	3.28E-02	2.53E-04
2	8.54E-03	1.29E-02	5.08E-02	6.53E-04
6	1.00E-02	1.41E-02	3.33E-02	2.98E-04
10	1.28E-02	1.77E-02	4.06E-02	8.41E-05

High		SS-Pb		
Energy	Average	St. Dev	Max	Min
65	3.62E-03	5.25E-03	1.73E-02	3.97E-05
100 (log)	3.92E-02	4.45E-02	1.17E-01	4.73E-05
500	7.58E-03	9.05E-03	2.13E-02	2.82E-05
1	8.86E-03	1.08E-02	2.60E-02	1.14E-05
2	5.74E-03	7.15E-03	1.87E-02	6.18E-04
6	2.29E-03	3.04E-03	8.58E-03	7.48E-05
10	6.26E-03	9.08E-03	3.37E-02	2.08E-04

Lead followed by stainless steel

Full		Pb-SS		
Energy	Average	St. Dev	Max	Min
65	2.29E-03	3.22E-03	9.65E-03	2.09E-05
100 (log)	7.16E-02	8.94E-02	2.72E-01	7.64E-04
500	1.24E-01	1.94E-01	9.12E-01	1.55E-03
1	1.72E-02	2.88E-02	1.08E-01	2.58E-05
2	1.63E-02	2.81E-02	1.26E-01	1.04E-04
6	9.22E-03	1.52E-02	7.53E-02	1.62E-05
10	6.42E-03	9.43E-03	3.55E-02	8.82E-05

Low		Pb-SS		
Energy	Average	St. Dev	Max	Min
65	1.29E-03	1.73E-03	4.31E-03	4.93E-05
100 (log)	3.86E-02	4.42E-02	8.36E-02	3.95E-03
500	8.17E-03	1.30E-02	4.67E-02	1.90E-05
1	9.98E-03	1.55E-02	4.55E-02	1.61E-04
2	9.11E-03	1.40E-02	3.74E-02	1.06E-04
6	5.45E-03	8.43E-03	3.43E-02	1.23E-06
10	5.20E-03	6.62E-03	2.44E-02	2.44E-02

High		Pb-SS		
Energy	Average	St. Dev	Max	Min
65	5.73E-04	7.56E-04	2.40E-03	1.72E-05
100 (log)	7.37E-02	8.72E-02	2.85E-01	6.41E-04
500	3.61E-03	5.86E-03	2.49E-02	3.11E-05
1	2.95E-03	4.46E-03	1.80E-02	1.27E-05
2	2.83E-03	4.05E-03	1.56E-02	3.44E-05
6	1.11E-03	1.41E-03	4.07E-03	2.30E-05
10	1.17E-02	1.77E-02	6.18E-02	2.07E-05

Aluminum followed by stainless steel

Full		Al-SS		
Energy	Average	St. Dev	Max	Min
65	1.64E-02	2.46E-02	1.11E-01	4.28E-04
100	1.89E-02	2.98E-02	1.30E-01	1.52E-05
500	2.13E-02	3.85E-02	2.23E-01	1.16E-04
1	2.04E-02	3.78E-02	2.28E-01	4.95E-05
2	1.82E-02	3.32E-02	1.98E-01	2.37E-04
6	1.63E-02	2.75E-02	1.33E-01	8.91E-05
10	1.50E-02	2.41E-02	9.58E-02	3.40E-05

Aluminum followed by stainless steel, continued

Low		Al-SS		
Energy	Average	St. Dev	Max	Min
65	9.27E-03	1.20E-02	3.47E-02	5.27E-04
100	1.26E-02	1.67E-02	4.62E-02	2.43E-04
500	1.17E-02	1.83E-02	7.24E-02	4.98E-04
1	1.14E-02	1.77E-02	6.71E-02	2.93E-04
2	1.01E-02	1.57E-02	5.91E-02	2.33E-04
6	8.65E-03	1.28E-02	3.93E-02	4.56E-04
10	7.56E-03	1.10E-02	2.77E-02	2.08E-04

High		Al-SS		
Energy	Average	St. Dev	Max	Min
65	1.21E-02	1.41E-02	2.81E-02	8.45E-05
100	1.36E-02	1.64E-02	3.95E-02	6.30E-04
500	3.46E-03	4.97E-03	1.79E-02	7.90E-05
1	1.51E-03	2.16E-03	6.52E-03	5.64E-05
2	1.35E-03	1.82E-03	4.93E-03	3.26E-05
6	1.67E-03	2.28E-03	7.84E-03	8.62E-05
10	1.71E-03	2.42E-03	8.69E-03	6.09E-05

Stainless steel followed by aluminum

Full		SS-Al		
Energy	Average	St. Dev	Max	Min
65	1.00E-02	1.54E-02	6.04E-02	6.97E-05
100	1.95E-02	3.05E-02	1.01E-01	1.75E-04
500	2.84E-02	4.74E-02	1.85E-01	8.86E-05
1	6.19E-02	1.23E-01	8.41E-01	1.03E-03
2	1.76E-02	3.21E-02	1.95E-01	4.83E-05
6	1.06E-02	1.84E-02	1.05E-01	1.77E-04
10	9.15E-03	1.46E-02	6.82E-02	4.44E-05

Low		SS-Al		
Energy	Average	St. Dev	Max	Min
65	5.54E-03	8.73E-03	3.77E-02	4.49E-05
100	1.09E-02	1.75E-02	7.08E-02	1.38E-04
500	1.50E-02	2.22E-02	6.12E-02	8.24E-05
1	1.24E-02	1.88E-02	5.40E-02	2.13E-05
2	9.82E-03	1.53E-02	5.67E-02	3.40E-04
6	6.33E-03	9.83E-03	4.08E-02	1.58E-04
10	5.57E-03	8.43E-03	3.47E-02	2.73E-05

Stainless steel followed by aluminum, continued

High		SS-Al		
Energy	Average	St. Dev	Max	Min
65	3.46E-03	5.54E-03	2.54E-02	1.26E-04
100	6.22E-03	1.06E-02	4.51E-02	5.98E-06
500	5.30E-03	7.75E-03	2.99E-02	4.44E-04
1	2.84E-03	4.07E-03	1.63E-02	1.93E-04
2	1.41E-03	1.91E-03	6.48E-03	1.58E-05
6	2.12E-03	2.73E-03	9.41E-03	2.27E-04
10	4.55E-03	2.73E-05	1.48E-02	7.82E-05

Polyethylene followed by stainless steel

Full		Poly-SS		
Energy	Average	St. Dev	Max	Min
65	2.55E-02	3.38E-02	1.30E-01	9.07E-05
100	1.94E-02	2.93E-02	1.18E-01	4.60E-04
500	2.12E-02	3.79E-02	2.20E-01	2.73E-04
1	2.03E-02	3.76E-02	2.27E-01	5.66E-05
2	1.84E-02	3.34E-02	1.98E-01	6.34E-05
6	1.71E-02	2.85E-02	1.29E-01	1.47E-04
10	1.69E-02	2.59E-02	9.59E-02	2.38E-05

Low		Poly-SS		
Energy	Average	St. Dev	Max	Min
65	1.37E-02	1.72E-02	4.37E-02	1.94E-03
100	1.49E-02	1.89E-02	5.54E-02	7.24E-04
500	1.16E-02	1.84E-02	7.37E-02	5.13E-04
1	1.13E-02	1.76E-02	6.74E-02	1.98E-04
2	1.02E-02	1.58E-02	5.90E-02	2.27E-04
6	9.10E-03	1.34E-02	3.69E-02	5.39E-04
10	7.95E-03	1.15E-02	2.78E-02	2.88E-06

High		Poly-SS		
Energy	Average	St. Dev	Max	Min
65	1.37E-02	1.83E-02	6.42E-02	4.22E-04
100	1.23E-02	1.54E-02	4.40E-02	2.63E-04
500	4.24E-03	6.10E-03	2.24E-02	3.10E-05
1	1.61E-03	2.33E-03	6.93E-03	6.23E-05
2	1.44E-03	1.91E-03	4.91E-03	1.04E-04
6	1.66E-03	2.32E-03	7.94E-03	2.21E-05
10	1.57E-03	2.25E-03	7.95E-03	1.89E-05

Stainless steel followed by polyethylene

Full		SS-Poly		
Energy	Average	St. Dev	Max	Min
65 (log)	1.04E-02	1.52E-02	8.28E-02	1.95E-05
100 (log)	2.04E-02	2.97E-02	1.60E-01	8.73E-04
500 (log)	4.53E-02	7.45E-02	2.36E-01	4.43E-06
1	7.98E-02	1.49E-01	9.80E-01	4.88E-03
2	1.80E-02	3.23E-02	1.90E-01	6.62E-04
6	9.36E-03	1.50E-02	7.04E-02	1.28E-04
10	9.98E-03	1.40E-02	4.87E-02	5.64E-05

Low		SS-Poly		
Energy	Average	St. Dev	Max	Min
65 (log)	5.62E-03	7.71E-03	3.00E-02	1.14E-04
100 (log)	1.13E-02	1.57E-02	5.85E-02	2.33E-04
500(log)	2.77E-02	4.63E-02	1.61E-01	1.34E-04
1	1.47E-02	2.22E-02	6.52E-02	7.01E-04
2	9.91E-03	1.54E-02	5.04E-02	8.52E-05
6	5.73E-03	8.87E-03	3.84E-02	2.62E-04
10	5.61E-03	8.26E-03	3.10E-02	4.10E-05

High		SS-Poly		
Energy	Average	St. Dev	Max	Min
65(log)	2.06E-01	8.73E-02	3.14E-01	3.22E-02
100 (log)	1.65E-01	1.32E-01	3.26E-01	2.07E-02
500(log)	1.16E-02	2.10E-02	9.57E-02	6.57E-04
1	5.14E-03	7.35E-03	2.53E-02	1.53E-04
2	2.62E-03	3.77E-03	1.48E-02	6.99E-05
6	4.92E-03	5.81E-03	1.57E-02	2.34E-04
10	7.91E-03	9.25E-03	2.13E-02	1.15E-04

Appendix 10: Sample NJOY input File for Polyethylene and Stainless Steel

```

reconr 1.38799E+04
30 31 1.43528E+04
'pendf tape for photon interaction cross sections endl97'/ 1.48393E+04
100 1 0 1.50000E+04
.01/ 1.50150E+04
'1-h'/ 1.52000E+04
600 1 0 1.58600E+04
.01/ 1.69000E+04
'6-c'/ 1.79300E+04
1400 1 0 1.89700E+04
.01/ 2.00000E+04
'14-Si'/ 2.00200E+04
1500 1 0 2.12500E+04
.01/ 2.25000E+04
'15-P'/ 2.37500E+04
1600 1 0 2.55140E+04
.01/ 2.62500E+04
'16-S'/ 2.70000E+04
2300 1 0 2.72500E+04
.01/ 2.76000E+04
'23-V'/ 2.80000E+04
2400 1 0 2.82000E+04
.01/ 2.85000E+04
'24-Cr'/ 2.87000E+04
2500 1 0 2.90000E+04
.01/ 2.92500E+04
'25-Mn'/ 2.95000E+04
2600 1 0 2.97500E+04
.01/ 3.00000E+04
'26-Fe'/ 3.00300E+04
2700 1 0 3.05000E+04
.01/ 3.10000E+04
'27-Co'/ 3.15000E+04
2800 1 0 3.20000E+04
.01/ 3.25000E+04
'28-Ni'/ 3.31694E+04
2900 1 0 3.35000E+04
.01/ 3.40000E+04
'29-Cu'/ 3.45000E+04
4200 1 0 3.47500E+04
.01/ 3.50000E+04
'42-Mo'/ 3.55500E+04
0/ 3.59846E+04
gaminr 3.62500E+04
30 31 0 33 3.65000E+04
100 1 3 8/ 3.67500E+04
'244 group photon library / p7'/ 3.70000E+04
244 3.72500E+04
1.00000E+03 3.75000E+04
1.71293E+03 3.77500E+04
2.55619E+03 3.80000E+04
3.58825E+03 3.82500E+04
4.91881E+03 3.85000E+04
6.79412E+03 3.87500E+04
1.00000E+04 3.90000E+04
1.00100E+04 3.92500E+04
1.03671E+04 3.95000E+04
1.07600E+04 3.97500E+04
1.12154E+04 4.00000E+04
1.15637E+04 4.00400E+04
1.19100E+04 4.05000E+04
1.20998E+04 4.10000E+04
1.22839E+04 4.12500E+04
1.28241E+04 4.15000E+04
1.30400E+04 4.17500E+04
1.34185E+04 4.20000E+04
4.22500E+04

```

4.25000E+04
4.27500E+04
4.30000E+04
NJOY sample continued:

4.32500E+04
4.35000E+04
4.37000E+04
4.40000E+04
4.42500E+04
4.50000E+04
4.60000E+04
4.75000E+04
4.85000E+04
5.00000E+04
5.00500E+04
5.10000E+04
5.25000E+04
5.35000E+04
5.50000E+04
5.75000E+04
6.00000E+04
6.00600E+04
6.50000E+04
6.95250E+04
7.61110E+04
7.75000E+04
8.00000E+04
8.00800E+04
8.07249E+04
8.31023E+04
8.60000E+04
8.80000E+04
9.00000E+04
9.10000E+04
9.20000E+04
9.30000E+04
9.40000E+04
9.50000E+04
9.60000E+04
9.70000E+04
9.80000E+04
9.90000E+04
1.00000E+05
1.00100E+05
1.25000E+05
1.30000E+05
1.35000E+05
1.37500E+05
1.40000E+05
1.45000E+05
1.50000E+05
1.50150E+05
1.56000E+05
1.57000E+05
1.62500E+05
1.65000E+05
1.70000E+05
1.72500E+05
1.75000E+05
1.80000E+05
1.85000E+05
1.90000E+05
1.95000E+05
2.00000E+05
2.00200E+05
3.80000E+06
3.90000E+06

2.25000E+05
2.50000E+05
2.60000E+05
2.75000E+05
2.85000E+05
3.00000E+05
3.00300E+05
3.12500E+05
3.25000E+05
3.37500E+05
3.50000E+05
3.60000E+05
3.70000E+05
3.85000E+05
4.00000E+05
4.00400E+05
4.50000E+05
5.00000E+05
5.00500E+05
5.50000E+05
5.75000E+05
5.95000E+05
5.97500E+05
6.00000E+05
6.00600E+05
6.20000E+05
6.35000E+05
6.65000E+05
6.80000E+05
6.90000E+05
7.00000E+05
7.20000E+05
7.35000E+05
7.50000E+05
7.80000E+05
8.00000E+05
8.00800E+05
8.25000E+05
8.50000E+05
9.00000E+05
9.50000E+05
1.00000E+06
1.00100E+06
1.10000E+06
1.33000E+06
1.33500E+06
1.40000E+06
1.50000E+06
1.50100E+06
1.60000E+06
1.66000E+06
1.75000E+06
1.87500E+06
2.00000E+06
2.00100E+06
2.16600E+06
2.33300E+06
2.50000E+06
2.66600E+06
2.83300E+06
3.00000E+06
3.00100E+06
3.16600E+06
3.33300E+06
3.50000E+06
3.65000E+06

4.0000E+06
4.0010E+06
4.2000E+06
4.4000E+06
4.5000E+06
4.7000E+06
5.0000E+06
5.0010E+06
5.2000E+06
5.4000E+06
5.5000E+06
5.7500E+06
6.0000E+06
6.0010E+06
6.2500E+06
6.5000E+06
6.7500E+06
7.0000E+06
7.2500E+06
7.5000E+06
7.7500E+06
8.0000E+06
8.0010E+06
8.5000E+06
9.0000E+06
9.5000E+06
1.0000E+07
1.0001E+07
600
-1 0/
600
-1 0/
1400
-1 0/
1500
-1 0/
1600
-1 0/
2300
-1 0/
2400
-1 0/
2500
-1 0/
2600
-1 0/
2700
-1 0/
2800
-1 0/
2900
-1 0/
4200
-1 0/
0/
stop

Appendix 11: Sample CEPXS Input File

```
title 8.0000E-01
10 MeV normal photons on Poly SS 7.8000E-01
cutoff .001 7.5000E-01
energy 10.0005 7.3500E-01
legendre 7 7.2000E-01
electrons 7.0000E-01
user 244 6.9000E-01
1.0000E+01 6.8000E-01
9.5000E+00 6.6500E-01
9.0000E+00 6.3500E-01
8.5000E+00 6.2000E-01
8.0010E+00 6.0060E-01
8.0000E+00 6.0000E-01
7.7500E+00 5.9750E-01
7.5000E+00 5.9500E-01
7.2500E+00 5.7500E-01
7.0000E+00 5.5000E-01
6.7500E+00 5.0050E-01
6.5000E+00 5.0000E-01
6.2500E+00 4.5000E-01
6.0010E+00 4.0040E-01
6.0000E+00 4.0000E-01
5.7500E+00 3.8500E-01
5.5000E+00 3.7000E-01
5.4000E+00 3.6000E-01
5.2000E+00 3.5000E-01
5.0010E+00 3.3750E-01
5.0000E+00 3.2500E-01
4.7000E+00 3.1250E-01
4.5000E+00 3.0030E-01
4.4000E+00 3.0000E-01
4.2000E+00 2.8500E-01
4.0010E+00 2.7500E-01
4.0000E+00 2.6000E-01
3.9000E+00 2.5000E-01
3.8000E+00 2.2500E-01
3.6500E+00 2.0020E-01
3.5000E+00 2.0000E-01
3.3330E+00 1.9500E-01
3.1660E+00 1.9000E-01
3.0010E+00 1.8500E-01
3.0000E+00 1.8000E-01
2.8330E+00 1.7500E-01
2.6660E+00 1.7250E-01
2.5000E+00 1.7000E-01
2.3330E+00 1.6500E-01
2.1660E+00 1.6250E-01
2.0010E+00 1.5700E-01
2.0000E+00 1.5600E-01
1.8750E+00 1.5015E-01
1.7500E+00 1.5000E-01
1.6600E+00 1.4500E-01
1.6000E+00 1.4000E-01
1.5010E+00 1.3750E-01
1.5000E+00 1.3500E-01
1.4000E+00 1.3000E-01
1.3350E+00 1.2500E-01
1.3300E+00 1.0010E-01
1.1000E+00 1.0000E-01
1.0010E+00 9.9000E-02
1.0000E+00 9.8000E-02
9.5000E-01 9.7000E-02
9.0000E-01 9.6000E-02
8.5000E-01 9.5000E-02
8.2500E-01 9.4000E-02
8.0080E-01 9.3000E-02
```

CEPXS Sample Input File (Continued)

9.20000E-02	3.15000E-02
9.10000E-02	3.10000E-02
9.00000E-02	3.05000E-02
8.80000E-02	3.00300E-02
8.60000E-02	3.00000E-02
8.31023E-02	2.97500E-02
8.07249E-02	2.95000E-02
8.00800E-02	2.92500E-02
8.00000E-02	2.90000E-02
7.75000E-02	2.87000E-02
7.61110E-02	2.85000E-02
6.95250E-02	2.82000E-02
6.50000E-02	2.80000E-02
6.00600E-02	2.76000E-02
6.00000E-02	2.72500E-02
5.75000E-02	2.70000E-02
5.50000E-02	2.62500E-02
5.35000E-02	2.55140E-02
5.25000E-02	2.37500E-02
5.10000E-02	2.25000E-02
5.00500E-02	2.12500E-02
5.00000E-02	2.00200E-02
4.85000E-02	2.00000E-02
4.75000E-02	1.89700E-02
4.60000E-02	1.79300E-02
4.50000E-02	1.69000E-02
4.42500E-02	1.58600E-02
4.40000E-02	1.52000E-02
4.37000E-02	1.50150E-02
4.35000E-02	1.50000E-02
4.32500E-02	1.48393E-02
4.30000E-02	1.43528E-02
4.27500E-02	1.38799E-02
4.25000E-02	1.34185E-02
4.22500E-02	1.30400E-02
4.20000E-02	1.28241E-02
4.17500E-02	1.22839E-02
4.15000E-02	1.20998E-02
4.12500E-02	1.19100E-02
4.10000E-02	1.15637E-02
4.05000E-02	1.12154E-02
4.00400E-02	1.07600E-02
4.00000E-02	1.03671E-02
3.97500E-02	1.00100E-02
3.95000E-02	1.00000E-02
3.92500E-02	6.79412E-03
3.90000E-02	4.91881E-03
3.87500E-02	3.58825E-03
3.85000E-02	2.55619E-03
3.82500E-02	1.71293E-03
3.80000E-02	1.00000E-03
3.77500E-02	photons
3.75000E-02	user 244
3.72500E-02	1.00000E+01
3.70000E-02	9.50000E+00
3.67500E-02	9.00000E+00
3.65000E-02	8.50000E+00
3.62500E-02	8.00100E+00
3.59846E-02	8.00000E+00
3.55500E-02	7.75000E+00
3.50000E-02	7.50000E+00
3.47500E-02	7.25000E+00
3.45000E-02	7.00000E+00
3.40000E-02	6.75000E+00
3.35000E-02	6.50000E+00
3.31694E-02	6.25000E+00
3.25000E-02	6.00100E+00
3.20000E-02	6.00000E+00
	5.75000E+00
	5.50000E+00

CEPXS Sample Input File (Continued)

5.40000E+00	3.37500E-01
5.20000E+00	3.25000E-01
5.00100E+00	3.12500E-01
5.00000E+00	3.00300E-01
4.70000E+00	3.00000E-01
4.50000E+00	2.85000E-01
4.40000E+00	2.75000E-01
4.20000E+00	2.60000E-01
4.00100E+00	2.50000E-01
4.00000E+00	2.25000E-01
3.90000E+00	2.00200E-01
3.80000E+00	2.00000E-01
3.65000E+00	1.95000E-01
3.50000E+00	1.90000E-01
3.33300E+00	1.85000E-01
3.16600E+00	1.80000E-01
3.00100E+00	1.75000E-01
3.00000E+00	1.72500E-01
2.83300E+00	1.70000E-01
2.66600E+00	1.65000E-01
2.50000E+00	1.62500E-01
2.33300E+00	1.57000E-01
2.16600E+00	1.56000E-01
2.00100E+00	1.50150E-01
2.00000E+00	1.50000E-01
1.87500E+00	1.45000E-01
1.75000E+00	1.40000E-01
1.66000E+00	1.37500E-01
1.60000E+00	1.35000E-01
1.50100E+00	1.30000E-01
1.50000E+00	1.25000E-01
1.40000E+00	1.00100E-01
1.33500E+00	1.00000E-01
1.33000E+00	9.90000E-02
1.10000E+00	9.80000E-02
1.00100E+00	9.70000E-02
1.00000E+00	9.60000E-02
9.50000E-01	9.50000E-02
9.00000E-01	9.40000E-02
8.50000E-01	9.30000E-02
8.25000E-01	9.20000E-02
8.00800E-01	9.10000E-02
8.00000E-01	9.00000E-02
7.80000E-01	8.80000E-02
7.50000E-01	8.60000E-02
7.35000E-01	8.31023E-02
7.20000E-01	8.07249E-02
7.00000E-01	8.00800E-02
6.90000E-01	8.00000E-02
6.80000E-01	7.75000E-02
6.65000E-01	7.61110E-02
6.35000E-01	6.95250E-02
6.20000E-01	6.50000E-02
6.00600E-01	6.00600E-02
6.00000E-01	6.00000E-02
5.97500E-01	5.75000E-02
5.95000E-01	5.50000E-02
5.75000E-01	5.35000E-02
5.50000E-01	5.25000E-02
5.00500E-01	5.10000E-02
5.00000E-01	5.00500E-02
4.50000E-01	5.00000E-02
4.00400E-01	4.85000E-02
4.00000E-01	4.75000E-02
3.85000E-01	4.60000E-02
3.70000E-01	4.50000E-02
3.60000E-01	4.42500E-02
3.50000E-01	4.40000E-02
	4.37000E-02
	4.35000E-02

CEPXS Sample Input File (Continued)

4.32500E-02	2.76000E-02
4.30000E-02	2.72500E-02
4.27500E-02	2.70000E-02
4.25000E-02	2.62500E-02
4.22500E-02	2.55140E-02
4.20000E-02	2.37500E-02
4.17500E-02	2.25000E-02
4.15000E-02	2.12500E-02
4.12500E-02	2.00200E-02
4.10000E-02	2.00000E-02
4.05000E-02	1.89700E-02
4.00400E-02	1.79300E-02
4.00000E-02	1.69000E-02
3.97500E-02	1.58600E-02
3.95000E-02	1.52000E-02
3.92500E-02	1.50150E-02
3.90000E-02	1.50000E-02
3.87500E-02	1.48393E-02
3.85000E-02	1.43528E-02
3.82500E-02	1.38799E-02
3.80000E-02	1.34185E-02
3.77500E-02	1.30400E-02
3.75000E-02	1.28241E-02
3.72500E-02	1.22839E-02
3.70000E-02	1.20998E-02
3.67500E-02	1.19100E-02
3.65000E-02	1.15637E-02
3.62500E-02	1.12154E-02
3.59846E-02	1.07600E-02
3.55500E-02	1.03671E-02
3.50000E-02	1.00100E-02
3.47500E-02	1.00000E-02
3.45000E-02	6.79412E-03
3.40000E-02	4.91881E-03
3.35000E-02	3.58825E-03
3.31694E-02	2.55619E-03
3.25000E-02	1.71293E-03
3.20000E-02	1.00000E-03
3.15000E-02	photon-source
3.10000E-02	full-coupling
3.05000E-02	material h .143716 c .856284
3.00300E-02	density .93
3.00000E-02	material c .000136 si .0108 p .00007 s .000078 v .00041 cr
2.97500E-02	.1846 -
2.95000E-02	mn .00085 fe .701826 co .0009 ni .1 cu .00029 mo .00004
2.92500E-02	density 8.03
2.90000E-02	print
2.87000E-02	rows
2.85000E-02	direction
2.82000E-02	normal
2.80000E-02	geometry 2
2 30 2.91136 50	1 30 2.91136 50
	2 30 2.91136 50

Appendix 12: PARTISN Sample input file

```

6 0 0
E = 100 keV
mat = SS Pb
mu = 1
mfp = 9/100
Sn = s100
P = p7
/***** BLOCK 1 *****/
igeom=1 ngroup=488 isn= 50 niso= 2 mt= 2 nzone=2
im=2 it= 900 idimen=1 maxlcm=4000000 maxscm= 5000000
iquad= 3 nn=1
t
/***** BLOCK 2 *****/
xmesh=0.0; 2.38879 2.42077
xints= 700 200
zones=1 2
t
/***** BLOCK 3 *****/
lib= bxslib maxord= 7 ihm=981 iht= 6 ihs= 494 ifido=0 ititl=1
i2lp1=0
edname=char secp ener
ebound=
10.00100 10.00000 9.50000 9.00000 8.50000 8.00100 8.00000
7.75000 7.50000 7.25000 7.00000 6.75000 6.50000 6.25000
6.00100 6.00000 5.75000 5.50000 5.40000 5.20000 5.00100
5.00000 4.70000 4.50000 4.40000 4.20000 4.00100 4.00000
3.90000 3.80000 3.65000 3.50000 3.33300 3.16600 3.00100
3.00000 2.83300 2.66600 2.50000 2.33300 2.16600 2.00100
2.00000 1.87500 1.75000 1.66000 1.60000 1.50100 1.50000
1.40000 1.33500 1.33000 1.10000 1.00100 1.00000 0.95000
0.90000 0.85000 0.82500 0.80080 0.80000 0.78000 0.75000
0.73500 0.72000 0.70000 0.69000 0.68000 0.66500 0.63500
0.62000 0.60060 0.60000 0.59750 0.59500 0.57500 0.55000
0.50050 0.50000 0.45000 0.40040 0.40000 0.38500 0.37000
0.36000 0.35000 0.33750 0.32500 0.31250 0.30030 0.30000
0.28500 0.27500 0.26000 0.25000 0.22500 0.20020 0.20000
0.19500 0.19000 0.18500 0.18000 0.17500 0.17250 0.17000
0.16500 0.16250 0.15700 0.15600 0.15015 0.15000 0.14500
0.14000 0.13750 0.13500 0.13000 0.12500 0.10010 0.10000
0.09900 0.09800 0.09700 0.09600 0.09500 0.09400 0.09300
0.09200 0.09100 0.09000 0.08800 0.08600 0.08310 0.08072
0.08008 0.08000 0.07750 0.07611 0.06953 0.06500 0.06006
0.06000 0.05750 0.05500 0.05350 0.05250 0.05100 0.05005
0.05000 0.04850 0.04750 0.04600 0.04500 0.04425 0.04400
0.04370 0.04350 0.04325 0.04300 0.04275 0.04250 0.04225
0.04200 0.04175 0.04150 0.04125 0.04100 0.04050 0.04004
0.04000 0.03975 0.03950 0.03925 0.03900 0.03875 0.03850
0.03825 0.03800 0.03775 0.03750 0.03725 0.03700 0.03675
0.03650 0.03625 0.03598 0.03555 0.03500 0.03475 0.03450
0.03400 0.03350 0.03317 0.03250 0.03200 0.03150 0.03100
0.03050 0.03003 0.03000 0.02975 0.02950 0.02925 0.02900
0.02870 0.02850 0.02820 0.02800 0.02760 0.02725 0.02700
0.02625 0.02551 0.02375 0.02250 0.02125 0.02002 0.02000
0.01897 0.01793 0.01690 0.01586 0.01520 0.01502 0.01500
0.01484 0.01435 0.01388 0.01342 0.01304 0.01282 0.01228
0.01210 0.01191 0.01156 0.01122 0.01076 0.01037 0.01001
0.01000 0.00679 0.00492 0.00359 0.00256 0.00171 0.00100
10.00000 9.50000 9.00000 8.50000 8.00100 8.00000 7.75000
7.50000 7.25000 7.00000 6.75000 6.50000 6.25000 6.00100
6.00000 5.75000 5.50000 5.40000 5.20000 5.00100 5.00000
4.70000 4.50000 4.40000 4.20000 4.00100 4.00000 3.90000
3.80000 3.65000 3.50000 3.33300 3.16600 3.00100 3.00000
2.83300 2.66600 2.50000 2.33300 2.16600 2.00100 2.00000
1.87500 1.75000 1.66000 1.60000 1.50100 1.50000 1.40000
1.33500 1.33000 1.10000 1.00100 1.00000 0.95000 0.90000
0.85000 0.82500 0.80080 0.80000 0.78000 0.75000
0.73500
0.72000 0.70000 0.69000 0.68000 0.66500 0.63500
0.62000
0.60060 0.60000 0.59750 0.59500 0.57500 0.55000 0.50050
0.50000 0.45000 0.40040 0.40000 0.38500 0.37000 0.36000
0.35000 0.33750 0.32500 0.31250 0.30030 0.30000 0.28500
0.27500 0.26000 0.25000 0.22500 0.20020 0.20000 0.19500
0.19000 0.18500 0.18000 0.17500 0.17250 0.17000 0.16500
0.16250 0.15700 0.15600 0.15015 0.15000 0.14500 0.14000
0.13750 0.13500 0.13000 0.12500 0.10010 0.10000 0.09900
0.09800 0.09700 0.09600 0.09500 0.09400 0.09300 0.09200
0.09100 0.09000 0.08800 0.08600 0.08310 0.08072 0.08008
0.08000 0.07750 0.07611 0.06953 0.06500 0.06006 0.06000
0.05750 0.05500 0.05350 0.05250 0.05100 0.05005 0.05000
0.04850 0.04750 0.04600 0.04500 0.04425 0.04400 0.04370
0.04350 0.04325 0.04300 0.04275 0.04250 0.04225 0.04200
0.04175 0.04150 0.04125 0.04100 0.04050 0.04004 0.04000
0.03975 0.03950 0.03925 0.03900 0.03875 0.03850 0.03825
0.03800 0.03775 0.03750 0.03725 0.03700 0.03675 0.03650
0.03625 0.03598 0.03555 0.03500 0.03475 0.03450 0.03400
0.03350 0.03317 0.03250 0.03200 0.03150 0.03100 0.03050
0.03003 0.03000 0.02975 0.02950 0.02925 0.02900 0.02870
0.02850 0.02820 0.02800 0.02760 0.02725 0.02700 0.02625
0.02551 0.02375 0.02250 0.02125 0.02002 0.02000 0.01897
0.01793 0.01690 0.01586 0.01520 0.01502 0.01500 0.01484
0.01435 0.01388 0.01342 0.01304 0.01282 0.01228 0.01210
0.01191 0.01156 0.01122 0.01076 0.01037 0.01001 0.01000
0.00679 0.00492 0.00359 0.00256 0.00171 0.00100
t
/***** BLOCK 4 *****/
matls=isos assign=
1 1 1.0; 2 2 1.0;
t
/***** BLOCK 5 *****/
mu=1.00000000000 0.99925857797 0.99751524904
0.99477730719 0.99104769371 0.98633016382
0.98062943072 0.97395118101 0.96630207344
0.95768973368 0.94812274716 0.93761065074
0.92616392325 0.91379397517 0.90051313718
0.88633464797 0.87127264099 0.85534213042
0.83855899613 0.82093996795 0.80250260891
0.78326529779 0.76324721074 0.74246830226
0.72094928520 0.69871161020 0.67577744426
0.65216964865 0.62791175614 0.60302794752
0.57754302752 0.55148240007 0.52487204296
0.49773848198 0.47010876445 0.44201043227
0.41347149448 0.38452039931 0.35518600584
0.32549755523 0.29548464157 0.26517718240
0.23460538884 0.20379973553 0.17279093021
0.14160988313 0.11028767624 0.07885553219
0.04734478323 0.01578683997;
wgt=0.00010101010 0.00062253833 0.00112053988
0.00161716296 0.00211213817 0.00260499904
0.00309526016 0.00358243461 0.00406603742
0.00454558681 0.00502060489 0.00549061821
0.00595515830 0.00641376212 0.00686597253
0.00731133877 0.00774941690 0.00817977022
0.00860196977 0.00901559468 0.00942023264
0.00981548031 0.01020094369 0.01057623855
0.01094099078 0.01129483679 0.01163742386
0.01196841049 0.01228746675 0.01259427460
0.01288852819 0.01316993423 0.01343821218
0.01369309463 0.01393432751 0.01416167035
0.01437489652 0.01457379349 0.01475816298
0.01492782121 0.01508259907 0.01522234226
0.01534691149 0.01545618259 0.01555004662
0.01562841004 0.01569119471 0.01573833806

```

PARTISN Sample input file (continued)

```
0.01576979309 0.01578552845;
/
ievt= 0 isct= 7 ith=0 ibl=0 ibr=0 epsi=1.e-4 iitl=100 nll=50
saleft=
50r0; 116y1;
1,49r0;
50r0; 369y1;
norm=1 sourcp=3 xsectp=1
t
/***** BLOCK 6 *****/
pted=1 icoll= 244,244 igrped= 3
rsfnam= flux, airExp, Dose_e, Dose_c
/ normalized flux
rsfe=488r1.0;
/ air exposure
1.4501E-01 1.4218E-01 1.3650E-01 1.3075E-01
1.2494E-01 1.2201E-01 1.2060E-01 1.1778E-01
1.1494E-01 1.1207E-01 1.0918E-01 1.0626E-01
1.0330E-01 1.0033E-01 9.8826E-02 9.7372E-02
9.4458E-02 9.2399E-02 9.0612E-02 8.8215E-02
8.7006E-02 8.5215E-02 8.2220E-02 8.0398E-02
7.8549E-02 7.6063E-02 7.4806E-02 7.4172E-02
7.2911E-02 7.1318E-02 6.9384E-02 6.7310E-02
6.5092E-02 6.2848E-02 6.1762E-02 6.0582E-02
5.8168E-02 5.5759E-02 5.3299E-02 5.0777E-02
4.8208E-02 4.6908E-02 4.5846E-02 4.3717E-02
4.1855E-02 4.0535E-02 3.9113E-02 3.8214E-02
3.7242E-02 3.5644E-02 3.4960E-02 3.2502E-02
2.9003E-02 2.7901E-02 2.7293E-02 2.6094E-02
2.4886E-02 2.3974E-02 2.3372E-02 2.3066E-02
2.2792E-02 2.2131E-02 2.1534E-02 2.1136E-02
2.0670E-02 2.0270E-02 2.0003E-02 1.9668E-02
1.9065E-02 1.8460E-02 1.7996E-02 1.7726E-02
1.7682E-02 1.7610E-02 1.7286E-02 1.6636E-02
1.5560E-02 1.4837E-02 1.4070E-02 1.2559E-02
1.1802E-02 1.1555E-02 1.1074E-02 1.0674E-02
1.0355E-02 9.9970E-03 9.6008E-03 9.2059E-03
8.8171E-03 8.6207E-03 8.3634E-03 7.9437E-03
7.5280E-03 7.1150E-03 6.5450E-03 5.7448E-03
5.3471E-03 5.2616E-03 5.0974E-03 4.9341E-03
4.7719E-03 4.6107E-03 4.4905E-03 4.4107E-03
4.2917E-03 4.1730E-03 4.0475E-03 3.9457E-03
3.8394E-03 3.7463E-03 3.6709E-03 3.5251E-03
3.4163E-03 3.3441E-03 3.2363E-03 3.0933E-03
2.6749E-03 2.3264E-03 2.3152E-03 2.2955E-03
2.2758E-03 2.2561E-03 2.2363E-03 2.2165E-03
2.1967E-03 2.1768E-03 2.1569E-03 2.1370E-03
2.1070E-03 2.0670E-03 2.0177E-03 1.9644E-03
1.9338E-03 1.9264E-03 1.9199E-03 1.9109E-03
1.8917E-03 1.8639E-03 1.8385E-03 1.8248E-03
1.8496E-03 1.9016E-03 1.9456E-03 1.9745E-03
2.0049E-03 2.0355E-03 2.0483E-03 2.0901E-03
2.1602E-03 2.2356E-03 2.3148E-03 2.3733E-03
2.4079E-03 2.4274E-03 2.4454E-03 2.4618E-03
2.4802E-03 2.4989E-03 2.5179E-03 2.5371E-03
2.5565E-03 2.5763E-03 2.5963E-03 2.6165E-03
2.6371E-03 2.6686E-03 2.7097E-03 2.7314E-03
2.7489E-03 2.7805E-03 2.8127E-03 2.8454E-03
2.8788E-03 2.9127E-03 2.9473E-03 2.9825E-03
3.0184E-03 3.0550E-03 3.0922E-03 3.1302E-03
3.1689E-03 3.2083E-03 3.2485E-03 3.2908E-03
3.3498E-03 3.4354E-03 3.5070E-03 3.5531E-03
3.6246E-03 3.7228E-03 3.8072E-03 3.9141E-03
4.0436E-03 4.1601E-03 4.2819E-03 4.4093E-03
4.5386E-03 4.6068E-03 4.6518E-03 4.7343E-03
4.8191E-03 4.9061E-03 5.0047E-03 5.0965E-03
5.1914E-03 5.2883E-03 5.4092E-03 5.5650E-03
5.6943E-03 5.9240E-03 6.2857E-03 6.9967E-03
7.9714E-03 8.9576E-03 1.0124E-02 1.0767E-02
1.1427E-02 1.2854E-02 1.4558E-02 1.6616E-02
1.8599E-02 1.9708E-02 1.9989E-02 2.0242E-02
2.1226E-02 2.2791E-02 2.4483E-02 2.6160E-02
2.7443E-02 2.9270E-02 3.1109E-02 3.2150E-02
3.3750E-02 3.5980E-02 3.8863E-02 4.2247E-02
4.5619E-02 4.7370E-02 7.6507E-02 1.5430E-01
2.8957E-01 5.1701E-01 1.0277E+00 2.4983E+00
```

```
4.8191E-03 4.9061E-03 5.0047E-03 5.0965E-03
5.1914E-03 5.2883E-03 5.4092E-03 5.5650E-03
5.6943E-03 5.9240E-03 6.2857E-03 6.9967E-03
7.9714E-03 8.9576E-03 1.0124E-02 1.0767E-02
1.1427E-02 1.2854E-02 1.4558E-02 1.6616E-02
1.8599E-02 1.9708E-02 1.9989E-02 2.0242E-02
2.1226E-02 2.2791E-02 2.4483E-02 2.6160E-02
2.7443E-02 2.9270E-02 3.1109E-02 3.2150E-02
3.3750E-02 3.5980E-02 3.8863E-02 4.2247E-02
4.5619E-02 4.7370E-02 7.6507E-02 1.5430E-01
2.8957E-01 5.1701E-01 1.0277E+00 2.4983E+00
/ repeat 244 groups for electrons/positrons
1.4501E-01 1.4218E-01 1.3650E-01 1.3075E-01
1.2494E-01 1.2201E-01 1.2060E-01 1.1778E-01
1.1494E-01 1.1207E-01 1.0918E-01 1.0626E-01
1.0330E-01 1.0033E-01 9.8826E-02 9.7372E-02
9.4458E-02 9.2399E-02 9.0612E-02 8.8215E-02
8.7006E-02 8.5215E-02 8.2220E-02 8.0398E-02
7.8549E-02 7.6063E-02 7.4806E-02 7.4172E-02
7.2911E-02 7.1318E-02 6.9384E-02 6.7310E-02
6.5092E-02 6.2848E-02 6.1762E-02 6.0582E-02
5.8168E-02 5.5759E-02 5.3299E-02 5.0777E-02
4.8208E-02 4.6908E-02 4.5846E-02 4.3717E-02
4.1855E-02 4.0535E-02 3.9113E-02 3.8214E-02
3.7242E-02 3.5644E-02 3.4960E-02 3.2502E-02
2.9003E-02 2.7901E-02 2.7293E-02 2.6094E-02
2.4886E-02 2.3974E-02 2.3372E-02 2.3066E-02
2.2792E-02 2.2131E-02 2.1534E-02 2.1136E-02
2.0670E-02 2.0270E-02 2.0003E-02 1.9668E-02
1.9065E-02 1.8460E-02 1.7996E-02 1.7726E-02
1.7682E-02 1.7610E-02 1.7286E-02 1.6636E-02
1.5560E-02 1.4837E-02 1.4070E-02 1.2559E-02
1.1802E-02 1.1555E-02 1.1074E-02 1.0674E-02
1.0355E-02 9.9970E-03 9.6008E-03 9.2059E-03
8.8171E-03 8.6207E-03 8.3634E-03 7.9437E-03
7.5280E-03 7.1150E-03 6.5450E-03 5.7448E-03
5.3471E-03 5.2616E-03 5.0974E-03 4.9341E-03
4.7719E-03 4.6107E-03 4.4905E-03 4.4107E-03
4.2917E-03 4.1730E-03 4.0475E-03 3.9457E-03
3.8394E-03 3.7463E-03 3.6709E-03 3.5251E-03
3.4163E-03 3.3441E-03 3.2363E-03 3.0933E-03
2.6749E-03 2.3264E-03 2.3152E-03 2.2955E-03
2.2758E-03 2.2561E-03 2.2363E-03 2.2165E-03
2.1967E-03 2.1768E-03 2.1569E-03 2.1370E-03
2.1070E-03 2.0670E-03 2.0177E-03 1.9644E-03
1.9338E-03 1.9264E-03 1.9199E-03 1.9109E-03
1.8917E-03 1.8639E-03 1.8385E-03 1.8248E-03
1.8496E-03 1.9016E-03 1.9456E-03 1.9745E-03
2.0049E-03 2.0355E-03 2.0483E-03 2.0901E-03
2.1602E-03 2.2356E-03 2.3148E-03 2.3733E-03
2.4079E-03 2.4274E-03 2.4454E-03 2.4618E-03
2.4802E-03 2.4989E-03 2.5179E-03 2.5371E-03
2.5565E-03 2.5763E-03 2.5963E-03 2.6165E-03
2.6371E-03 2.6686E-03 2.7097E-03 2.7314E-03
2.7489E-03 2.7805E-03 2.8127E-03 2.8454E-03
2.8788E-03 2.9127E-03 2.9473E-03 2.9825E-03
3.0184E-03 3.0550E-03 3.0922E-03 3.1302E-03
3.1689E-03 3.2083E-03 3.2485E-03 3.2908E-03
3.3498E-03 3.4354E-03 3.5070E-03 3.5531E-03
3.6246E-03 3.7228E-03 3.8072E-03 3.9141E-03
4.0436E-03 4.1601E-03 4.2819E-03 4.4093E-03
4.5386E-03 4.6068E-03 4.6518E-03 4.7343E-03
4.8191E-03 4.9061E-03 5.0047E-03 5.0965E-03
5.1914E-03 5.2883E-03 5.4092E-03 5.5650E-03
5.6943E-03 5.9240E-03 6.2857E-03 6.9967E-03
7.9714E-03 8.9576E-03 1.0124E-02 1.0767E-02
1.1427E-02 1.2854E-02 1.4558E-02 1.6616E-02
1.8599E-02 1.9708E-02 1.9989E-02 2.0242E-02
```

PARTISN Sample input file (continued)

2.1226E-02 2.2791E-02 2.4483E-02 2.6160E-02
2.7443E-02 2.9270E-02 3.1109E-02 3.2150E-02
3.3750E-02 3.5980E-02 3.8863E-02 4.2247E-02
4.5619E-02 4.7370E-02 7.6507E-02 1.5430E-01
2.8957E-01 5.1701E-01 1.0277E+00 2.4983E+00;
/H*(10) flux response [extrapolated]
2.5601E+01 2.5110E+01 2.4123E+01 2.3123E+01
2.2111E+01 2.1601E+01 2.1359E+01 2.0874E+01
2.0384E+01 1.9890E+01 1.9390E+01 1.8886E+01
1.8375E+01 1.7861E+01 1.7601E+01 1.7343E+01
1.6825E+01 1.6459E+01 1.6142E+01 1.5716E+01
1.5501E+01 1.5193E+01 1.4679E+01 1.4365E+01
1.4047E+01 1.3618E+01 1.3401E+01 1.3290E+01
1.3069E+01 1.2789E+01 1.2449E+01 1.2085E+01
1.1695E+01 1.1300E+01 1.1101E+01 1.0904E+01
1.0506E+01 1.0101E+01 9.6860E+00 9.2589E+00
8.8226E+00 8.6014E+00 8.3927E+00 7.9748E+00
7.6105E+00 7.3531E+00 7.0765E+00 6.9018E+00
6.7379E+00 6.4685E+00 6.3529E+00 5.9511E+00
5.3806E+00 5.2018E+00 5.0994E+00 4.8971E+00
4.6922E+00 4.5370E+00 4.4341E+00 4.3817E+00
4.3339E+00 4.2184E+00 4.1140E+00 4.0441E+00
3.9623E+00 3.8919E+00 3.8448E+00 3.7858E+00
3.6790E+00 3.5719E+00 3.4895E+00 3.4414E+00
3.4337E+00 3.4211E+00 3.3641E+00 3.2500E+00
3.0595E+00 2.9313E+00 2.7930E+00 2.5191E+00
2.3811E+00 2.3366E+00 2.2499E+00 2.1775E+00
2.1196E+00 2.0543E+00 1.9818E+00 1.9091E+00
1.8373E+00 1.8009E+00 1.7550E+00 1.6800E+00
1.6050E+00 1.5300E+00 1.4250E+00 1.2756E+00
1.2006E+00 1.1844E+00 1.1533E+00 1.1222E+00
1.0911E+00 1.0601E+00 1.0368E+00 1.0213E+00
9.9811E-01 9.7490E-01 9.5018E-01 9.3010E-01
9.0897E-01 8.9046E-01 8.7616E-01 8.4846E-01
8.2764E-01 8.1374E-01 7.9285E-01 7.6494E-01
6.8077E-01 6.1028E-01 6.0807E-01 6.0422E-01
6.0035E-01 5.9646E-01 5.9256E-01 5.8864E-01
5.8471E-01 5.8076E-01 5.7680E-01 5.7282E-01
5.6681E-01 5.5875E-01 5.4878E-01 5.3794E-01
5.3168E-01 5.3017E-01 5.2888E-01 5.2712E-01
5.2331E-01 5.1782E-01 5.1278E-01 5.1003E-01
5.1453E-01 5.2389E-01 5.3176E-01 5.3690E-01
5.4225E-01 5.4764E-01 5.4989E-01 5.5575E-01
5.6550E-01 5.7577E-01 5.8642E-01 5.9419E-01
5.9873E-01 6.0128E-01 6.0362E-01 6.0574E-01
6.0813E-01 6.1053E-01 6.1296E-01 6.1542E-01
6.1790E-01 6.2040E-01 6.2293E-01 6.2548E-01
6.2806E-01 6.3199E-01 6.3709E-01 6.3978E-01
6.4165E-01 6.4496E-01 6.4831E-01 6.5170E-01
6.5513E-01 6.5860E-01 6.6211E-01 6.6567E-01
6.6926E-01 6.7290E-01 6.7658E-01 6.8031E-01
6.8409E-01 6.8791E-01 6.9178E-01 6.9582E-01
7.0140E-01 7.0942E-01 7.1605E-01 7.2028E-01
7.2675E-01 7.3556E-01 7.4304E-01 7.5233E-01
7.6346E-01 7.7329E-01 7.8341E-01 7.9383E-01
8.0422E-01 8.0967E-01 8.1217E-01 8.1656E-01
8.2100E-01 8.2550E-01 8.3053E-01 8.3516E-01
8.3988E-01 8.4465E-01 8.5049E-01 8.5791E-01
8.6396E-01 8.7439E-01 8.9037E-01 9.1956E-01
9.5720E-01 9.9190E-01 1.0297E+00 1.0497E+00
1.0278E+00 9.8295E-01 9.3764E-01 8.9183E-01
8.5386E-01 8.3486E-01 8.3034E-01 8.0220E-01
6.9960E-01 5.6420E-01 4.5433E-01 3.7100E-01
3.1976E-01 2.6597E-01 2.1873E-01 1.9804E-01
1.7171E-01 1.4155E-01 1.1271E-01 8.7348E-02
6.9166E-02 6.1197E-02 3.3032E-02 2.8487E-03
3.5803E-04 4.6217E-05 5.0343E-06 3.6659E-07;
/H*(10) flux response [constant]
2.5601E+01 2.5110E+01 2.4123E+01 2.3123E+01
2.2111E+01 2.1601E+01 2.1359E+01 2.0874E+01
2.0384E+01 1.9890E+01 1.9390E+01 1.8886E+01
1.8375E+01 1.7861E+01 1.7601E+01 1.7343E+01

3.5803E-04 4.6217E-05 5.0343E-06 3.6659E-07
/repeat 244 groups for electrons/positrons

2.5601E+01 2.5110E+01 2.4123E+01 2.3123E+01
2.2111E+01 2.1601E+01 2.1359E+01 2.0874E+01
2.0384E+01 1.9890E+01 1.9390E+01 1.8886E+01
1.8375E+01 1.7861E+01 1.7601E+01 1.7343E+01
1.6825E+01 1.6459E+01 1.6142E+01 1.5716E+01
1.5501E+01 1.5193E+01 1.4679E+01 1.4365E+01
1.4047E+01 1.3618E+01 1.3401E+01 1.3290E+01
1.3069E+01 1.2789E+01 1.2449E+01 1.2085E+01
1.1695E+01 1.1300E+01 1.1101E+01 1.0904E+01
1.0506E+01 1.0101E+01 9.6860E+00 9.2589E+00
8.8226E+00 8.6014E+00 8.3927E+00 7.9748E+00
7.6105E+00 7.3531E+00 7.0765E+00 6.9018E+00
6.7379E+00 6.4685E+00 6.3529E+00 5.9511E+00
5.3806E+00 5.2018E+00 5.0994E+00 4.8971E+00
4.6922E+00 4.5370E+00 4.4341E+00 4.3817E+00
4.3339E+00 4.2184E+00 4.1140E+00 4.0441E+00
3.9623E+00 3.8919E+00 3.8448E+00 3.7858E+00
3.6790E+00 3.5719E+00 3.4895E+00 3.4414E+00
3.4337E+00 3.4211E+00 3.3641E+00 3.2500E+00
3.0595E+00 2.9313E+00 2.7930E+00 2.5191E+00
2.3811E+00 2.3366E+00 2.2499E+00 2.1775E+00
2.1196E+00 2.0543E+00 1.9818E+00 1.9091E+00
1.8373E+00 1.8009E+00 1.7550E+00 1.6800E+00
1.6050E+00 1.5300E+00 1.4250E+00 1.2756E+00
1.2006E+00 1.1844E+00 1.1533E+00 1.1222E+00
1.0911E+00 1.0601E+00 1.0368E+00 1.0213E+00
9.9811E-01 9.7490E-01 9.5018E-01 9.3010E-01
9.0897E-01 8.9046E-01 8.7616E-01 8.4846E-01
8.2764E-01 8.1374E-01 7.9285E-01 7.6494E-01
6.8077E-01 6.1028E-01 6.0807E-01 6.0422E-01
6.0035E-01 5.9646E-01 5.9256E-01 5.8864E-01
5.8471E-01 5.8076E-01 5.7680E-01 5.7282E-01
5.6681E-01 5.5875E-01 5.4878E-01 5.3794E-01
5.3168E-01 5.3017E-01 5.2888E-01 5.2712E-01
5.2331E-01 5.1782E-01 5.1278E-01 5.1003E-01
5.1453E-01 5.2389E-01 5.3176E-01 5.3690E-01
5.4225E-01 5.4764E-01 5.4989E-01 5.5575E-01
5.6550E-01 5.7577E-01 5.8642E-01 5.9419E-01
5.9873E-01 6.0128E-01 6.0362E-01 6.0574E-01
6.0813E-01 6.1053E-01 6.1296E-01 6.1542E-01
6.1790E-01 6.2040E-01 6.2293E-01 6.2548E-01
6.2806E-01 6.3199E-01 6.3709E-01 6.3978E-01
6.4165E-01 6.4496E-01 6.4831E-01 6.5170E-01
6.5513E-01 6.5860E-01 6.6211E-01 6.6567E-01
6.6926E-01 6.7290E-01 6.7658E-01 6.8031E-01
6.8409E-01 6.8791E-01 6.9178E-01 6.9582E-01
7.0140E-01 7.0942E-01 7.1605E-01 7.2028E-01
7.2675E-01 7.3556E-01 7.4304E-01 7.5233E-01
7.6346E-01 7.7329E-01 7.8341E-01 7.9383E-01
8.0422E-01 8.0967E-01 8.1217E-01 8.1656E-01
8.2100E-01 8.2550E-01 8.3053E-01 8.3516E-01
8.3988E-01 8.4465E-01 8.5049E-01 8.5791E-01
8.6396E-01 8.7439E-01 8.9037E-01 9.1956E-01
9.5720E-01 9.9190E-01 1.0297E+00 1.0497E+00
1.0278E+00 9.8295E-01 9.3764E-01 8.9183E-01
8.5386E-01 8.3486E-01 8.3034E-01 8.0220E-01
6.9960E-01 5.6420E-01 4.5433E-01 3.7100E-01
3.1976E-01 2.6597E-01 2.1873E-01 1.9804E-01
1.7171E-01 1.4155E-01 1.1271E-01 8.7348E-02
6.9166E-02 6.1197E-02 3.3032E-02 2.8487E-03
3.5803E-04 4.6217E-05 5.0343E-06 3.6659E-07;
/H*(10) flux response [constant]
2.5601E+01 2.5110E+01 2.4123E+01 2.3123E+01
2.2111E+01 2.1601E+01 2.1359E+01 2.0874E+01
2.0384E+01 1.9890E+01 1.9390E+01 1.8886E+01
1.8375E+01 1.7861E+01 1.7601E+01 1.7343E+01

PARTISN Sample input file (continued)

1.6825E+01 1.6459E+01 1.6142E+01 1.5716E+01
 1.5501E+01 1.5193E+01 1.4679E+01 1.4365E+01
 1.4047E+01 1.3618E+01 1.3401E+01 1.3290E+01
 1.3069E+01 1.2789E+01 1.2449E+01 1.2085E+01
 1.1695E+01 1.1300E+01 1.1101E+01 1.0904E+01
 1.0506E+01 1.0101E+01 9.6860E+00 9.2589E+00
 8.8226E+00 8.6014E+00 8.3927E+00 7.9748E+00
 7.6105E+00 7.3531E+00 7.0765E+00 6.9018E+00
 6.7379E+00 6.4685E+00 6.3529E+00 5.9511E+00
 5.3806E+00 5.2018E+00 5.0994E+00 4.8971E+00
 4.6922E+00 4.5370E+00 4.4341E+00 4.3817E+00
 4.3339E+00 4.2184E+00 4.1140E+00 4.0441E+00
 3.9623E+00 3.8919E+00 3.8448E+00 3.7858E+00
 3.6790E+00 3.5719E+00 3.4895E+00 3.4414E+00
 3.4337E+00 3.4211E+00 3.3641E+00 3.2500E+00
 3.0595E+00 2.9313E+00 2.7930E+00 2.5191E+00
 2.3811E+00 2.3366E+00 2.2499E+00 2.1775E+00
 2.1196E+00 2.0543E+00 1.9818E+00 1.9091E+00
 1.8373E+00 1.8009E+00 1.7550E+00 1.6800E+00
 1.6050E+00 1.5300E+00 1.4250E+00 1.2756E+00
 1.2006E+00 1.1844E+00 1.1533E+00 1.1222E+00
 1.0911E+00 1.0601E+00 1.0368E+00 1.0213E+00
 9.9811E-01 9.7490E-01 9.5018E-01 9.3010E-01
 9.0897E-01 8.9046E-01 8.7616E-01 8.4846E-01
 8.2764E-01 8.1374E-01 7.9285E-01 7.6494E-01
 6.8077E-01 6.1028E-01 6.0807E-01 6.0422E-01
 6.0035E-01 5.9646E-01 5.9256E-01 5.8864E-01
 5.8471E-01 5.8076E-01 5.7680E-01 5.7282E-01
 5.6681E-01 5.5875E-01 5.4878E-01 5.3794E-01
 5.3168E-01 5.3017E-01 5.2888E-01 5.2712E-01
 5.2331E-01 5.1782E-01 5.1278E-01 5.1003E-01
 5.1453E-01 5.2389E-01 5.3176E-01 5.3690E-01
 5.4225E-01 5.4764E-01 5.4989E-01 5.5575E-01
 5.6550E-01 5.7577E-01 5.8642E-01 5.9419E-01
 5.9873E-01 6.0128E-01 6.0362E-01 6.0574E-01
 6.0813E-01 6.1053E-01 6.1296E-01 6.1542E-01
 6.1790E-01 6.2040E-01 6.2293E-01 6.2548E-01
 6.2806E-01 6.3199E-01 6.3709E-01 6.3978E-01
 6.4165E-01 6.4496E-01 6.4831E-01 6.5170E-01
 6.5513E-01 6.5860E-01 6.6211E-01 6.6567E-01
 6.6926E-01 6.7290E-01 6.7658E-01 6.8031E-01
 6.8409E-01 6.8791E-01 6.9178E-01 6.9582E-01
 7.0140E-01 7.0942E-01 7.1605E-01 7.2028E-01
 7.2675E-01 7.3556E-01 7.4304E-01 7.5233E-01
 7.6346E-01 7.7329E-01 7.8341E-01 7.9383E-01
 8.0422E-01 8.0967E-01 8.1217E-01 8.1656E-01
 8.2100E-01 8.2550E-01 8.3053E-01 8.3516E-01
 8.3988E-01 8.4465E-01 8.5049E-01 8.5791E-01
 8.6396E-01 8.7439E-01 8.9037E-01 9.1956E-01
 9.5720E-01 9.9190E-01 1.0297E+00 1.0497E+00
 1.0278E+00 9.8295E-01 9.3764E-01 8.9183E-01
 8.5386E-01 8.3486E-01 8.3034E-01 8.0220E-01
 6.9960E-01 5.6420E-01 4.5433E-01 3.7100E-01
 3.1976E-01 2.6597E-01 2.1873E-01 1.9804E-01
 1.7171E-01 1.4155E-01 1.1271E-01 8.7348E-02
 6.9166E-02 6.1197E-02 6.1000E-02 6.1000E-02
 6.1000E-02 6.1000E-02 6.1000E-02 6.1000E-02
 / repeat 244 groups for electrons/positrons
 2.5601E+01 2.5110E+01 2.4123E+01 2.3123E+01
 2.2111E+01 2.1601E+01 2.1359E+01 2.0874E+01

2.0384E+01 1.9890E+01 1.9390E+01 1.8886E+01
 1.8375E+01 1.7861E+01 1.7601E+01 1.7343E+01
 1.6825E+01 1.6459E+01 1.6142E+01 1.5716E+01
 1.5501E+01 1.5193E+01 1.4679E+01 1.4365E+01
 1.4047E+01 1.3618E+01 1.3401E+01 1.3290E+01
 1.3069E+01 1.2789E+01 1.2449E+01 1.2085E+01
 1.1695E+01 1.1300E+01 1.1101E+01 1.0904E+01
 1.0506E+01 1.0101E+01 9.6860E+00 9.2589E+00
 8.8226E+00 8.6014E+00 8.3927E+00 7.9748E+00
 7.6105E+00 7.3531E+00 7.0765E+00 6.9018E+00
 6.7379E+00 6.4685E+00 6.3529E+00 5.9511E+00
 5.3806E+00 5.2018E+00 5.0994E+00 4.8971E+00
 4.6922E+00 4.5370E+00 4.4341E+00 4.3817E+00
 4.3339E+00 4.2184E+00 4.1140E+00 4.0441E+00
 3.9623E+00 3.8919E+00 3.8448E+00 3.7858E+00
 3.6790E+00 3.5719E+00 3.4895E+00 3.4414E+00
 3.4337E+00 3.4211E+00 3.3641E+00 3.2500E+00
 3.0595E+00 2.9313E+00 2.7930E+00 2.5191E+00
 2.3811E+00 2.3366E+00 2.2499E+00 2.1775E+00
 2.1196E+00 2.0543E+00 1.9818E+00 1.9091E+00
 1.8373E+00 1.8009E+00 1.7550E+00 1.6800E+00
 1.6050E+00 1.5300E+00 1.4250E+00 1.2756E+00
 1.2006E+00 1.1844E+00 1.1533E+00 1.1222E+00
 1.0911E+00 1.0601E+00 1.0368E+00 1.0213E+00
 9.9811E-01 9.7490E-01 9.5018E-01 9.3010E-01
 9.0897E-01 8.9046E-01 8.7616E-01 8.4846E-01
 8.2764E-01 8.1374E-01 7.9285E-01 7.6494E-01
 6.8077E-01 6.1028E-01 6.0807E-01 6.0422E-01
 6.0035E-01 5.9646E-01 5.9256E-01 5.8864E-01
 5.8471E-01 5.8076E-01 5.7680E-01 5.7282E-01
 5.6681E-01 5.5875E-01 5.4878E-01 5.3794E-01
 5.3168E-01 5.3017E-01 5.2888E-01 5.2712E-01
 5.2331E-01 5.1782E-01 5.1278E-01 5.1003E-01
 5.1453E-01 5.2389E-01 5.3176E-01 5.3690E-01
 5.4225E-01 5.4764E-01 5.4989E-01 5.5575E-01
 5.6550E-01 5.7577E-01 5.8642E-01 5.9419E-01
 5.9873E-01 6.0128E-01 6.0362E-01 6.0574E-01
 6.0813E-01 6.1053E-01 6.1296E-01 6.1542E-01
 6.1790E-01 6.2040E-01 6.2293E-01 6.2548E-01
 6.2806E-01 6.3199E-01 6.3709E-01 6.3978E-01
 6.4165E-01 6.4496E-01 6.4831E-01 6.5170E-01
 6.5513E-01 6.5860E-01 6.6211E-01 6.6567E-01
 6.6926E-01 6.7290E-01 6.7658E-01 6.8031E-01
 6.8409E-01 6.8791E-01 6.9178E-01 6.9582E-01
 7.0140E-01 7.0942E-01 7.1605E-01 7.2028E-01
 7.2675E-01 7.3556E-01 7.4304E-01 7.5233E-01
 7.6346E-01 7.7329E-01 7.8341E-01 7.9383E-01
 8.0422E-01 8.0967E-01 8.1217E-01 8.1656E-01
 8.2100E-01 8.2550E-01 8.3053E-01 8.3516E-01
 8.3988E-01 8.4465E-01 8.5049E-01 8.5791E-01
 8.6396E-01 8.7439E-01 8.9037E-01 9.1956E-01
 9.5720E-01 9.9190E-01 1.0297E+00 1.0497E+00
 1.0278E+00 9.8295E-01 9.3764E-01 8.9183E-01
 8.5386E-01 8.3486E-01 8.3034E-01 8.0220E-01
 6.9960E-01 5.6420E-01 4.5433E-01 3.7100E-01
 3.1976E-01 2.6597E-01 2.1873E-01 1.9804E-01
 1.7171E-01 1.4155E-01 1.1271E-01 8.7348E-02
 6.9166E-02 6.1197E-02 6.1000E-02 6.1000E-02
 6.1000E-02 6.1000E-02 6.1000E-02 6.1000E-02;
 /
 ppoints=1,700,701,900
 t

Appendix 13: Anatomy of PARTISN Input Parameters

This appendix documents my choices for relevant input parameter in PARTISN.

```

/***** BLOCK 1 *****/
igeom=1                               Slab Geometry

ngroup=488                             488 Energy Groups, 244 photon, 244 electron

isn= 50                                # of quadrature directions, 50 because S100 has 50
                                        symetric, negative directions

niso= 2                                Since we formatted cross sections, we can treat each
                                        material as an isotope

mt= 2                                   two materials (each comprised of a single isotope
                                        defined by niso)

nzone=2                                # of geometric zones

im=2                                    coarse mesh intervals

it= 900                                total number of fine mesh intervals

idimen=1                               # of geometric dimensions

maxlcm=4000000                         length of large core memory

maxscm= 5000000                        length of small core memory

iquad= 3                                type of quadrature, 3 means user defined

nn=1                                    # of levels per octant

/***** BLOCK 2 *****/
xmesh=0.0; 2.38879 2.42077             coordinates of coarse mesh edges in x-direction

xints= 700 200                          divides coarse mesh interval into a given # of fine mesh
                                        intervals

zones=1 2                                Zone number for each mesh ( 0 indicates a void mesh)

```

```

/***** BLOCK 3 *****/
lib= bxslib          name and form of cross section library

maxord= 7           highest legendre order in scattering tables

ihm=981             # of positions in each row of the cross section table

iht= 6              position number of the total cross section

ihs= 494            position of the self scatter cross section

ifido=0             Format of Cross section library

ititl=1             A title line precedes each table

i2lp1=0             Higher order scattering cross sections on the library
                    contain the 2L+1 Term

edname=char secp ener  Cross section name for each of the edit cross section
                    positions used in the cross section edits. Theses are the
                    positions before the absorption cross sections in the
                    table.

ebound=             Energy group boundaries. (here the group boundaries
                    are listed)

```

```

/***** BLOCK 4 *****/
matls=isos          Instructions for mixing isotopes

assign= 1 1 1.0; 2 2 1.0;  assignment of materials to geometric zones.

```

```

/***** BLOCK 5 *****/
mu =                quadrature details

wgt=                quadrature weights

ievt= 0             calculation type

isct= 7             legendre scattering order

ith=0              direct/adjoint calculation

ibl=0              left boundary conditions

```

ibr=0	right boundary conditions
epsi=1.e-4	convergence precision
iitl=100	max number of inner iterations per group
nll=50	number of angles per level for general quadrature
saleft= 116y1; 1,49r0; 50r0; 369y1;	(Source Term) The following commands write 50r0; "1" in the appropriate column for a given energy group
norm=1	normalize the inhomogeneous source rate when IEVT=0
sourcp=3	Prints the source term
xsctp=1	Prints the cross sections
/***** BLOCK 6 *****/	
pted=1	Do edits by fine mesh
icoll= 244,244	Breaks the 488 groups into 2 broad groups in this case each of length 244.
igrped= 3	Choosing "3" here prints the response and flux in each broad group in addition to their sum.
rsfnam= flux, airExp, Dose_e, Dose_c	Character names of user defined response functions
rsfe	response function energy distribution for each of the desired response function.

Appendix 14: Sample MCNP5 input file for 65 keV photons incident on a 2 mfp shield of aluminum followed by lead

```

65 keV 1 mfp Al 1mfp Pb at normal Al/Lead
c
c
c 1 mfp al slab, 1 mfp lead slab normal photon beam at 65 keV
c flux tally for comparison with SN method
c energy bin structure mirrors 244 groups of the SN calculation
c mcplib04 is used, consistent with the xsects used for SN
c
c CELL
1 2 -11.35 -1 2 -3 4 -5 6 imp:p=3 $ pb
2 1 -2.70 -1 2 -3 4 -6 8 imp:p=1 $ al
3 2 -11.35 -1 2 -3 4 5 -7 imp:p=9 $ pb
4 0 #1 #2 #3 imp:p=0 $ outside slab

c SURFACE
*1 px 1.0 $ x max -refl
*2 px -1.0 $ x min -refl
*3 py 1.0 $ y max -refl
*4 py -1.0 $ y min -refl
5 pz 1.5703 $ z max - 1 mfp lead/W
6 pz 1.54654 $ slab split b/w z max & min
7 pz 1.57045 $ z min
8 pz 0.0 $ z min

c DATA
nps 2000000
c cut:p 1.01 $ time cutoff= 1shake, low E cutoff at 10keV
print
mode p
m1 13000 -1.0 plib=04p
m2 82000 -1.0 plib=04p
c ext:p s 0 $ exponential transform in slab pg. 3-37 MCNP4C manual
c
c SOURCE
sdef x=d1 y=d2 z=0.0 vec=0 0 1.0
dir=1 erg=d3
si1 -1.0 1.0
sp1 0 1
si2 -1.0 1.0
sp2 0 1
si3 .065 .069525
sp3 0 1
c
c TALLIES
e0 1.71290E-03 2.55620E-03 3.58820E-03 4.91880E-03 &
6.79410E-03 1.00000E-02 1.01000E-02 1.03670E-02 &
1.07600E-02 1.12150E-02 1.15630E-02 1.19100E-02 &
1.20990E-02 1.22830E-02 1.28240E-02 1.30400E-02 &
1.34180E-02 1.38790E-02 1.43520E-02 1.48390E-02 &
1.50000E-02 1.51000E-02 1.52000E-02 1.58600E-02 &
1.69000E-02 1.79300E-02 1.89700E-02 2.00000E-02 &
2.01000E-02 2.12500E-02 2.25000E-02 2.37500E-02 &
2.55140E-02 2.62500E-02 2.70000E-02 2.72500E-02 &
2.76000E-02 2.80000E-02 2.82000E-02 2.85000E-02 &
2.87000E-02 2.90000E-02 2.92500E-02 2.95000E-02 &
2.97500E-02 3.00000E-02 3.01000E-02 3.05000E-02 &
3.10000E-02 3.15000E-02 3.20000E-02 3.25000E-02 &
3.31690E-02 3.35000E-02 3.40000E-02 3.45000E-02 &
3.47500E-02 3.50000E-02 3.55500E-02 3.59840E-02 &
3.62500E-02 3.65000E-02 3.67500E-02 3.70000E-02 &
3.72500E-02 3.75000E-02 3.77500E-02 3.80000E-02 &
3.82500E-02 3.85000E-02 3.87500E-02 3.90000E-02 &
3.92500E-02 3.95000E-02 3.97500E-02 4.00000E-02 &

```

MCNP5 Sample continued:

4.01000E-02 4.05000E-02 4.10000E-02 4.12500E-02 &
 4.15000E-02 4.17500E-02 4.20000E-02 4.22500E-02 &
 4.25000E-02 4.27500E-02 4.30000E-02 4.32500E-02 &
 4.35000E-02 4.37000E-02 4.40000E-02 4.42500E-02 &
 4.50000E-02 4.60000E-02 4.75000E-02 4.85000E-02 &
 5.00000E-02 5.01000E-02 5.10000E-02 5.25000E-02 &
 5.35000E-02 5.50000E-02 5.75000E-02 6.00000E-02 &
 6.01000E-02 6.50000E-02 6.95250E-02 7.61110E-02 &
 7.75000E-02 8.00000E-02 8.01000E-02 8.07240E-02 &
 8.31020E-02 8.60000E-02 8.80000E-02 9.00000E-02 &
 9.10000E-02 9.20000E-02 9.30000E-02 9.40000E-02 &
 9.50000E-02 9.60000E-02 9.70000E-02 9.80000E-02 &
 9.90000E-02 1.00000E-01 1.01000E-01 1.25000E-01 &
 1.30000E-01 1.35000E-01 1.37500E-01 1.40000E-01 &
 1.45000E-01 1.50000E-01 1.51000E-01 1.56000E-01 &
 1.57000E-01 1.62500E-01 1.65000E-01 1.70000E-01 &
 1.72500E-01 1.75000E-01 1.80000E-01 1.85000E-01 &
 1.90000E-01 1.95000E-01 2.00000E-01 2.01000E-01 &
 2.25000E-01 2.50000E-01 2.60000E-01 2.75000E-01 &
 2.85000E-01 3.00000E-01 3.01000E-01 3.12500E-01 &
 3.25000E-01 3.37500E-01 3.50000E-01 3.60000E-01 &
 3.70000E-01 3.85000E-01 4.00000E-01 4.01000E-01 &
 4.50000E-01 5.00000E-01 5.01000E-01 5.50000E-01 &
 5.75000E-01 5.95000E-01 5.97500E-01 6.00000E-01 &
 6.01000E-01 6.20000E-01 6.35000E-01 6.65000E-01 &
 6.80000E-01 6.90000E-01 7.00000E-01 7.20000E-01 &
 7.35000E-01 7.50000E-01 7.80000E-01 8.00000E-01 &
 8.01000E-01 8.25000E-01 8.50000E-01 9.00000E-01 &
 9.50000E-01 1.00000E+00 1.00100E+00 1.10000E+00 &
 1.33000E+00 1.33500E+00 1.40000E+00 1.50000E+00 &
 1.50100E+00 1.60000E+00 1.66000E+00 1.75000E+00 &
 1.87500E+00 2.00000E+00 2.00100E+00 2.16600E+00 &
 2.33300E+00 2.50000E+00 2.66600E+00 2.83300E+00 &
 3.00000E+00 3.00100E+00 3.16600E+00 3.33300E+00 &
 3.50000E+00 3.65000E+00 3.80000E+00 3.90000E+00 &
 4.00000E+00 4.00100E+00 4.20000E+00 4.40000E+00 &
 4.50000E+00 4.70000E+00 5.00000E+00 5.00100E+00 &
 5.20000E+00 5.40000E+00 5.50000E+00 5.75000E+00 &
 6.00000E+00 6.00100E+00 6.25000E+00 6.50000E+00 &
 6.75000E+00 7.00000E+00 7.25000E+00 7.50000E+00 &
 7.75000E+00 8.00000E+00 8.00100E+00 8.50000E+00 &
 9.00000E+00 9.50000E+00 1.00000E+01 1.00010E+01
 c
 fc12 Transmitted Flux midmesh surface (1/cm²-photon)
 fl2:p 5
 fm12 4.0 \$ multiply by 4 to get normalized flux
 c
 fc22 Transmitted Flux middle surface(1/cm²-photon)
 f22:p 6
 fm22 4.0 \$ multiply by 4 to get normalized flux
 c
 fc32 Transmitted Flux Far Surface (1/cm²-photon)
 f32:p 7
 fm32 4.0 \$ multiply by 4 to get normalized flux
 c
 fc14 Track Length Estimator midmesh surface
 fl4:p 3
 fm14 4.0 \$ multiply by 4 to get normalized flux
 c
 fc42 Transmitted H*(10) [Extrapolation] (Sv/cm²-photon)
 f42:p 5
 ft42 inc \$ identify particles by collision (page 3-106)
 fu42 0 1 10 \$ discriminate particles by collisions (page 3-90)
 fq42 e u \$ tabulate by energy (y) & collisions (x) (page 3-87)
 fm42 4.0 \$ multiply by 4 to get flux (1/cm²) (page 3-88)
 de42 1.00000e-002 1.50000e-002 2.00000e-002 3.00000e-002 &
 4.00000e-002 5.00000e-002 6.00000e-002 8.00000e-002 &

MCNP5 Sample continued:

1.00000e-001 1.50000e-001 2.00000e-001 3.00000e-001 &
 4.00000e-001 5.00000e-001 6.00000e-001 8.00000e-001 &
 1.00000e+00 1.50000e+000 2.00000e+000 3.00000e+00 &
 4.00000e+00 5.00000e+000 6.00000e+000 8.00000e+00 &
 1.00000e+001
 c
 df42 6.10000e-002 8.30000e-001 1.05000e+000 8.10000e-001 &
 6.40000e-001 5.50000e-001 5.10000e-001 5.30000e-001 &
 6.10000e-001 8.90000e-001 1.20000e+00 1.80000e+000 &
 2.38000e+000 2.93000e+000 3.44000e+000 4.38000e+000 &
 5.20000e+000 6.90000e+000 8.60000e+000 1.11000e+001 &
 1.34000e+001 1.55000e+001 1.76000e+001 2.16000e+001 &
 2.56000e+001
 c
 fc52 Transmitted Exposure (exposure units)
 *f52:p 5
 ft52 inc \$ identify particles by collision (page 3-106)
 fu52 0 1 10 \$ discriminate particles by collisions (page 3-99)
 fq52 e u \$ tabulate by energy (y) & collisions (x) (page 3-87)
 fm52 4.0 \$ multiply by 4 to get flux (1/cm^2) (page 3-88)
 c (mu_en)/rho from XCOM:Photon Cross Section Database
 c the star (*f31) tally multiplies flux by E for Exposure tally
 c Exposure = Constant*E*(mu_en/rho)*flux(E)
 de52 1.00000e-003 1.50000e-003 2.00000e-003 3.00000e-003 &
 3.20290e-003 4.00000e-003 5.00000e-003 6.00000e-003 &
 8.00000e-003 1.00000e-002 1.50000e-002 2.00000e-002 &
 3.00000e-002 4.00000e-002 5.00000e-002 6.00000e-002 &
 8.00000e-002 1.00000e-001 1.50000e-001 2.00000e-001 &
 3.00000e-001 4.00000e-001 5.00000e-001 6.00000e-001 &
 8.00000e-001 1.00000e+000 1.25000e+000 1.50000e+000 &
 2.00000e+000 3.00000e+000 4.00000e+000 5.00000e+000 &
 6.00000e+000 8.00000e+000 1.00000e+001 1.50000e+001
 c
 df52 3.59900e+003 1.18800e+003 5.26200e+002 1.61400e+002 &
 1.46000e+002 7.63600e+001 3.93100e+001 2.27000e+001 &
 9.44600e+000 4.74200e+000 1.33400e+000 5.38900e-001 &
 1.53700e-001 6.83300e-002 4.09800e-002 3.04100e-002 &
 2.40700e-002 2.32500e-002 2.49600e-002 2.67200e-002 &
 2.87200e-002 2.94900e-002 2.96600e-002 2.95300e-002 &
 2.88200e-002 2.78900e-002 2.66600e-002 2.54700e-002 &
 2.34500e-002 2.05700e-002 1.87000e-002 1.74000e-002 &
 1.64700e-002 1.52500e-002 1.45000e-002 1.35300e-002

Appendix 15: Sample MCNP5 input file illustrating the variance reduction technique used for 65 keV photons incident on a 10 mfp shield of aluminum followed by lead

```

65 keV on 5 mfp Al followed by 5 mfp of Pb
c
c 5mfp al slab, 5mfp lead slab normal photon beam at 1 MeV
c flux tally for comparison with SN method
c energy bin structure mirrors 244 groups of the SN calculatio
c mcplib04 is used, consistent with the xssects used for SN
c
c CELL
1 1 -2.70 -1 2 -3 4 16 -5 imp:p=1
2 1 -2.70 -1 2 -3 4 5 -6 imp:p=3
3 1 -2.70 -1 2 -3 4 6 -7 imp:p=9
4 1 -2.70 -1 2 -3 4 7 -8 imp:p=27
5 1 -2.70 -1 2 -3 4 8 -9 imp:p=81
6 2 -11.35 -1 2 -3 4 9 -10 imp:p=243
7 2 -11.35 -1 2 -3 4 10 -11 imp:p=729
8 2 -11.35 -1 2 -3 4 11 -12 imp:p=2187
9 2 -11.35 -1 2 -3 4 12 -13 imp:p=6561
10 2 -11.35 -1 2 -3 4 13 -14 imp:p=19683
11 2 -11.35 -1 2 -3 4 14 -15 imp:p=59049
12 0 #1 #2 #3 #4 #5 #6 #7 #8 #9 #10 #11 imp:p=0

c SURFACE
*1 px 1.0 $ x max -refl
*2 px -1.0 $ x min -refl
*3 py 1.0 $ y max -refl
*4 py -1.0 $ y min -refl
5 pz 1.546544
6 pz 3.093088
7 pz 4.6396324
8 pz 6.186176
9 pz 7.73272
10 pz 7.75663
11 pz 7.78054
12 pz 7.80445
13 pz 7.82836
14 pz 7.8522
15 pz 7.85227
16 pz 0.0 $ z min

c DATA
c
nps 2000000
c cut:p 1 .01 wc2=.25 $ time cutoff = 1shake, low E cutoff at 10keV
print
mode p
m1 13000 -1.0 plib=04p
m2 82000 -1.0 plib=04p
c ext:p s 0 $ exponential transform in slab pg. 3-37 MCNP4C ma
c
c SOURCE
c
sdef x=d1 y=d2 z=0.0 vec=0 0 1.0
dir=1 erg=.0672625
si1 -1.0 1.0
sp1 0 1
si2 -1.0 1.0
sp2 0 1
c
c TALLIES
e0 1.71290E-03 2.55620E-03 3.58820E-03 4.91880E-03 &
6.79410E-03 1.00000E-02 1.01000E-02 1.03670E-02 &
MCNP Sample (Variance Reduction) continued:
1.07600E-02 1.12150E-02 1.15630E-02 1.19100E-02 &

```

1.20990E-02 1.22830E-02 1.28240E-02 1.30400E-02 &
 1.34180E-02 1.38790E-02 1.43520E-02 1.48390E-02 &
 1.50000E-02 1.51000E-02 1.52000E-02 1.58600E-02 &
 1.69000E-02 1.79300E-02 1.89700E-02 2.00000E-02 &
 2.01000E-02 2.12500E-02 2.25000E-02 2.37500E-02 &
 2.55140E-02 2.62500E-02 2.70000E-02 2.72500E-02 &
 2.76000E-02 2.80000E-02 2.82000E-02 2.85000E-02 &
 2.87000E-02 2.90000E-02 2.92500E-02 2.95000E-02 &
 2.97500E-02 3.00000E-02 3.01000E-02 3.05000E-02 &
 3.10000E-02 3.15000E-02 3.20000E-02 3.25000E-02 &
 3.31690E-02 3.35000E-02 3.40000E-02 3.45000E-02 &
 3.47500E-02 3.50000E-02 3.55500E-02 3.59840E-02 &
 3.62500E-02 3.65000E-02 3.67500E-02 3.70000E-02 &
 3.72500E-02 3.75000E-02 3.77500E-02 3.80000E-02 &
 3.82500E-02 3.85000E-02 3.87500E-02 3.90000E-02 &
 3.92500E-02 3.95000E-02 3.97500E-02 4.00000E-02 &
 4.01000E-02 4.05000E-02 4.10000E-02 4.12500E-02 &
 4.15000E-02 4.17500E-02 4.20000E-02 4.22500E-02 &
 4.25000E-02 4.27500E-02 4.30000E-02 4.32500E-02 &
 4.35000E-02 4.37000E-02 4.40000E-02 4.42500E-02 &
 4.50000E-02 4.60000E-02 4.75000E-02 4.85000E-02 &
 5.00000E-02 5.01000E-02 5.10000E-02 5.25000E-02 &
 5.35000E-02 5.50000E-02 5.75000E-02 6.00000E-02 &
 6.01000E-02 6.50000E-02 6.95250E-02 7.61110E-02 &
 7.75000E-02 8.00000E-02 8.01000E-02 8.07240E-02 &
 8.31020E-02 8.60000E-02 8.80000E-02 9.00000E-02 &
 9.10000E-02 9.20000E-02 9.30000E-02 9.40000E-02 &
 9.50000E-02 9.60000E-02 9.70000E-02 9.80000E-02 &
 9.90000E-02 1.00000E-01 1.01000E-01 1.25000E-01 &
 1.30000E-01 1.35000E-01 1.37500E-01 1.40000E-01 &
 1.45000E-01 1.50000E-01 1.51000E-01 1.56000E-01 &
 1.57000E-01 1.62500E-01 1.65000E-01 1.70000E-01 &
 1.72500E-01 1.75000E-01 1.80000E-01 1.85000E-01 &
 1.90000E-01 1.95000E-01 2.00000E-01 2.01000E-01 &
 2.25000E-01 2.50000E-01 2.60000E-01 2.75000E-01 &
 2.85000E-01 3.00000E-01 3.01000E-01 3.12500E-01 &
 3.25000E-01 3.37500E-01 3.50000E-01 3.60000E-01 &
 3.70000E-01 3.85000E-01 4.00000E-01 4.01000E-01 &
 4.50000E-01 5.00000E-01 5.01000E-01 5.50000E-01 &
 5.75000E-01 5.95000E-01 5.97500E-01 6.00000E-01 &
 6.01000E-01 6.20000E-01 6.35000E-01 6.65000E-01 &
 6.80000E-01 6.90000E-01 7.00000E-01 7.20000E-01 &
 7.35000E-01 7.50000E-01 7.80000E-01 8.00000E-01 &
 8.01000E-01 8.25000E-01 8.50000E-01 9.00000E-01 &
 9.50000E-01 1.00000E+00 1.00100E+00 1.10000E+00 &
 1.33000E+00 1.33500E+00 1.40000E+00 1.50000E+00 &
 1.50100E+00 1.60000E+00 1.66000E+00 1.75000E+00 &
 1.87500E+00 2.00000E+00 2.00100E+00 2.16600E+00 &
 2.33300E+00 2.50000E+00 2.66600E+00 2.83300E+00 &
 3.00000E+00 3.00100E+00 3.16600E+00 3.33300E+00 &
 3.50000E+00 3.65000E+00 3.80000E+00 3.90000E+00 &
 4.00000E+00 4.00100E+00 4.20000E+00 4.40000E+00 &
 4.50000E+00 4.70000E+00 5.00000E+00 5.00100E+00 &
 5.20000E+00 5.40000E+00 5.50000E+00 5.75000E+00 &
 6.00000E+00 6.00100E+00 6.25000E+00 6.50000E+00 &
 6.75000E+00 7.00000E+00 7.25000E+00 7.50000E+00 &
 7.75000E+00 8.00000E+00 8.00100E+00 8.50000E+00 &
 9.00000E+00 9.50000E+00 1.00000E+01 1.00010E+01

c
 fc12 Transmitted Flux midmesh surface (1/cm²-photon)
 f12:p 14
 fm12 4.0 \$ multiply by 4 to get normalized flux

c
 fc22 Transmitted Flux middle surface(1/cm²-photon)
 f22:p 9

MCNP Sample (Variance Reduction) continued:

fm22 4.0 \$ multiply by 4 to get normalized flux

c
fc32 Transmitted Flux Far Surface (1/cm²-photon)
f32:p 15
fm32 4.0 \$ multiply by 4 to get normalized flux
c
fc14 Track Length Estimator midmesh surface
f14:p 11
fm14 4.0 \$ multiply by 4 to get normalized flux
c
fc42 Transmitted H*(10) [Extrapolation] (Sv/cm²-photon)
f42:p 14
ft42 inc \$ identify particles by collision (page 3-106)
fu42 0 1 10 \$ discriminate particles by collisions (page 3-90)
fq42 e u \$ tabulate by energy (y) & collisions (x) (page 3-87)
fm42 4.0 \$ multiply by 4 to get flux (1/cm²) (page 3-88)
de42 1.00000e-002 1.50000e-002 2.00000e-002 3.00000e-002 &
4.00000e-002 5.00000e-002 6.00000e-002 8.00000e-002 &
1.00000e-001 1.50000e-001 2.00000e-001 3.00000e-001 &
4.00000e-001 5.00000e-001 6.00000e-001 8.00000e-001 &
1.00000e+00 1.50000e+000 2.00000e+000 3.00000e+00 &
4.00000e+00 5.00000e+000 6.00000e+000 8.00000e+00 &
1.00000e+001
c
df42 6.10000e-002 8.30000e-001 1.05000e+000 8.10000e-001 &
6.40000e-001 5.50000e-001 5.10000e-001 5.30000e-001 &
6.10000e-001 8.90000e-001 1.20000e+00 1.80000e+000 &
2.38000e+000 2.93000e+000 3.44000e+000 4.38000e+000 &
5.20000e+000 6.90000e+000 8.60000e+000 1.11000e+001 &
1.34000e+001 1.55000e+001 1.76000e+001 2.16000e+001 &
2.56000e+001
c
fc52 Transmitted Exposure (exposure units)
*f52:p 14
ft52 inc \$ identify particles by collision (page 3-106)
fu52 0 1 10 \$ discriminate particles by collisions (page 3-99)
fq52 e u \$ tabulate by energy (y) & collisions (x) (page 3-87)
fm52 4.0 \$ multiply by 4 to get flux (1/cm²) (page 3-88)
c (mu_en)/rho from XCOM:Photon Cross Section Database
c the star (*f31) tally multiplies flux by E for Exposure tally
c Exposure = Constant*E*(mu_en/rho)*flux(E)
de52 1.00000e-003 1.50000e-003 2.00000e-003 3.00000e-003 &
3.20290e-003 4.00000e-003 5.00000e-003 6.00000e-003 &
8.00000e-003 1.00000e-002 1.50000e-002 2.00000e-002 &
3.00000e-002 4.00000e-002 5.00000e-002 6.00000e-002 &
8.00000e-002 1.00000e-001 1.50000e-001 2.00000e-001 &
3.00000e-001 4.00000e-001 5.00000e-001 6.00000e-001 &
8.00000e-001 1.00000e+000 1.25000e+000 1.50000e+000 &
2.00000e+000 3.00000e+000 4.00000e+000 5.00000e+000 &
6.00000e+000 8.00000e+000 1.00000e+001 1.50000e+001
c
df52 3.59900e+003 1.18800e+003 5.26200e+002 1.61400e+002 &
1.46000e+002 7.63600e+001 3.93100e+001 2.27000e+001 &
9.44600e+000 4.74200e+000 1.33400e+000 5.38900e-001 &
1.53700e-001 6.83300e-002 4.09800e-002 3.04100e-002 &
2.40700e-002 2.32500e-002 2.49600e-002 2.67200e-002 &
2.87200e-002 2.94900e-002 2.96600e-002 2.95300e-002 &
2.88200e-002 2.78900e-002 2.66600e-002 2.54700e-002 &
2.34500e-002 2.05700e-002 1.87000e-002 1.74000e-002 &
1.64700e-002 1.52500e-002 1.45000e-002 1.35300e-002